

SEALS SELECTION GUIDE

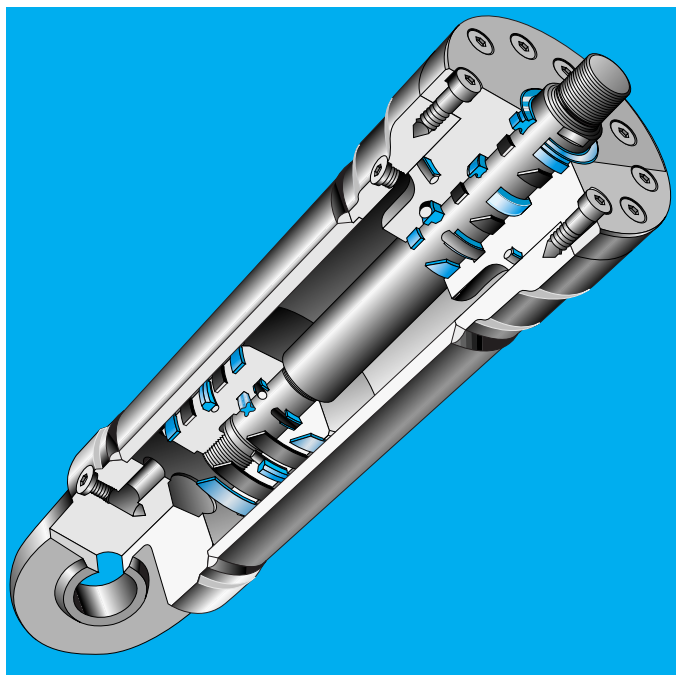



克普典科技股份有限公司
Captain Science Corporation

www.capind.com.tw

聯絡方式

citb@ms11.hinet.net

Line ID : @vsh6593b



北區

地址：10057台北市中正區信義路二段61號2樓

電話：(02) 2351-7107 轉 16 或 1

傳真：(02) 2396-4950

中、南區

地址：台中市神岡區中山路667巷26弄18號

電話：(04) 2561-0236 轉 11 或 18

傳真：(04) 2561-0010



Seals Selection Guide

Contents

Corporate Profile	1
Materials Selection Guide	2
Product Range Summary	4
Application Examples	13
Piston Seals:	
Turcon® Glyd Ring® T	22
D-A-S Compact Seal.....	27
Turcon® CST™ Seal.....	30
Rod Seals:	
U-Cup	34
Zurcon® B+S U-Cup	37
Turcon® Stepseal® K	42
Glyd Ring® HPR	48
Wipers:	
DA 17.....	51
DA 22	53
Turcon® Excluder ® 2.....	57
Turcon® Excluder ® 5.....	63
Rotary Seals:	
V-Seal	67
X-Sel® QUAD-RING® Seal	74
Turcon® Roto Glyd Ring®	80
Turcon® Roto Variseal™.....	92
Special Seals:	
Turcon® Variseal™ M2	98
Basic Seals:	
O-Ring	104
Back-Up Ring	142
QUAD-RING® Seal	149
Bearings:	
Turcite® Slydring®	160
Luytex® Wear Ring.....	160
Installation Instructions	164
Quality/Storage Criteria	166
Conversion Tables	168
Engineering Action Request	169

The information in this brochure is based on many decades of experience in the manufacture and application of sealing and bearing systems. However, unknown parameters and conditions may restrict general statements during usage. It is vital that customers satisfy themselves as to the suitability of individual products through adequate testing. For this reason, and due to the wide range of applications of our products, Busak+Shamban can accept no liability as to the suitability or correctness of our recommendations in individual cases.

The application limits for pressure, temperature and speed given in this catalog are maximum values determined in the laboratory. During practical applications, it should be remembered that due to the interaction of the operating parameters, the maximum values must be set correspondingly lower. For exceptional operating conditions, please contact us.

©Busak+Shamban, all rights reserved. The turquoise color is a registered trademark of the Busak+Shamban Group. This brochure, or any part thereof, may not be reproduced without our permission.



Corporate profile

Busak+Shamban is a worldwide manufacturer and supplier of quality sealing and bearing systems. Beginning in the 1950s, the Busak+Shamban Group of companies grew up together as separate, but intertwined companies. The Busak entity was founded in 1954 under the name Busak+Luyken. Beginning as a supplier of O-Rings, Busak+Luyken expanded its ability to deliver precision seals worldwide by developing close relationships with quality seal manufacturers. One of the primary manufacturers Busak+Luyken routinely teamed with was W.S. Shamban & Company.

W.S. Shamban & Company began manufacturing nonmetallic aerospace parts of PTFE in 1952. Since then, the company has established itself as a leader in technological advances of proprietary materials and innovative application engineering for both seals and bearings.

In 1992 these two successful establishments merged to form the Busak+Shamban Group®. Today you will find Busak+Shamban Manufacturing Facilities in three continents and over 40 Busak+Shamban Marketing Companies worldwide. In 1999, Busak+Shamban merged with Forsheda/Dowty and also joined the Smiths Group, a UK listed corporation, focusing high-tech niche markets on a global basis.

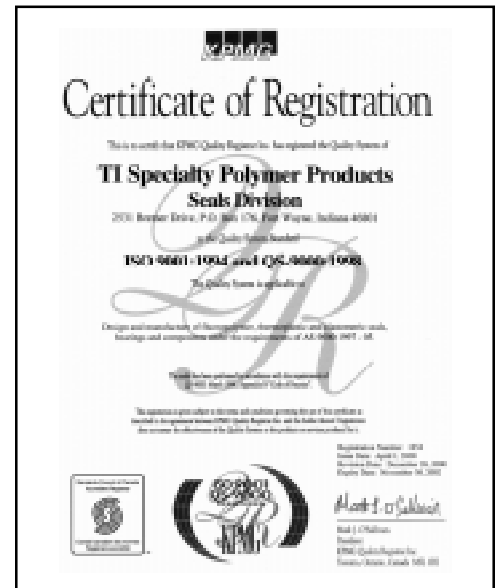
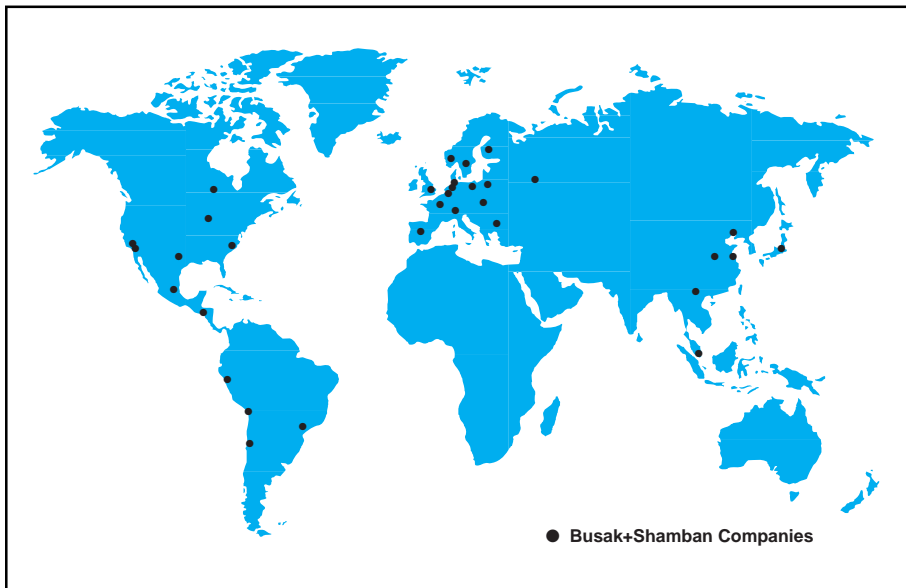

Global supply with local support

Modern, efficient and centralized logistics centers throughout Europe, Asia and America are responsible for managing high volume product inventories with an emphasis on quality control. All products must meet worldclass ISO compliance standards and certification program requirements. Busak+Shamban Marketing Companies and Appointed Distributors can pull from this centralized stock in addition to their own local inventory to ensure the best possible service.

The Logistics Center Europe, located in Germany and Logisitic Center Asia are an ISO 9002 approved logistics center along with all of our manufacturing units. Equipped with an electronic system which codes and tracks orders along a computer controlled conveyor system, this center provides ultramodern routing of orders through a stocking warehouse where orders are filled and shipped.

Our goal is to be an effective one-stop seal source. System-engineering is central to our sealing philosophy. Strategically positioned around the world, Busak+Shamban maintains staffs of experienced sales engineers, application engineers and Customer support personnel. Ongoing training and continuous improvement programs support our uncompromising Customer service. Careful inventory management ensures the best product availability, pricing and delivery for complete satisfaction.



























Materials Selection Guide

Table 1 Material Application Properties and Mating Surface Materials

Material Code and Application Properties	Temperature Range
Luytex® C380 Standard bearing material for high side load applications in hydraulic presses, mobile equipment, machine tools; high dynamic compressive strength, high wear resistance.	-60° C to +130° C (-76° F to 266° F)
Nitrile NCRO Standard material for KDAS seal used for machine processes, fork lift, agricultural machines; Shore A70.	-30° C to +110° C (-22° F to 230° F)
Nitrile N9 Standard Shore A90 material for DA17 wiper used in machine presses, machine tools and similar equipment.	-30° C to +110° C (-22° F to 230° F)
Polyurethane WUAQ3 Standard material for RU3 U-Cup and DA22 metric wiper; used for mobile hydraulics; high abrasion resistance.	-30° C to +100° C (-22° F to 212° F)
Turcite® T47 Used in mobile hydraulics, injection molding machines, presses etc.; low friction and very high wear resistance; capability to absorb debris.	-60° C to +200° C (-76° F to 392° F)
Turcon® T29 Standard seal material for Turcon® Glyd Ring® HPR, typically used for high speed, short stroke, and high pressure reciprocating motion.	-54° C to +200° C (-65° F to 392° F)
Turcon® T40 Standard seal material for rotary applications, mobile hydraulics, and machine tools.	-54° C to +200° C (-65° F to 392° F)
Turcon® T46 Standard seal material for reciprocating applications high compressive strength, good sliding and wear properties, resistance to gap extrusion.	-54° C to +200° C (-65° F to 392° F)
Zurcon® Z51 72 Shore D high performance polyurethane for seals and wipers used in mobile hydraulics and machine tools, high abrasion resistance.	-40° C to +110° C (-40° F to 230° F)
Zurcon® Z60/Himod® 60 Standard material for B+S back-up rings. High modulus for excellent extrusion resistance.	-54° C to +120° C (-65° F to 250° F)
Zurcon® Z94 Standard material for B+S U-Cup and DA22 imperial wiper; used in mobile, forestry and mining equipment; low hardness and good leakage control.	-40° C to +100° C (-40° F to 212° F)

Materials Selection Guide























































Compatible Fluids	Mating Surface Material	Available Products		
Mineral oil based hydraulic fluid, water	Steel, chrome plated steel, HRC \geq 45	Wear Ring 	Cut Wear Ring 	
Mineral oil based hydraulic fluid, bio-oils, water	Steel, chrome plated steel, cast iron, ductile iron	D-A-S Compact Seal 		
Mineral oil based hydraulic fluid, bio-oils, water	Steel, chrome plated steel, cast iron, ductile iron	DA17 Wiper 		
Mineral oil based hydraulic fluid, fire retardant hydraulic fluids	Chrome plated steel, cast iron, ductile iron	U-Cup 	Metric DA22 Wiper 	Wynseal 
Mineral oil based hydraulic fluid, bio-oils	Steel, chrome plated steel, cast iron	Slydring® 	Cut Slydring® 	
Mineral oil based hydraulic fluid, bio-oils, water, air	Steel, chrome plated steel, HRC \geq 55	Glyd Ring® HPR 	Glyd Ring® T 	Stepseal® K 
Mineral oil based hydraulic fluid, bio-oils, water, air	Steel, chrome plated steel, hard anodized aluminum HRC \geq 55	Variseal™ 	Roto Glyd Ring® 	
Mineral oil based hydraulic fluid, bio-oils	Steel, chrome plated steel, cast iron	Stepseal® K 	Glyd Ring® T 	Excluder® 
Mineral oil based hydraulic fluid/fire retardant hydraulic fluid	Steel, chrome plated steel, cast iron	Stepseal® K 		Excluder® 
Hydraulic oil, mineral oils, grease, gear oil	Steel, chrome plated steel, cast iron	Glyd Ring® HPR 	Back-up Ring 	Turcon®CST™ Seal 
Hydraulic oil, mineral oils, grease, gear oil	Steel, chrome plated steel, cast iron, ductile iron	B+S U-Cup 		Imperial DA22 Wiper 

Data on other available materials, provided upon request.











Basic Seals





Type	Sealing Material										Applications	Operating Range		
	Turcon*	Zurcon*	Turcite*	Luytex*	HIMod*	PTFE	Elastomeric	Polyurethane	Other Polymeric	Metal		Pressure MPa bar (psi)	Temp. °C (°F)	Speed m/s (ft/s)
O-Ring  general purpose							•	•			     D	to 200 MPa 2000 bar (29400 psi)	-60°C +260°C (-76°F +500°F)	0.5 m/s (1.5 ft/s)
FEP O-Ring  chemical industry aggressive media							•		•		     D	to 25 MPa 250 bar (3675 psi)	-60°C +200°C (-76°F +392°F)	—
PTFE O-Ring  chemical industry aggressive media						•					     D	to 40 MPa 400 bar (5880 psi)	-200°C +260°C (-328°F +500°F)	—
Kalrez® O-Ring  chemical industry aggressive media <small>*Trademark of DuPont</small>							•				     D	to 200 MPa 2000 bar (29400 psi)	-15°C +316°C (+5°F +600°F)	—
Zalak® O-Ring  chemical industry general purpose <small>™ Trademark of DuPont</small>							•				     D	to 200 MPa 2000 bar (29400 psi)	-50°C +250°C (-58°F +482°F)	—
QUAD-RING® Seal  general purpose twist free (4 lips) <small>*Trademark of Quadion Corporation</small>							•				     D	to 40 MPa 400 bar (5880 psi)	-60°C +200°C (-76°F +392°F)	0,5 m/s (1.5 ft/s)
Kantseal  general purpose for flanges							•				     D	to 50 MPa 500 bar (7350 psi)	-30°C +200°C (-22°F +392°F)	—
Seal Kits  O-Ring Kits QUAD-RING® Kits Kantseal Kits							•				     D	—	-30°C +200°C (-22°F +392°F)	—

KEY TO APPLICATIONS: Reciprocating =  Rotary =  Oscillating =  Helix =  Static =  Single Acting = **S** Double Acting= **D**































Basic Seals (Continued)





Type	Sealing Material										Applications	Operating Range		
	Turcon*	Zurcon*	Turcite*	Luytex*	HIMod*	PTFE	Elastomeric	Polyurethane	Other Polymeric	Metal		Pressure MPa bar (psi)	Temp. °C (°F)	Speed m/s (ft/s)
 Back-up Ring general purpose for O-Ring and QUAD-RING®	•					•	•	•	•		 	80 MPa 800 bar (11760 psi)	-60°C +200°C (-76°F +392°F)	0,5 m/s (1.5 ft/s)
 Back-up Ring (Concave) general purpose for O-ring very high pressure	•					•	•	•	•		 	250 MPa 2500 bar (36750 psi)	-60°C +200°C (-76°F +392°F)	0,5 m/s (1.5 ft/s)
 Turcon®Double Delta industrial hydraulic light and medium duty	•										 	to 35 MPa 350 bar (5145 psi)	-54°C +200°C (-65°F +392°F)	15 m/s (50 ft/s)

KEY TO APPLICATIONS: Reciprocating =  Rotary =  Oscillating =  Helix =  Static =  Single Acting = **S** Double Acting= **D**



























Fluid Sealing Systems - Piston Seals





Type	Sealing Material										Applications	Operating Range		
	Turcon®	Zurcon®	Turcite®	Luytex®	HiMod®	PTFE	Elastomeric	Polyurethane	Other Polymeric	Metal		Pressure MPa bar (psi)	Temp. °C (°F)	Speed m/s (ft/s)
 Turcon®Glyd Ring® T hydraulic gen. machine operation machine tools mobile hydraulics	•	•									 	to 80 MPa 800 bar (11750 psi)	-54°C +200°C (-65°F +392°F)	15 m/s (50 ft/s)
 Turcon®AQ Seal® hydraulic medium operation	•						•				  	to 40 MPa 400 bar (5880 psi)	-54°C +200°C (-65°F +392°F)	2 m/s (6 ft/s)
 Turcon®AQ-Seal® 5 hydraulic piston accumulator	•						•				  	to 60 MPa 600 bar (8820 psi)	-54°C +200°C (-65°F +392°F)	3 m/s (10 ft/s)
 Turcon®Stepseal® K hydraulic gen. machine operation machine tools mobile hydraulics	•	•									 	to 80 MPa 800 bar (11750 psi)	-54°C +200°C (-65°F +392°F)	15 m/s (50 ft/s)
 Zurcon®Wynseal hydraulic light hydraulic medium hydraulic		•					•				 	to 25 MPa 250 bar (3675 psi)	-35°C +80°C (-31°F +176°F)	0,8 m/s (2.5 ft/s)
 D-A-S Compact Seal hydraulic standard cylinder							•		•		 	to 35 MPa 350 bar (5145 psi)	-30°C +110°C (-22°F +232°F)	0,5 m/s (1.5 ft/s)
 Turcon®Variseal™M2 hydraulic chemical industry aggressive media	•	•									 	to 45 MPa 450 bar (6651 psi)	-70°C +260°C (-94°F +500°F)	15 m/s (50 ft/s)
 Turcon®Variseal™W pressure switches control valves food processing equipment	•	•									 	to 20 MPa 200 bar (2940 psi)	-70°C +230°C (-94°F +446°F)	15 m/s (50 ft/s)
 Turcon®CST™ Seal hydraulic mobile hydraulics	•										 	to 50 MPa 500 bar (7500 psi)	-54°C +205°C (-65°F +400°F)	1,5 m/s (5,0 ft/s)

KEY TO APPLICATIONS: Reciprocating =  Rotary =  Oscillating =  Helix =  Static =  Single Acting = **S** Double Acting= **D**



Fluid Sealing Systems - Rod Seals

Type	Sealing Material										Applications	Operating Range		
	Turcon®	Zurcon®	Turcite®	Luytex®	HiMod®	PTFE	Elastomeric	Polyurethane	Other Polymeric	Metal		Pressure MPa bar (psi)	Temp. °C (°F)	Speed m/s (ft/s)
Turcon®Stepseal®K  hydraulic gen. machine operation machine tools mobile hydraulics	•	•									 	to 80 MPa 800 bar (11750 psi)	-54°C +200°C (-65°F +392°F)	15 m/s (50 ft/s)
Zurcon®Rimseal  hydraulic gen. machine operation machine tools mobile hydraulics		•									 	to 25 MPa 250 bar (3675 psi)	-30°C +100°C (-22°F +212°F)	1 m/s (3 ft/s)
Zurcon®U-Cup  hydraulic standard cylinders		•						•			 	to 40 MPa 400 bar (5800 psi)	-40°C +100°C (-40°F +212°F)	0,5 m/s (1.5 ft/s)
Turcon®Variseal™M2  hydraulic chemical industry gen. mech. applications aggressive media food processing equipment	•	•									 	to 45 MPa 450 bar (6615 psi)	-70°C +260°C (-94°F +500°F)	15 m/s (50 ft/s)
Turcon®Variseal™W  chemical industry gen. mech. applications	•										 	to 20 MPa 200 bar (2940 psi)	-70°C +230°C (-94°F +446°F)	15 m/s (50 ft/s)
Turcon®Glyd Ring®T  hydraulic gen. machine operation machine tools mobile hydraulics	•	•									 	to 80 MPa 800 bar (11750 psi)	-54°C +200°C (-65°F +392°F)	15 m/s (50 ft/s)
Zurcon®L-Cup®  hydraulic standard cylinder		•									 	to 40 MPa 400 bar (5800 psi)	-30°C +80°C (-22°F +176°F)	0,5 m/s (1,5 ft/s)
Glyd Ring®HPR  hydraulic general machine operation machine tools mobile hydraulics	•										 	to 50 MPa 500 bar (7500 psi)	-54°C +120°C (-65°F +248°F)	1,5 m/s (5,0 ft/s)

KEY TO APPLICATIONS: Reciprocating =  Rotary =  Oscillating =  Helix =  Static =  Single Acting = **S** Double Acting= **D**





















Fluid Sealing Systems - Scrapers

Type	Sealing Material										Applications	Operating Range		
	Turcon*	Zurcon*	Turcite*	Luytex*	HiMod*	PTFE	Elastomeric	Polyurethane	Other Polymeric	Metal		Pressure MPa bar (psi)	Temp. °C (°F)	Speed m/s (ft/s)
Turcon®Excluder®2 hydraulic light hydraulic machine tools	•	•									S	—	-54°C +200°C (-65°F +392°F)	15 m/s (50 ft/s)
Turcon®Excluder®5 hydraulic medium hydraulic mobile hydraulics	•	•									S	—	-54°C +200°C (-65°F +392°F)	15 m/s (50 ft/s)
Turcon®Excluder®500 hydraulic gen. mech. applications mobile hydraulic		•									S	—	-30°C +100°C (-22°F +212°F)	1 m/s (3 ft/s)
Rod Scraper DA22 hydraulic general purpose								•			S	2 MPa 20 bar (30 psi)	-35°C +100°C (-31°F +212°F)	1 m/s (3 ft/s)
Rod Scraper DA17 hydraulic general purpose							•				S	—	-30°C +110°C (-22°F +230°F)	1 m/s (3 ft/s)
Rod Scraper ASW hydraulic general purpose								•			S	—	-35°C +100°C (-31°F +212°F)	1 m/s (3 ft/s)
Rod Scraper SA hydraulic general purpose							•				S	—	-30°C +110°C (-22°F +230°F)	1 m/s (3 ft/s)
Rod Scraper A hydraulic general purpose							•				S	—	-30°C +110°C (-22°F +230°F)	1 m/s (3 ft/s)
Metal Scraper hydraulic general purpose							•			•	S	—	-40°C +120°C (-40°F +250°F)	1 m/s (3 ft/s)







KEY TO APPLICATIONS: Reciprocating = Rotary = Oscillating = Helix = Static = Single Acting = **S** Double Acting= **D**















Fluid Sealing Systems - Wear Rings





Type	Sealing Material										Applications	Operating Range		
	Turcon®	Zurcon®	Turcite®	Luytex®	HiMod®	PTFE	Elastomeric	Polyurethane	Other Polymeric	Metal		Dynamic Load N/mm ² (Lbf/in ²)	Temp. °C (°F)	Speed m/s (ft/s)
 Turcite® Slydring® hydraulic general purpose standard cylinders high speed			•								    	15 N/mm ² (2175 lbs/in ²)	-60°C +200°C (-76°F +392°F)	15 m/s (50 ft/s)
 Zurcon® Wear Ring hydraulic general purpose standard cylinders		•									    	25 N/mm ² (3625 lbs/in ²)	-60°C +110°C (-76°F +232°F)	2 m/s (6 ft/s)
 Luytex® Wear Ring hydraulic general purpose high pressure standard cylinders			•								    	to 90 N/mm ² (13000 lbs/in ²)	-60°C +130°C (-76°F +266°F)	1 m/s (3 ft/s)

Fluid Sealing Systems - Pneumatic

Type	Sealing Material										Applications	Pressure MPa bar (psi)	Temp. °C (°F)	Speed m/s (ft/s)
	Turcon®	Zurcon®	Turcite®	Luytex®	HiMod®	PTFE	Elastomeric	Polyurethane	Other Polymeric	Metal		to 1.2 MPa 12 bar (175 psi)	-30°C +100°C (-22°F +212°F)	1 m/s (3 ft/s)
 Complete Pneumatic Piston PK general purpose							•				    	to 1.2 MPa 12 bar (175 psi)	-30°C +100°C (-22°F +212°F)	1 m/s (3 ft/s)



















Rotary Seals





Type	Sealing Material										Applications	Pressure MPa bar (psi)	Temp. °C (°F)	Speed m/s (ft/s)
	Turcon®	Zurcon®	Turcite®	Luytex®	HiMod®	PTFE	Elastomeric	Polyurethane	Other Polymeric	Metal				
 Radial Oil Seal general purpose general mechanical applications							•				    	to 0.05 MPa 0.5 bar (7.5 psi)	-40°C +170°C (-40°F +338°F)	12 m/s (39 ft/s)
 Radial Oil Seal (Pressure Seal) general purpose general mechanical applications							•				    	to 0.5 MPa 5.0 bar (7.5 psi)	-40°C +170°C (-40°F +338°F)	8 m/s (26 ft/s)

KEY TO APPLICATIONS: Reciprocating =  Rotary =  Oscillating =  Helix =  Static =  Single Acting = **S** Double Acting= **D**









Rotary Seals (Continued)

Type	Sealing Material										Applications	Operating Range				
	Turcon®	Zurcon®	Turcite®	Luytex®	HIMod®	PTFE	Elastomeric	Polyurethane	Other Polymeric	Metal		Pressure MPa bar (psi)	Temp. °C (°F)	Speed m/s (ft/s)		
Shaft Repair Kit 											•		—	—	—	
Sealing Cap 							•					•	*	—	-30°C +100°C (-22°F +212°F)	—
Varilip® Radial Lip Shaft Seal  <p>general purpose general mech. applications chemical industry</p>	•											 S 	to 2.0 MPa 20 bar (295 psi)	-60°C +200°C (-76°F +392°F)	40 m/s (132 ft/s)	
V-Seal  <p>general purpose general mech. applications</p>							•					 S 	to 0.0 MPa 0 bar (0 psi)	-40°C +180°C (-40°F +376°F)	12 m/s (39 ft/s)	
Axial Shaft Seal  <p>general purpose for roller bearings</p>							•					 S	to 0.5 MPa 5.0 bar (74 psi)	-40°C +200°C (-40°F +392°F)	30 m/s (100 ft/s)	
Turcon® Roto Glyd Ring®  <p>hydraulic general purpose rotary applications</p>	•											 D 	to 30 MPa 300 bar (4410 psi)	-54°C +200°C (-65°F +392°F)	2 m/s (6 ft/s)	
Turcon® Roto Variseal™  <p>general mech. applications chemical industry</p>	•											 S 	to 15 MPa 150 bar (2205 psi)	-100°C +260°C (-148°F +500°F)	2 m/s (6 ft/s)	
Heavy Duty Seal  <p>general purpose heavy duty</p>											•	 S	to 0.3 MPa 3.0 bar (45 psi)	-40°C +120°C (-40°F +248°F)	4 m/s (13 ft/s)	







KEY TO APPLICATIONS: Reciprocating =  Rotary =  Oscillating =  Helix =  Static =  Single Acting = **S** Double Acting= **D**







Static Seals

Type	Sealing Material										Applications	Operating Range			
	Turcon®	Zurcon®	Turcite®	Luytex®	HiMod®	PTFE	Elastomeric	Polyurethane	Other Polymeric	Metal		Pressure MPa bar (psi)	Temp. °C (°F)	Speed m/s (ft/s)	
Wills Rings®  general purpose flange applications											•	✱ D	to 1000 MPa 10000 bar (147000 psi)	cryogenic to +850°C (1500°F)	—
Turcon® Variseal™ H  chemical industry gasket fittings		•										✱ S	to 80 MPa 800 bar (11760 psi)	-120°C +260°C (-184°F +500°F)	—
Turcon® Variseal™ HF  chemical industry flange fittings		•										✱ S	to 80 MPa 800 bar (11760 psi)	-200°C +260°C (-328°F +500°F)	—
SAE Flange Seal  mobile hydraulic general mech. applications							•	•				✱ S	to 42 MPa 420 bar (6150 psi)	-40°C +100°C (-40°F +212°F)	—
U-Seal  general purpose general mech. applications							•			•		✱ D	to 100 MPa 1000 bar (14700 psi)	-30°C +200°C (-22°F +392°F)	—
Airseal 												✱ D	to 1 MPa 10 bar (145 psi)	-50°C +220°C (-58°F +428°F)	—































Linear Bearings & Bushes

Turcite®-B Slydway®  general mech. applications machine tools			•								 ✱	9 N/mm ² (1300 Lbf/in ²)	to 260°C (500°F)	1 m/s (3 ft/s)
Luytex® & Turcite® Bearing Bushes  general mech. applications			•	•							 ✱  	DYNAMIC 80 N/mm ² (11600 Lbf/in ²)	-40°C +100°C (-40°F +212°F)	6 m/s (20 ft/s)













KEY TO APPLICATIONS: Reciprocating =  Rotary =  Oscillating =  Helix =  Static =  Single Acting = **S** Double Acting= **D**







Custom Made Components

Type	Sealing Material										Applications	Operating Range		
	Turcon*	Zurcon*	Turcite*	Luytex*	HiMod*	PTFE	Elastomeric	Polyurethane	Other Polymeric	Metal		Load N/mm ² (Lbf/in ²)	Temp. °C (°F)	Speed m/s (ft/s)
Ventseal 							•				    	—	-40°C +200°C (-40°F +392°F)	—
Custom made Rubber Products 							•	•	•		    	—	to 316°C (600°F)	—
Custom made PTFE Components 						•					    	—	to 260°C (500°F)	—
Ground Balls 							•				    	—	-30°C +200°C (-22°F +392°F)	—
Custom made HiMod®High Modulus Plastics 					•						    	—	to 300°C (572°F)	—

Miscellaneous

Assembly Tool M56A 											    	—	—	—
M22 Pliers  general purpose repair set for rod seals											    	—	—	—

KEY TO APPLICATIONS: Reciprocating =  Rotary =  Oscillating =  Helix =  Static =  Single Acting = **S** Double Acting= **D**

Application Examples



ITEM	DESCRIPTION	MATERIAL
1	GLYD RING® T	TURCON® T46
2	SLYDRING®	TURCITE® T47
3	SLYDRING®	TURCITE® T47
4	STEPSEAL®	TURCON® T46
5	EXCLUDER®	TURCON® T46

OPERATING CONDITIONS
 PRESSURE: 250 BAR
 TEMPERATURE: -40° C TO 200° C (WITH SPECIAL ELASTOMERS)
 VELOCITY: 15 METERS/SECOND MAX
 SERVICE: HIGH SPEED FACTORY MACHINERY
 EXAMPLE: PLASTIC INJECTION MOLDING MACHINE

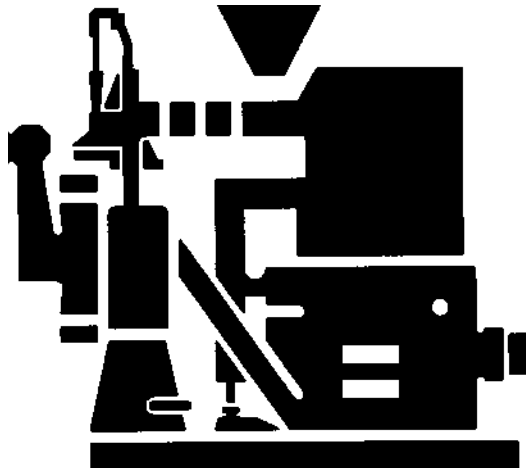

ITEM	DESCRIPTION	MATERIAL
1	BUFFER RING	TURCON® T42
2	SLYDRING®	TURCITE® T47
3	SLYDRING®	TURCITE® T47
4	FLANGED VARISEAL™	TURCON® T40
5	OIL SEAL	METAL HOUSING ELASTOMER LIP

OPERATING CONDITIONS
 PRESSURE: 310 BAR
 TEMPERATURE: -40° C TO 200° C (WITH SPECIAL ELASTOMERS)
 VELOCITY: 10 SURFACE METERS/SECOND MAX
 SERVICE: HIGH VELOCITY ROTARY SEALING
 EXAMPLE: PLASTIC INJECTION MOLDING CYLINDER



Application Examples

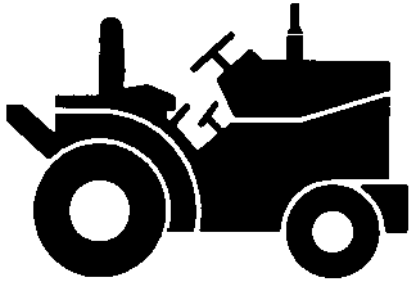

ITEM	DESCRIPTION	MATERIAL
1	DAS COMPACT SEAL	VARIOUS
2	B+S U-CUP	ZURCON® Z94
3	DA17 WIPER	NITRILE

OPERATING CONDITIONS
 PRESSURE: 150 BAR
 TEMPERATURE: -30°C TO 100°C
 VELOCITY: 0.5 METERS/SECOND MAX
 SERVICE: POSITIVE SEALING,
 LIGHT DUTY
 EXAMPLE: AGRICULTURAL CYLINDER



ITEM	DESCRIPTION	MATERIAL
1	GLYD RING® T	TURCON® T46
2	WEAR RING	LUYTEX® C380
3	4mm SLYDRING®	TURCITE® T47
4	4mm SLYDRING®	TURCITE® T47
5	SLYDRING®	LUYTEX® C380
6	STEPSEAL® K	TURCON® T46
7	B+S U-CUP	ZURCON® Z94
8	WIPER	METAL HOUSING POLYURETHANE

OPERATING CONDITIONS
 PRESSURE: 310 BAR (500 BAR SPIKE)
 TEMPERATURE: -40°C TO 100°C
 VELOCITY: 1 METERS/SECOND MAX
 SERVICE: MEDIUM DUTY MOBILE EQUIPMENT
 EXAMPLE: BLADE CYLINDER



ITEM	DESCRIPTION	MATERIAL
1	GLYD RING® T	TURCON® T46
2	WEAR RING	LUYTEX® C380
3	WEAR RING	LUYTEX® C380
4	STEPSEAL® K	TURCON® T46
5	B+S U-CUP	ZURCON® Z94
6	DA22 WIPER	POLYURETHANE

OPERATING CONDITIONS
 PRESSURE: 250 BAR
 TEMPERATURE: -40°C TO 100°C
 VELOCITY: 0.5 METERS/SECOND MAX
 SERVICE: MEDIUM DUTY MOBILE EQUIPMENT
 EXAMPLE: STEERING CYLINDER

Application Examples



ITEM	DESCRIPTION	MATERIAL
1	CST™ SEAL	TURCON® T46
2	WEAR RING	LUYTEX® C380
3	4 MM SLYDRING®	TURCITE® T47
4	4 MM SLYDRING®	TURCITE® T47
5	SLYDRING®	LUYTEX® C380
6	GLYD RING® HPR	TURCON® T46
7	B+S U-CUP	ZURCON® Z94
8	WIPER	METAL HOUSING POLYURETHANE

OPERATING CONDITIONS

PRESSURE: 500 BAR (800 BAR SPIKE)
 TEMPERATURE: -40°C TO 100°C
 VELOCITY: 0.5 METERS/SECOND MAX
 SERVICE: HEAVY DUTY HIGH PRESSURE EXCAVATORS
 EXAMPLE: BOOM, BUCKET, AND ARM CYLINDER

ITEM	DESCRIPTION	MATERIAL
1	QUAD-RING® SEAL	NITRILE
2	WEAR RING®	LUYTEX® C380
3	ROTOGLYDRING® O-RING	TURCON® T40 NITRILE
4	QUAD-RING® SEAL	X-SEL NITRILE
5	BACK-UP RING	TURCON® T01
6	WEAR RING	LUYTEX® C380

OIL PORT	MAX OPERATING PRESSURE (BAR)
P1	300
P2	300
P3	300
P4	150
P5	150

OPERATING CONDITIONS

PRESSURE: VARIOUS (SEE CHART)
 TEMPERATURE: -30°C TO 110°C
 VELOCITY: 2 SURFACE METERS/SECOND MAX
 SERVICE: MOBILE EQUIPMENT
 EXAMPLE: ROTARY MANIFOLD



Application Examples

⌀

OPERATING CONDITIONS

PRESSURE: 200 BAR
 TEMPERATURE: -150°C TO 250°C
 VELOCITY: 2 SURFACE METERS/SECOND
 SERVICE: FAST ROTARY
 EXAMPLE: MACHINE TOOL SWIVEL

ITEM	DESCRIPTION	MATERIAL
1	FLANGED VARISEAL™	TURCON®

OPERATING CONDITIONS

PRESSURE: 250 BAR MAX
 TEMPERATURE: -30°C TO 120°C
 VELOCITY: 0,5 SURFACE METERS/SECOND MAX
 SERVICE: LIGHT DUTY ROTARY
 EXAMPLE: HIGH PRESSURE VALVE

ITEM	DESCRIPTION	MATERIAL
1	X-SEL QUAD-RING® SEAL	NITRILE
2	BACKUP RING®	TURCON®

ITEM	DESCRIPTION	MATERIAL
1	V-SEAL	NITRILE

⌀

OPERATING CONDITIONS

PRESSURE: 0.5 BAR MAX
 TEMPERATURE: -40°C TO 250°C
 VELOCITY: 2 SURFACE METERS/SECOND
 SERVICE: FAST ROTARY
 EXAMPLE: MACHINE TOOL SWIVEL

ITEM	DESCRIPTION	MATERIAL
1	V-SEAL	NITRILE

⌀

OPERATING CONDITIONS

PRESSURE: 0.5 BAR MAX
 TEMPERATURE: -40°C TO 100°C
 VELOCITY: 10 SURFACE METERS/SECOND MAX
 SERVICE: FAST ROTARY
 EXAMPLE: LABYRINTH SEALING SYSTEM, MACHINE TOOL

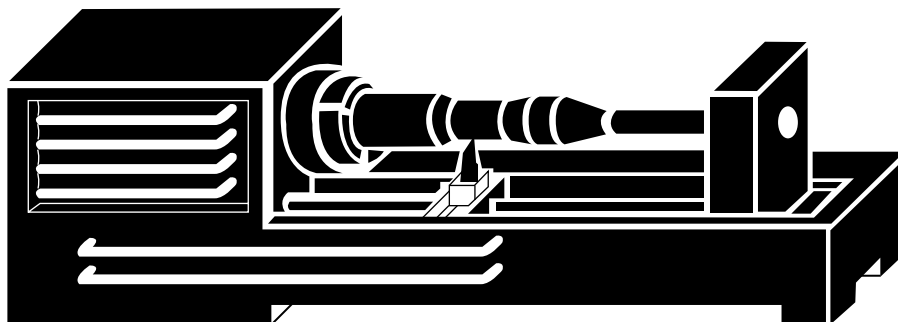



ITEM	DESCRIPTION	MATERIAL
1	X-SEL® QUAD-RING® SEAL	NITRILE
2	ROD/PISTON VARISEAL™	TURCON®
3	VARISEAL™ FACE SEAL	TURCON®

OPERATING CONDITIONS

PRESSURE: 450 BAR
 TEMPERATURE: -65°C TO 200°C
 (WITH SPECIAL ELASTOMERS)
 VELOCITY: SLOW (ROTARY & LINEAR)
 SERVICE: HIGH PRESSURE ROTARY
 EXAMPLE: CONTROL VALVE

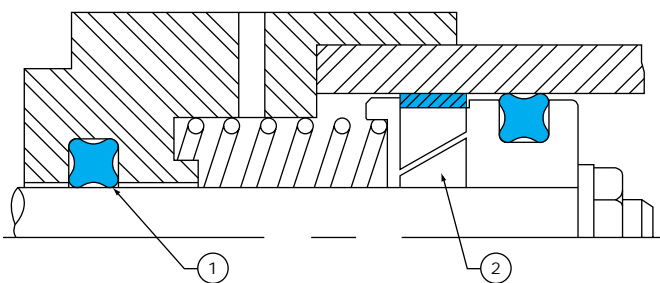
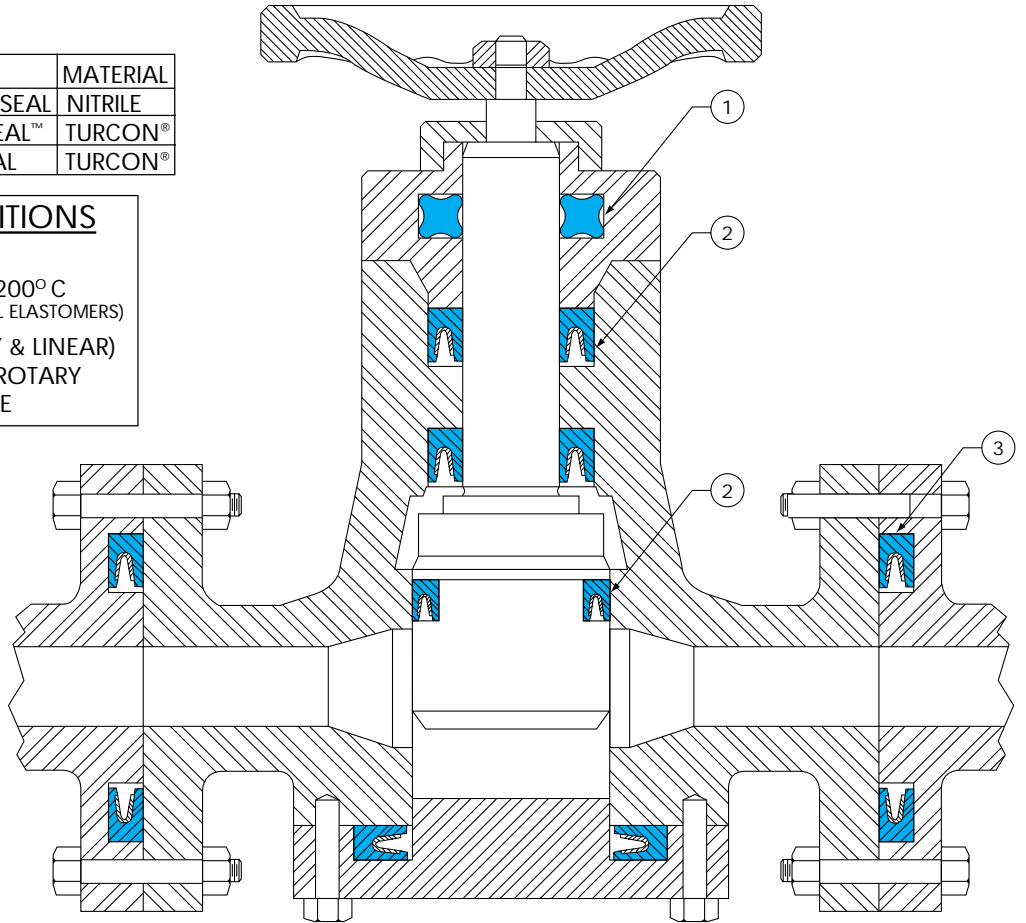

OPERATING CONDITIONS

PRESSURE: 50 BAR MAX
 TEMPERATURE: -30°C TO 120°C
 VELOCITY: 0,5 METERS/SECOND MAX
 SERVICE: LIGHT DUTY SHORT STROKE
 EXAMPLE: CONTROL VALVE

ITEM	DESCRIPTION	MATERIAL
1	QUAD-RING® SEAL	NITRILE
2	SLYDRING®	TURCITE® T47

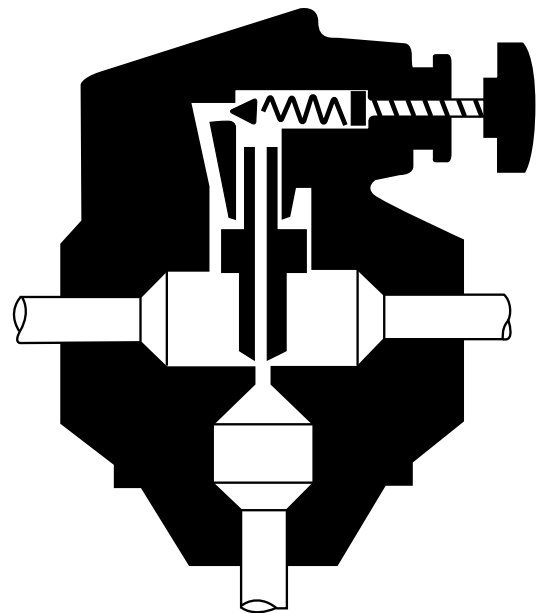



Application Examples

ITEM	DESCRIPTION	MATERIAL
1	EXCLUDER® 5	TURCON® T46
2	BACKUP RING	TURCON®
3	O-RING	NITRILE
4	STEPSEAL® K	TURCON® T46

OPERATING CONDITIONS

PRESSURE: 200 BAR
 TEMPERATURE: -40°C TO 130°C
 VELOCITY: 15 METERS/SECOND MAX
 SERVICE: FAST LINEAR MOTION
 EXAMPLE: HYDRAULIC HAMMER

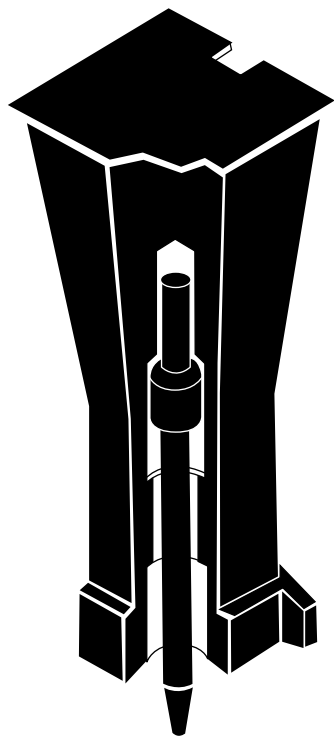

ITEM	DESCRIPTION	MATERIAL
1	WEAR PAD	LUYTEX®

OPERATING CONDITIONS

TEMPERATURE: -40°C TO 250°C
 WITH SPECIAL COMPOUNDS
 VELOCITY: 2 METERS/SECOND MAX
 SERVICE: LINEAR BEARING
 EXAMPLE: PILE DRIVING SIDE BEARING

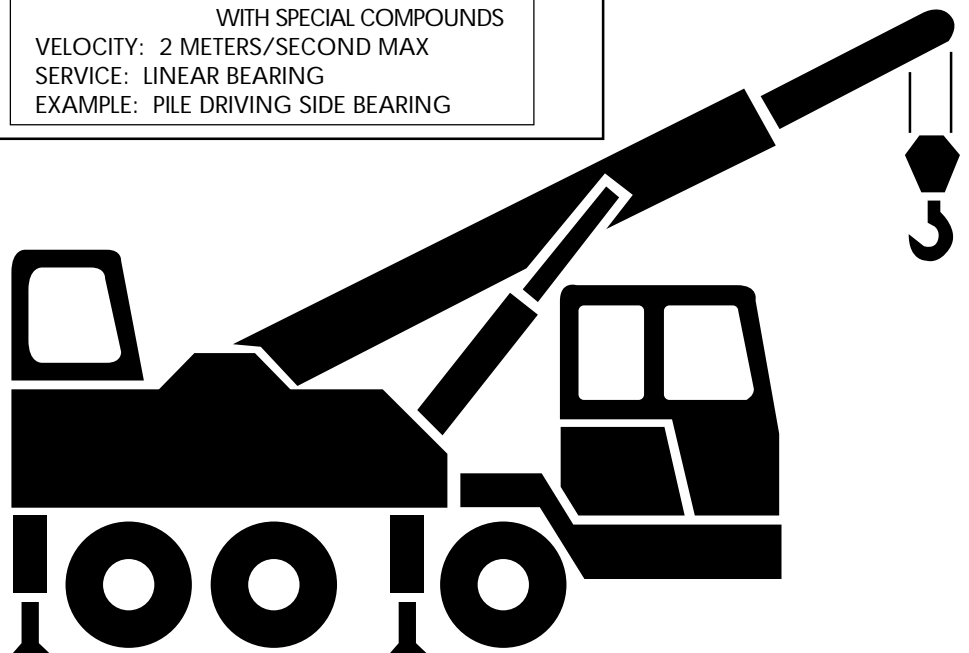

Application Examples



ITEM	DESCRIPTION	MATERIAL
1	OIL SEAL	NITRILE
2	VARILIP®	TURCON® 9
3	V-SEAL	NITRILE

OPERATING CONDITIONS
 PRESSURE: 0,5 BAR MAX
 TEMPERATURE: -40°C TO 120°C
 VELOCITY: 2 METERS/SECOND MAX
 SERVICE: HIGH PRESSURE ROTARY
 EXAMPLE: STEEL MILL GEARBOX

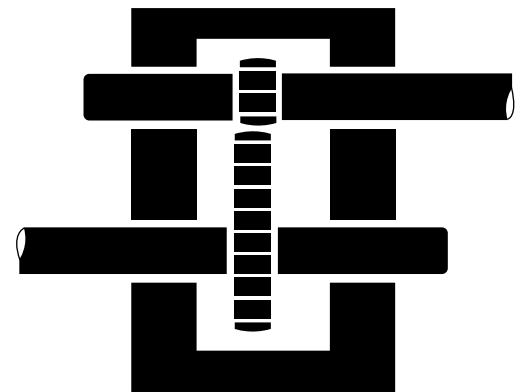

ITEM	DESCRIPTION	MATERIAL
1	V-SEAL	NITRILE

OPERATING CONDITIONS
 TEMPERATURE: -40°C TO 100°C
 VELOCITY: 10 SURFACE METERS/SECOND MAX
 SERVICE: FAST ROTARY
 EXAMPLE: BALL BEARING PROTECTION

ITEM	DESCRIPTION	MATERIAL
1	PRESS FIT BUSHING	LUYTEX®

OPERATING CONDITIONS
 TEMPERATURE: -40°C TO 250°C
 WITH SPECIAL COMPOUNDS
 VELOCITY: 2 METERS/SECOND MAX (1 m/s with load)
 SERVICE: HIGH LOADS, ROTARY
 EXAMPLE: AGRICULTURAL EQUIPMENT
 SPINDLE BUSHING

ITEM	DESCRIPTION	MATERIAL
1	COMPOSITE BEARING	LUYTEX®
2	FLANGED VARISEAL™	TURCON® /STEEL

OPERATING CONDITIONS
 PRESSURE: 200 BAR MAX
 TEMPERATURE: -60°C TO 120°C
 VELOCITY: 2 METERS/SECOND MAX
 (1 m/s with load)
 SERVICE: HIGH PRESSURE ROTARY
 EXAMPLE: STEEL MILL GEARBOX



Application Examples

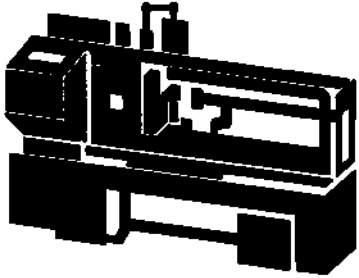

ITEM	DESCRIPTION	MATERIAL
1	GLYD RING® T	TURCON® T46
2	SLYDRING®	TURCITE® T47
3	STEPSEAL®	TURCON® T46
4	SLYDRING®	TURCITE® T47
5	EXCLUDER®	TURCON® T46

OPERATING CONDITIONS
 PRESSURE: 150 BAR
 TEMPERATURE: -40° C TO 200° C (WITH SPECIAL ELASTOMERS)
 VELOCITY: 15 METERS/SECOND MAX
 SERVICE: INSIDE FACTORIES ON MACHINERY
 MEDIUM DUTY, LOW HYSTERESIS
 EXAMPLE: MACHINE TOOL UTILITY CYLINDER

ITEM	DESCRIPTION	MATERIAL
1	VARISEAL™ M	TURCON® T40
2	SLYDRING®	TURCITE® T47
3	SLYDRING®	TURCITE® T47
4	VARISEAL™ M	TURCON® T40

OPERATING CONDITIONS
 PRESSURE: 300 BAR
 TEMPERATURE: -60° C TO 260° C
 VELOCITY: 15 SURFACE METERS/SECOND MAX
 SERVICE: CORROSIVE MEDIA, EXTREME TEMPERATURES
 EXAMPLE: STEEL MILL CYLINDER

OPERATING CONDITIONS
 PRESSURE: 100 BAR
 TEMPERATURE: -40° C TO 205° C
 VELOCITY: 15 METERS/SECOND MAX
 SERVICE: STERILE ENVIRONMENT
 EXAMPLE: FOOD FILLING MACHINE

ITEM	DESCRIPTION	MATERIAL
1	SLYDRING®	TURCON® T01
2	VARISEAL™	TURCON® T01

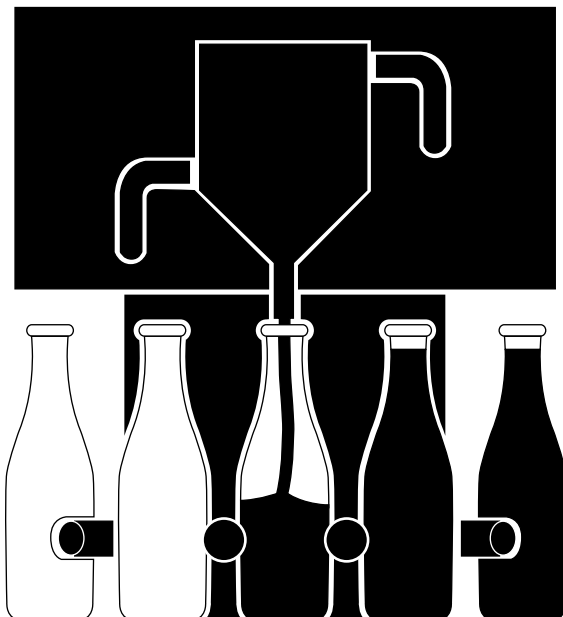
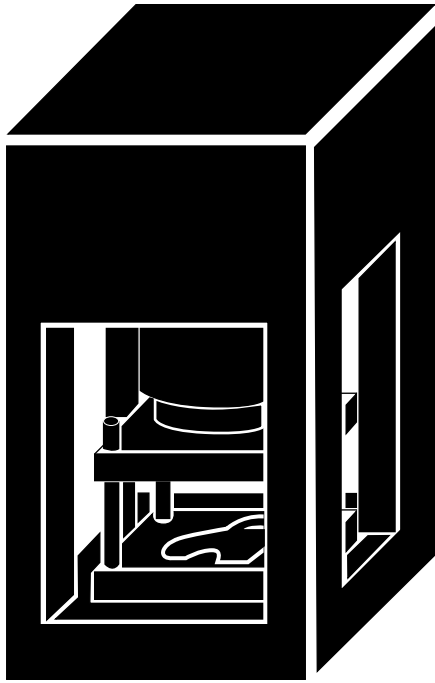

OPERATING CONDITIONS

PRESSURE: 250 BAR (320 BAR MAX)
 TEMPERATURE: -40° C TO 130° C
 VELOCITY: 2 METERS/SECOND MAX
 SERVICE: HIGH PRESSURE FACTORY MACHINERY
 EXAMPLE: LARGE DIAMETER HYDRAULIC PRESS

ITEM	DESCRIPTION	MATERIAL
1	GLYD RING® T	TURCON® T46
2	WEAR RING	LUYTEX® C380
3	4mm SLYDRING®	TURCITE® T47
4	4mm SLYDRING®	TURCITE® T47
5	WEAR RING	LUYTEX® C380
6	STEPSEAL® K	TURCON® T46
7	EXCLUDER® 5	TURCON® T46

用途——標準油壓缸

油壓缸有適用於飛機乃至重型挖土機之各種設計。圖7示S&C封圈系統用於一般工業用標準油壓缸之基本設計。精巧、可靠性高，能因應各種性能上之需求。摩擦小，不振動、保證壽命長，這都是Tuncon及Tuncite材料之特徵。

使用例條件：

壓力：250kgf/cm²

速度：1m/s

衝程：400mm

內徑：125mm

油壓缸桿徑：70mm

表面粗度：1.6S

液體：液壓油

溫度：-30~120℃

推薦元件：

- ①③ 耐磨環 (SLIDE RING) S55915-1250-47A
- ② 複動油封 (GLYD RING) S55044-1250-46N
- ④⑤⑦ 耐磨環 (SLIDE RING) S55809-0700-47A
- ⑥ 單動油封 (STEP SEAL) S55013-0700-46K
- ⑧ 雙唇刮磨封圈 (SCRAPER) DA17-0700-N90
- ⑩⑪ O型環及背托環

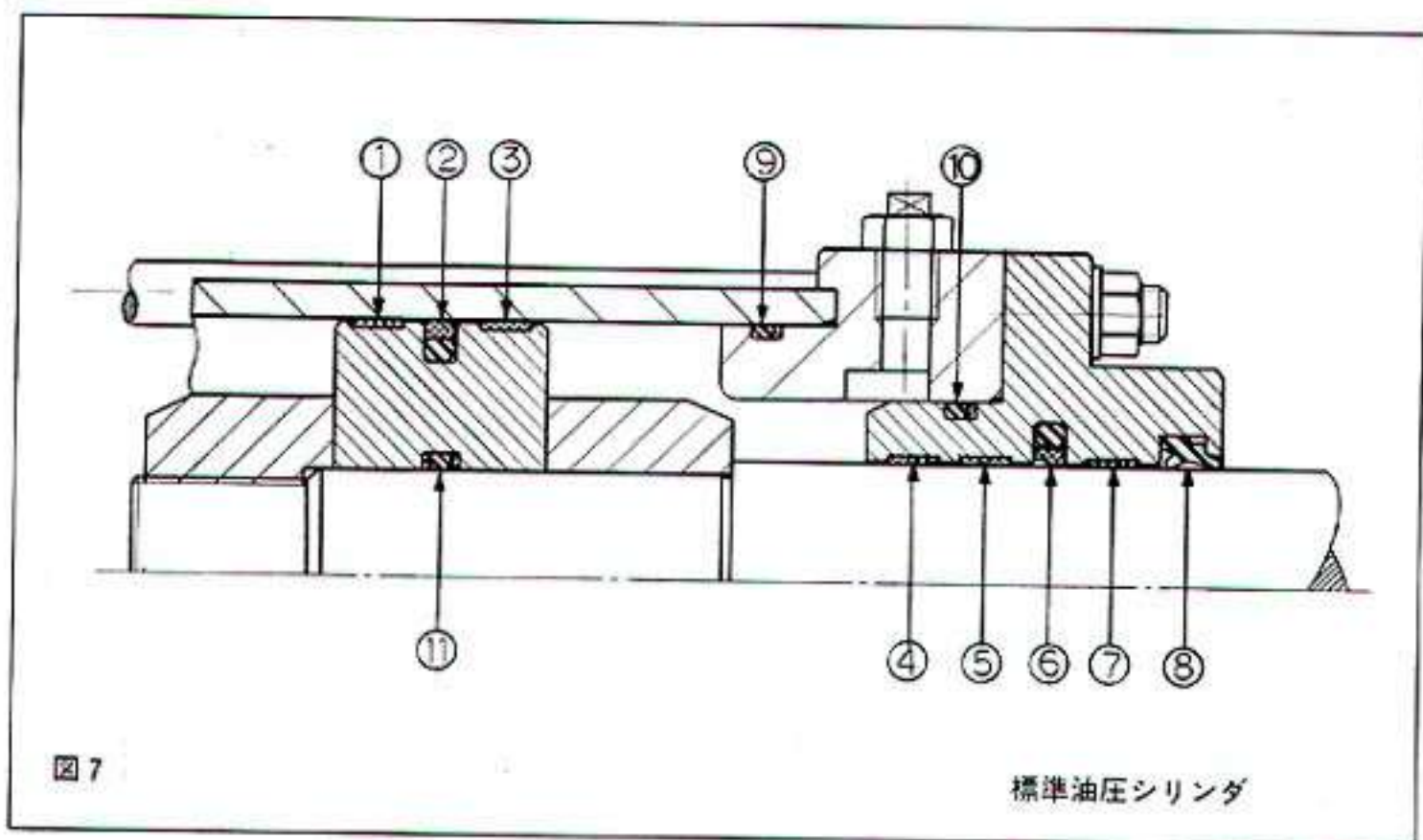

用途——高速油壓缸

高速油壓缸之缸桿封圈系統 (ROD SEALING SYSTEM) 一般在速度增大時須有對應的設計變更。但是活塞封圈系統 (PISTON CYLINDER SYSTEM) 對於速度增大時，缸桿並無多大的反應，一般無須變更設計。

圖8示高速油壓缸採用S&C缸桿封圈系統時由並列之單動油封 (STEP SEALS) 67 及複動之刮塵封圈 9 (Excluder II) 所構成。

這系統中，單動油封 (STEP SEALS) 之後裝有二次封圈，使階段封圈之流體力學效果完全發揮。二次封圈是用來保住通過階段封圈之油膜 (其厚僅4分之幾個微米， $10^{-9}\mu$)。亦即缸桿後退時其所保持之油被送回油壓缸內，因此其摩擦及漏油達到最低程度。

圖中溝A是為單動油封 (STEP SEALS) 之動作而設計之貯油溝。對於長行程之活塞也很有用。

使用例條件：

壓力：140kgf/cm²

速度：8.6m/s

衝程：160mm

活塞內徑：80mm

缸桿直徑：45mm

表面粗度：0.8S

液體：作動油

溫度：60°C

①③推薦元件：耐摩環 (SLIDE RING) S55909-0800-47A

②複動油封 (GLYD RING) S55044-0800-46N

④⑤⑧耐摩環 (SLIDE RING) S55809-0450-47A

⑥⑦單動油封 (STEP SEAL) S55013-0700-46K

⑨刮塵封圈 (EXCLUDER) S56201-0450-46

⑩⑪⑫○型環及背托環



圖 8

高速度油压シリンダ

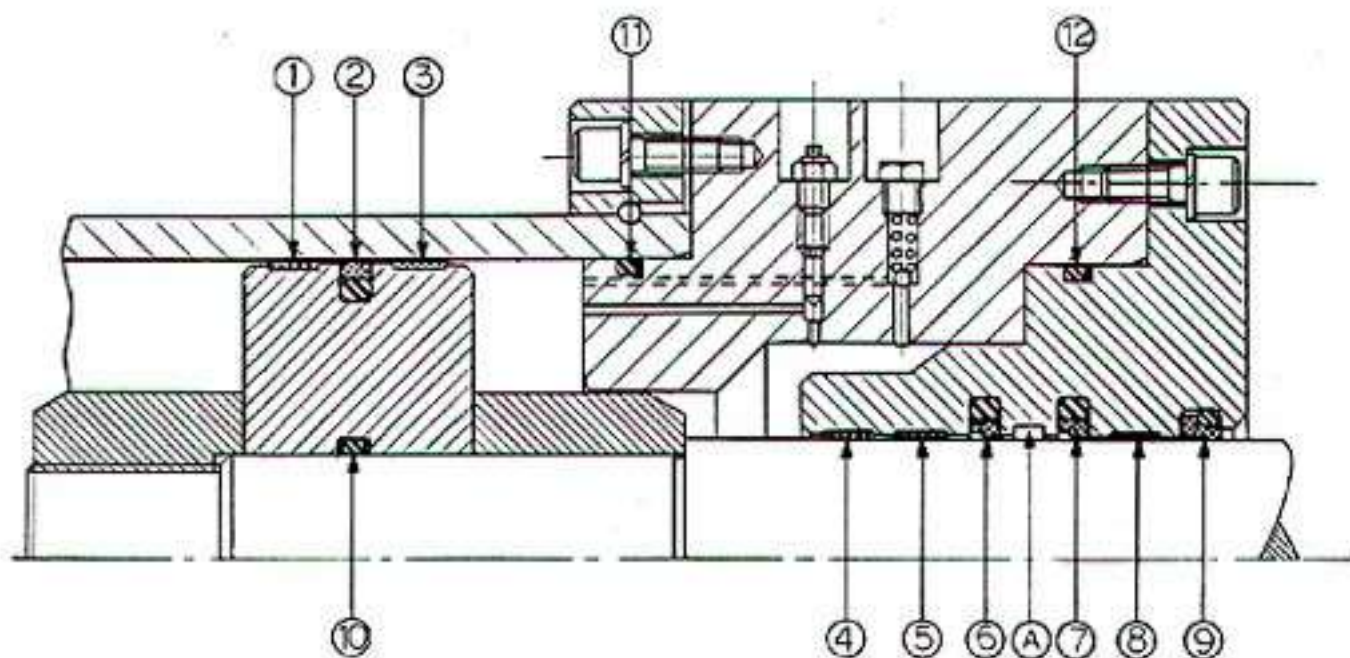

圖 9

用途——ヘビー・デューティ油圧シリンダ

用途——重型 (Heavy duty) 油壓缸

油壓缸用於重負荷之條件下應該採用Tuncite Slide Ring (耐磨環) 及ORKOT Wear Ring (摩耗環) 所組成之承重封圈系統。摩耗環是用以吸取徑向之荷重，而滑動環則是為防止系統之污染及反凝結 (de-jelling) 效應所採取之措施。

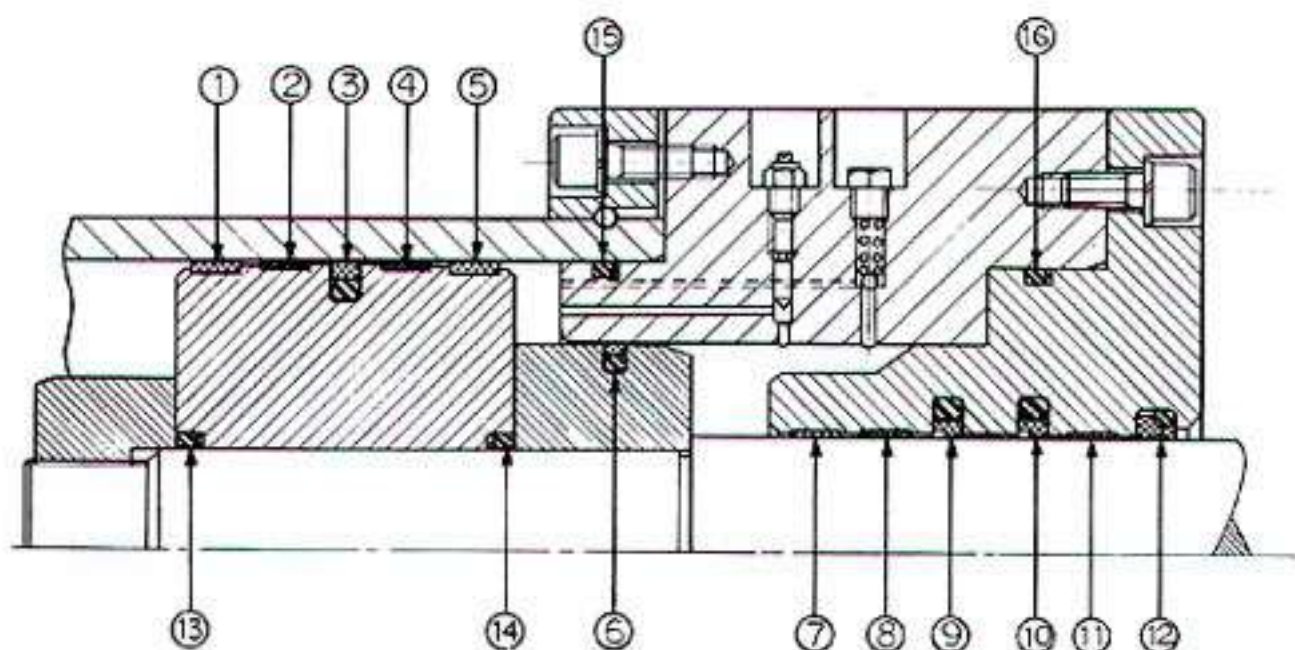
使用例條件

壓力：280~320kgf/cm²

速度：0.8m/s

衝程：1250mm

油壓缸內徑：250mm

缸桿直徑：140mm

表面粗度：0.8~1.6S

液體：作動油溫度：-30~130°C

推薦元件：

- ①③特殊耐磨環 (SLIDE RING)
- ②④耐磨環 (DURATEX[®] 900) BI-50705-2500-A-D900
- ③複動油封 (GLYD RING) S55044-2500-46N
- ⑦耐磨環 (SLIDE RING) S55815-1400-47A
- ⑧⑩耐磨環 (ORKOT[®]) BB-50705-1400-C-TLG
- ⑨單動油封 (STEP SEAL) S55013-1400-46K
- ⑪單動油封 (STEP SEAL) S55013-1400-451K
- ⑫刮塵油封 (EXCLUDER) S56153-1400-451
- ⑬複動油封 (GLYD RING) S55024-2290-451N
- ⑭⑮⑯ O 型環及背托環

用途——氣壓缸

氣壓零件之使用隨自動化機器之進步而日益普及。過去，有封環的運動零件之潤滑是於壓縮空氣中加入油霧以達成潤滑目的。但是氣壓缸用於科技、食品、醫療機器之場合時必須是乾燥氣壓系統才可以。如圖10之設計理念應該可以得到長壽命、低摩擦、無振動的平滑運動。

使用例條件

壓力：7kgf/cm²
速度：0.5m/s~2m/s
衝程：320mm
氣缸內徑：50mm
氣缸桿徑：20mm
表面粗度：0.8~1.6S
流體：乾燥空氣
溫度：5~60°C

推薦元件：

- ①輕型複動油封 S48058-0200-80N
(GLYD RING・LIGHT DUTY)
- ②耐磨環 (SLIDE RING) S55856-0200-10A
- ③⑥輕型複動油封S48059-0280-80N
(GLYD RING・LIGHT DUTY)
- ④耐磨環 (SLIDE RING) S55958-0500-10A
- ⑤輕型複動油封S48059-0500-80N



圖10 用途——エア・シリンダ

用途——集液器

活塞式集液器是以封環的效果分離兩種媒體如油與氣，它必須要能保證平滑的運動且具有低摩擦之特性。

AQ封環具有一次封環及內藏式二次封環組成的獨特結構。一般，於活塞式集液器中欲長期保持氣體壓力時使用之。

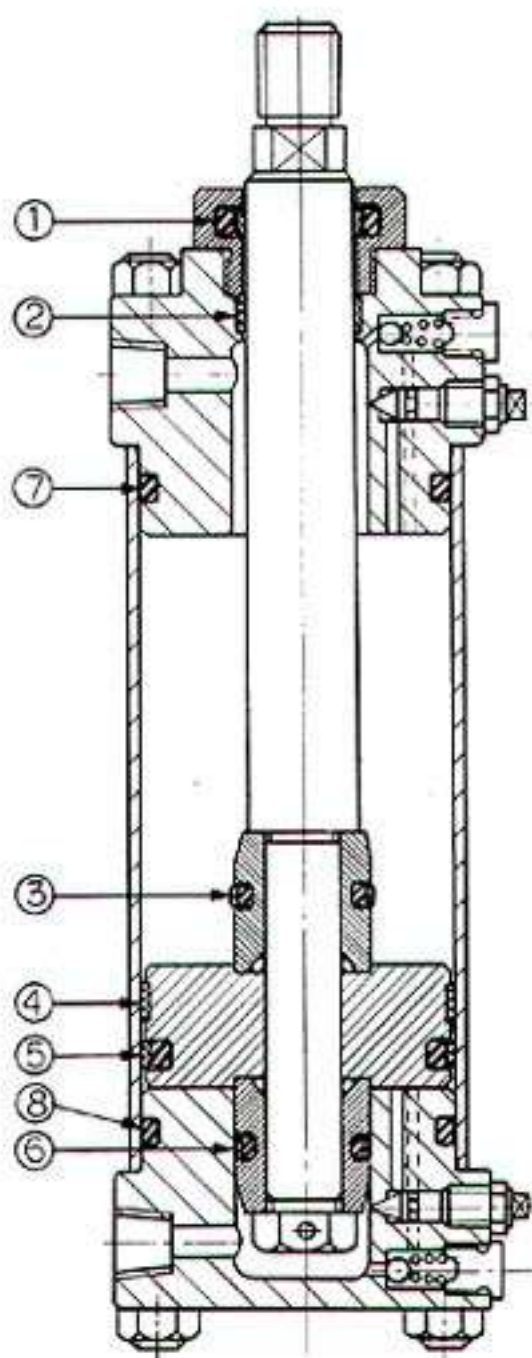
使用例條件：

媒體 1：油

媒體 2：GAS

缸徑：63mm

表面粗度：0.8S

推薦元件

①④耐磨環 (SLIDE RING) S55809-630-10A

②AQ SEAL S56101-0630-46

③單動油封 (STEP SEAL) S55014-0630-46K

⑤⑥O型環及背襯環



図11

用途——アキュムレータ

用途——食品填充用壓力缸

在食品及藥物等需謹慎防範污染媒體之處理機器中，所處理的媒體全部直接曝露於機器之使用材料上，因此機器之所有零件必須是能防止污染、容易清洗、能夠殺菌的設計。

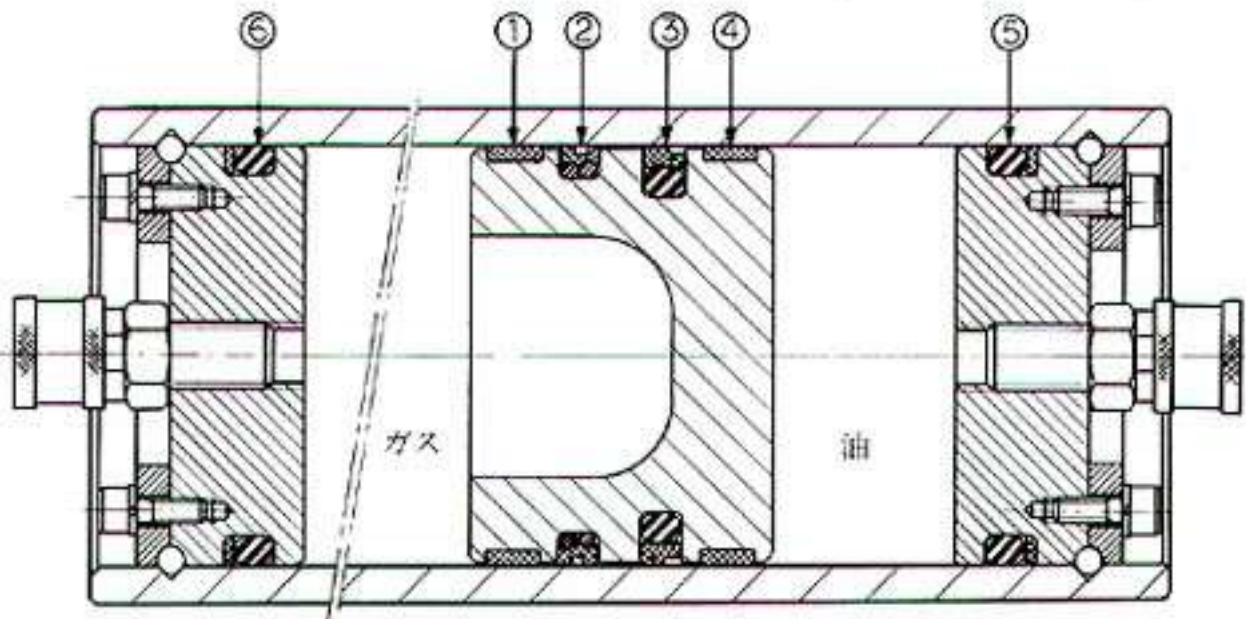
為食品機器等之媒體處理零件而開發的無菌隔離封圈 (VARI-SEAL, HI-CLEAN) 能夠經得起大部分的滅菌處理措施。

使用例條件

媒體：不限

缸內徑：50mm

衝程：125mm

缸：(CYLINDER) 材料：不銹鋼 (STAINLESS)

推薦元件

①無菌隔離封圈S59046-0500-80SHI

②耐磨環 (SLIDE RING) S55909-0500-10A

③動態隔離封圈 (VARI-SEAL) S59046-0500-80S

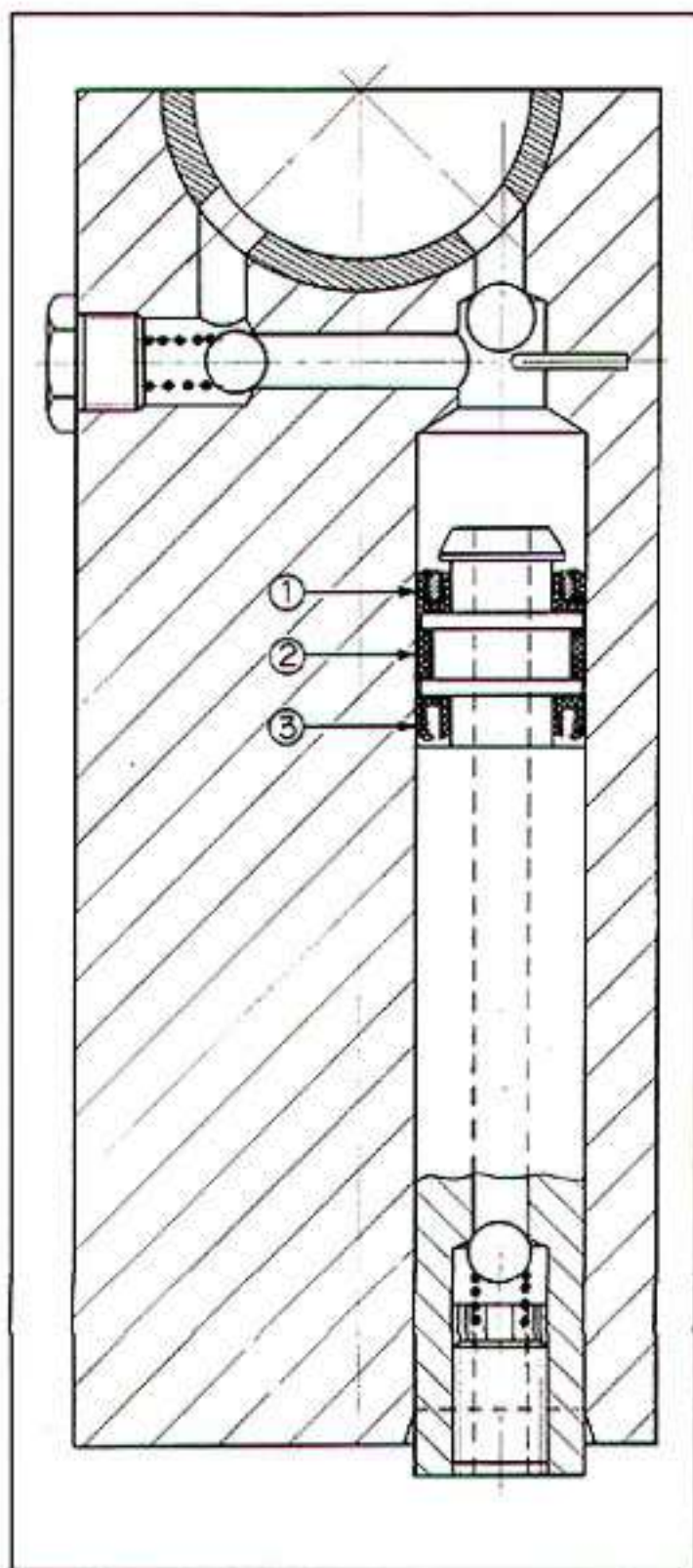

用途——起重機用油壓缸

起重機用油壓缸必須特別考慮的一個問題是在長時間加壓下封密效果的變化。也就是像起重機及千斤頂等長時間支持荷重之狀態下，封密效果不可有任何洩露。

AQ封圈做為活塞封圈時具有阻塞其表面微細之凹凸不平所產生之漏油通路之優點，亦即具有無滴漏 (no drip) 之性能。(參照圖13)

使用例條件

壓力：210kgf/cm² 速度：0.1~0.5m/s
衝程：800mm 缸體內徑：160mm 缸桿直徑：90mm
表面粗度：0.8~1.6S 流體：作動油

推薦元件

- ①③耐磨環 (DURATEX) B1-50705-1600-A-D900
- ②AQ SEAL S56103-1600-46
- ④⑤耐磨環 (ORKOT) BB-50704-0900-C-TLG
- ⑥⑦單動油封 (STEP-SEAL) S55013-0900-46K
- ⑧刮塵封圈 (EXCLUDER) DA17-0900-N90
- ⑨⑩⑪O型環及背托環

用途——油壓斷路器

油壓斷路器之用途更嚴苛，必須考慮到速度、頻率及振動。為滿足這些條件，必須使用特殊設計之單動油封 (STEP SEAL) 及刮塵封圈 (EXCLUDER) 並對硬體部份略做修正。克普典公司歡迎客戶提出其特定用途之封圈系統的需求。(參照圖14)

使用例條件

壓力：PEAK壓200kgf/cm²
速度：最高10m/s 頻率：50Hz
缸桿徑：130/135mm

推薦元件

- ①複動油封 (GLYD RING) S55043-1300-46X
- ②③特殊單動油封 (STEP-SEAL)
- ④特殊單動油封 (STEP-SEAL)
- ⑤特殊刮塵封圈 (EXCLUDER)



図13

クレーン用シリンダ

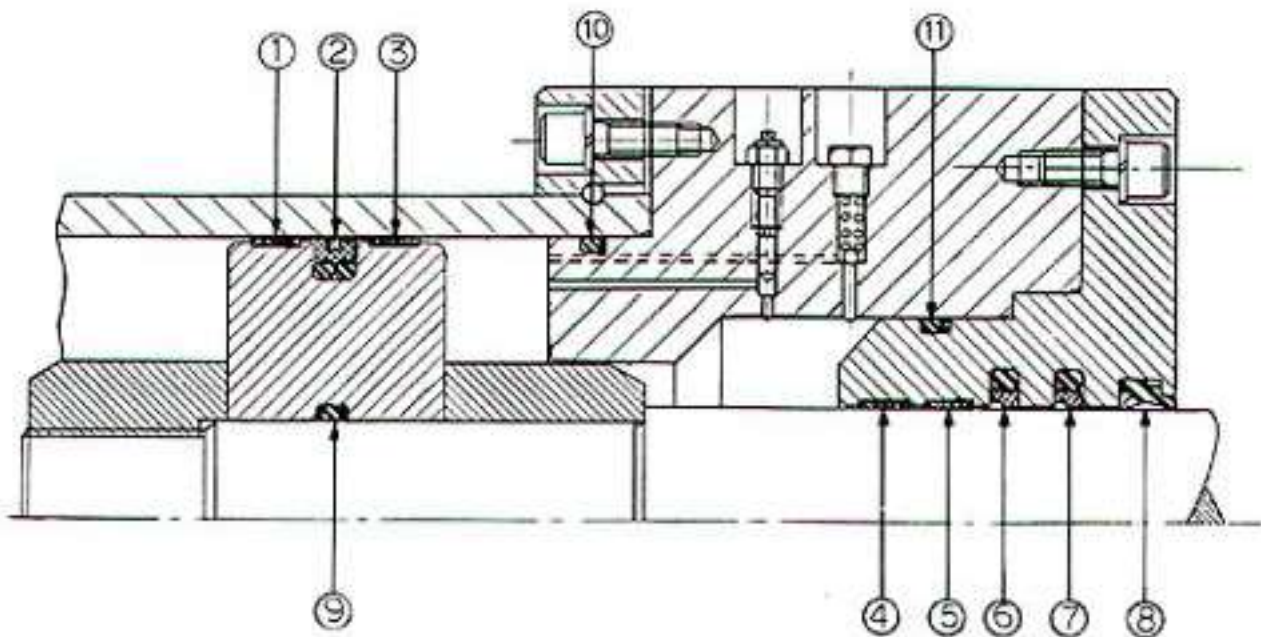

図14

油圧ブレーカ

用途——旋轉連軸器

旋轉連軸器是為使回路能夠旋轉或擺動而用的。舉例言之，掘削機所使用的多頭連軸器屬於此類，其油壓系統是經由此連軸器在機械做旋轉運動時，活塞也能動作。連桿複動封圈 (rod GLYD ring) 是為旋轉連軸器而開發的。它在旋轉之際，將高壓與低壓封隔，具有低扭力性能及簡單的硬體設計的優點。一般置於環狀溝內，能夠封隔兩側的壓力。

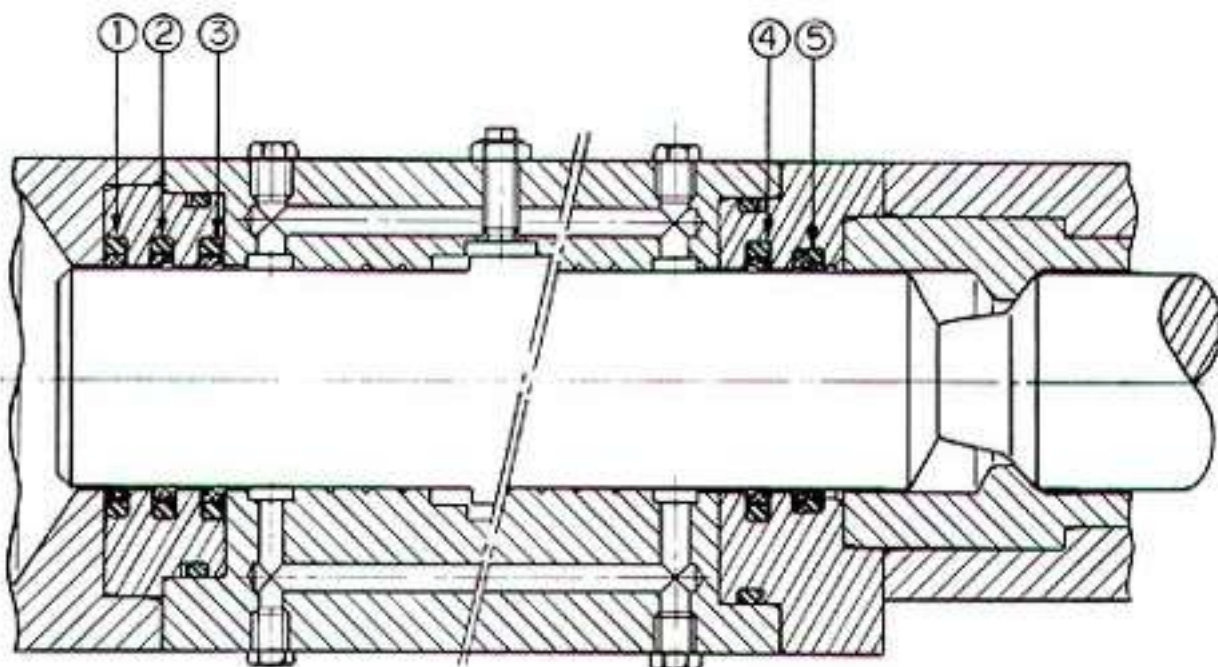
使用例條件

壓力：75kgf/cm² 流體：作動油 運動：搖動
表面速度：0.1m/s 連桿徑：130mm 表面粗度：0.8S

推薦元件

- ①④ 旋轉式複動油封 (ROE GLYD RING) S56132-1300-10
- ⑤ 旋轉隔離封圈 (VARI-SEAL ROTARY) S59117-1200-10S



圖15 回轉継手

用途——流體分配器

使用旋轉隔離封圈 (Vari-seal rotary) 的流體分配器與使用連桿複動封圈 (rod GLYD ring) 的旋轉連桿具有相同的機能，只是它的速度較快。使用旋轉隔離封圈的流體分配器可以用於最新的冷卻液及潤滑油系統。

使用例條件

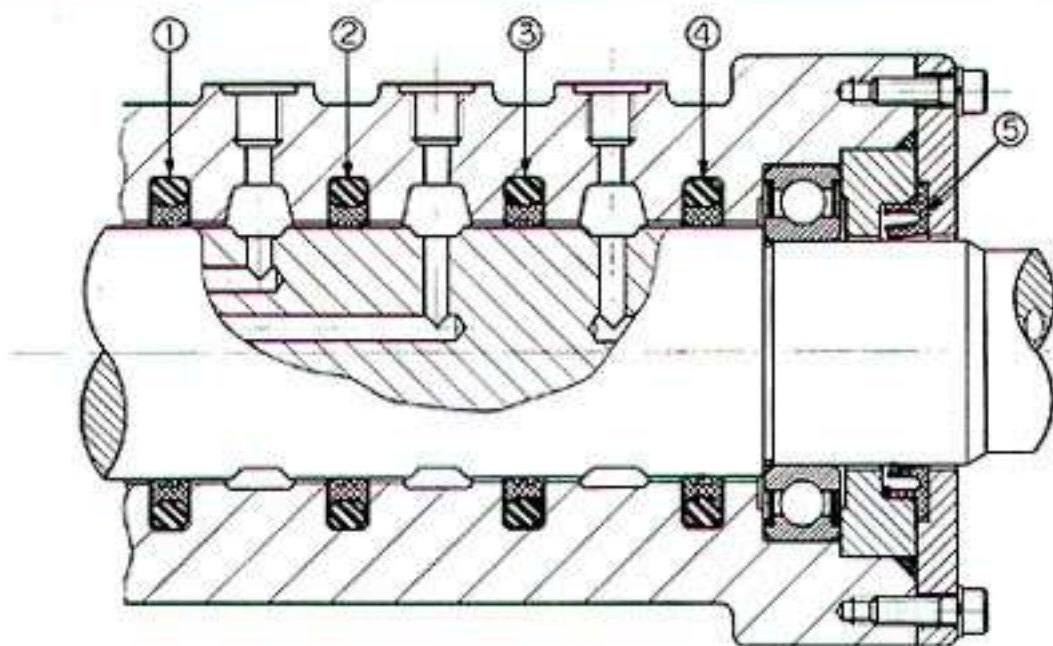
壓力：0~10kgf/cm² 轉數：700rpm 桿徑：110mm

表面速度：4m/s 表面粗糙度：Ra=0.15 硬度：HRC 55

連桿材料：淬火鋼 流體：油

推薦元件

①②③旋轉隔離封圈 (VARI-SEAL ROTARY) S591
17-1100-105



圖16 流體分配器

用途——閥類

閥類用於各種媒體，並在各種條件下使用。其中有使用於高溫蒸汽、極低溫液體、二氧化碳、腐蝕性液體及氣體等媒體者。在這種媒體用的閥類中，要保證其封圈的性能宜採用固定性隔離封圈。固定性隔離封圈是由Tuncon或Tuncite封圈套及裝在其上之不銹鋼或耐蝕性鍍合金所製的彈簧所組成。由於其材料之組合及優異的設計，固定性隔離封圈在 $-250^{\circ}\text{C}\sim-260^{\circ}\text{C}$ 之範圍內能夠用於大部分的媒體。

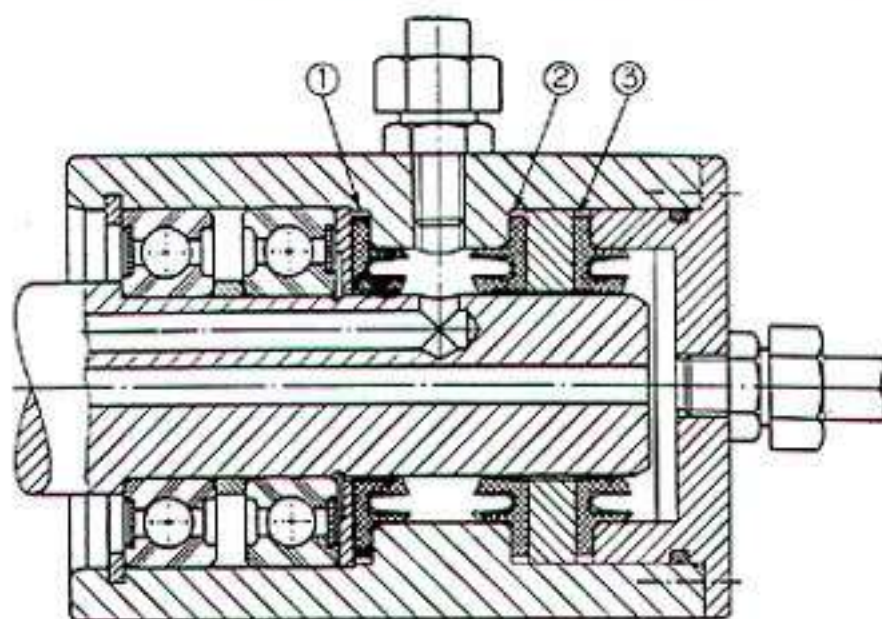
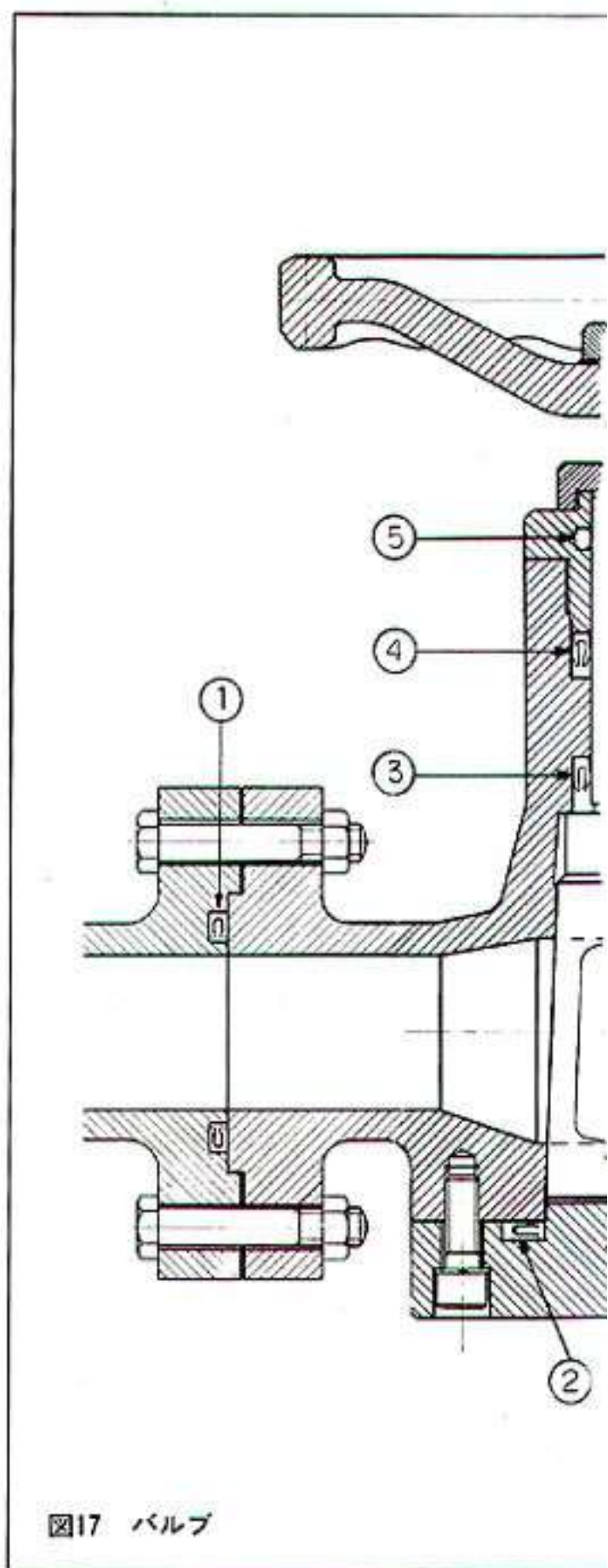

使用例條件

壓力：最高320kgf/cm² 溫度：最高200°C

運動：低速度回轉 接觸面材料：鑄鐵 不銹鋼：
青銅

推薦元件

①表面隔離封圈 (VARI-SEAL FACE) S55692-07
00-1S

②表面隔離封圈 (VARI-SEAL FACE) S55692-08
00-1S

③④靜隔離封圈 (VARI-SEAL STATIC) S59065-
0300-1S

⑤O型環

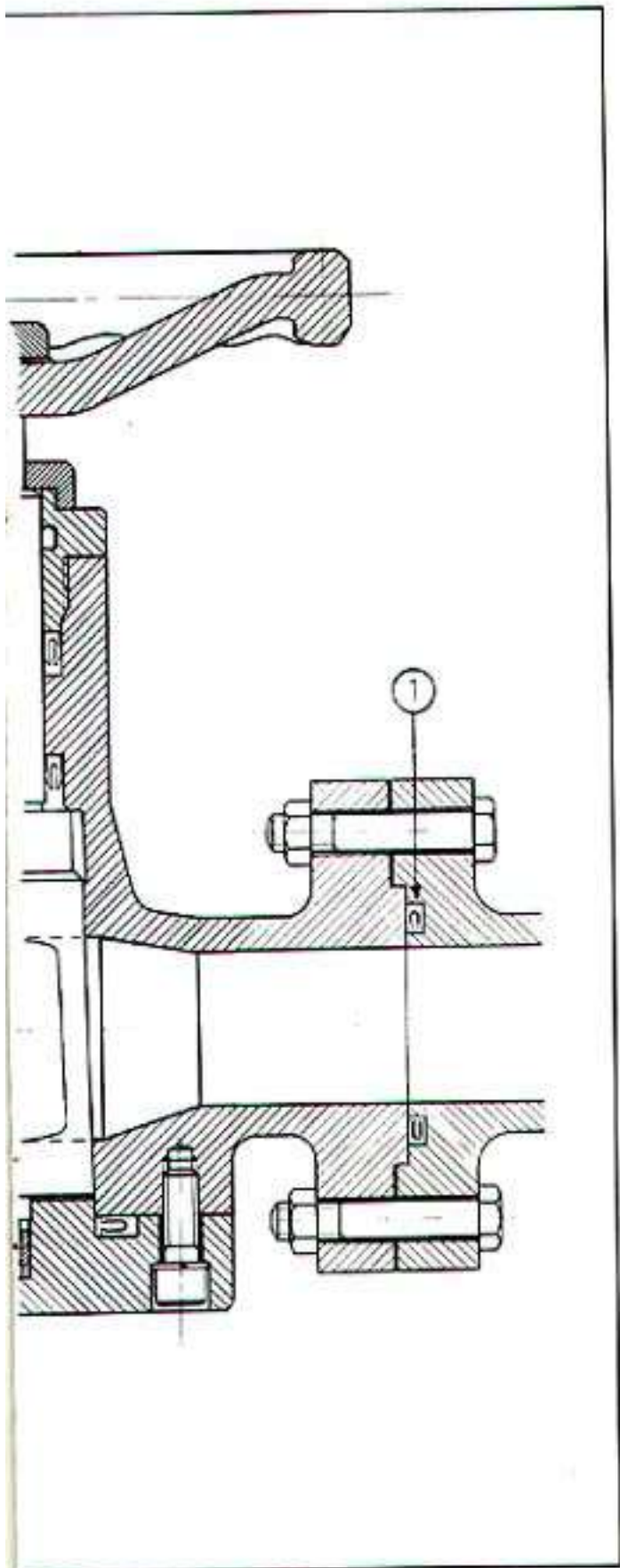

用途——研究室用之真空裝置

如圖18的研究室之真空裝置，其真空室的溫度變化很大，被檢的零件由於在試驗中迴轉或往復運動必須要能耐廣泛的溫度範圍及密封效果極佳的封圈系統，這時你必須採用S&C滑動封圈（slide ring）及隔離封圈（VARI-seal）。

使用例條件

溫度：最低-170℃ 最高+250℃

壓力：各種真空度 運動：往復及迴轉運動

桿徑：25mm 表面粗度：Ra=0.05μm

推薦元件

①耐磨環（SLIDE RING）S55856-0250-10A

②隔離封圈（VARI-SEAL）S59065-0250-1S

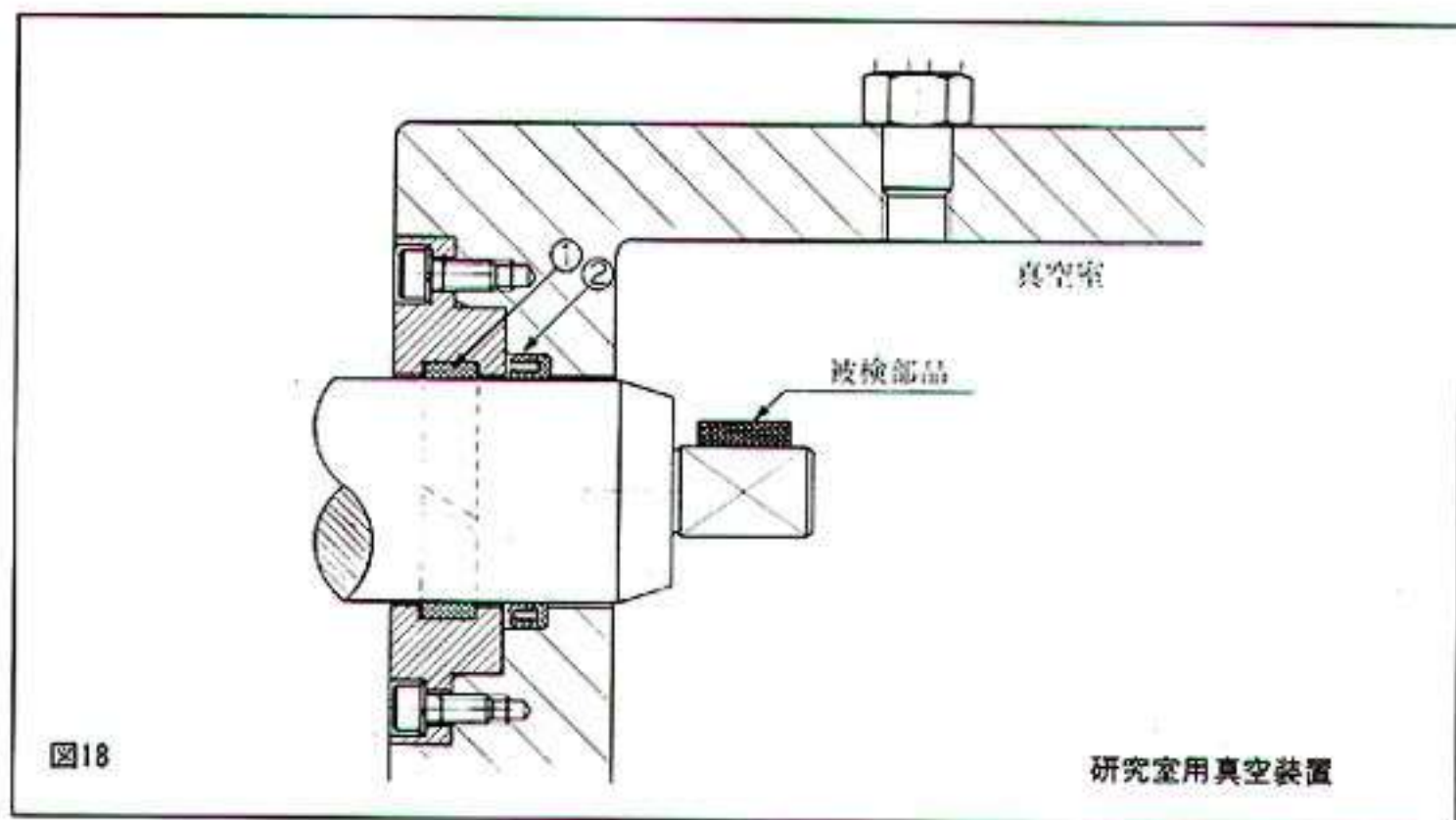

用途——避震器 (Shock absorber)

避震器是對於汽車及機車之操縱性及快適性有極大關係的重要零件之一。

複合滑動封圈在傳統的避震器及高級積桿系統中皆使用。由封圈系統及承重系統組合的複合滑動封圈由於壽命長故能保持避震器的最高性能。

複合滑動封圈 (combi-slide ring) 之特徵是

- 低摩擦
- 有效的封密效果及高效率
- 無金屬類之接觸
- 有效壽命長
- 動作無聲

複合滑動封圈是配合個別用途而設計的，客戶如有吩咐當即提供更詳細之資料及建議。

1. 特殊耐磨環 (SLIDE RING)
2. 單動油封 (STEP-SEAL) S55013-0200-46K
3. DA 刮塵油封 (DA EXCLUDER) DA17-0200-S90

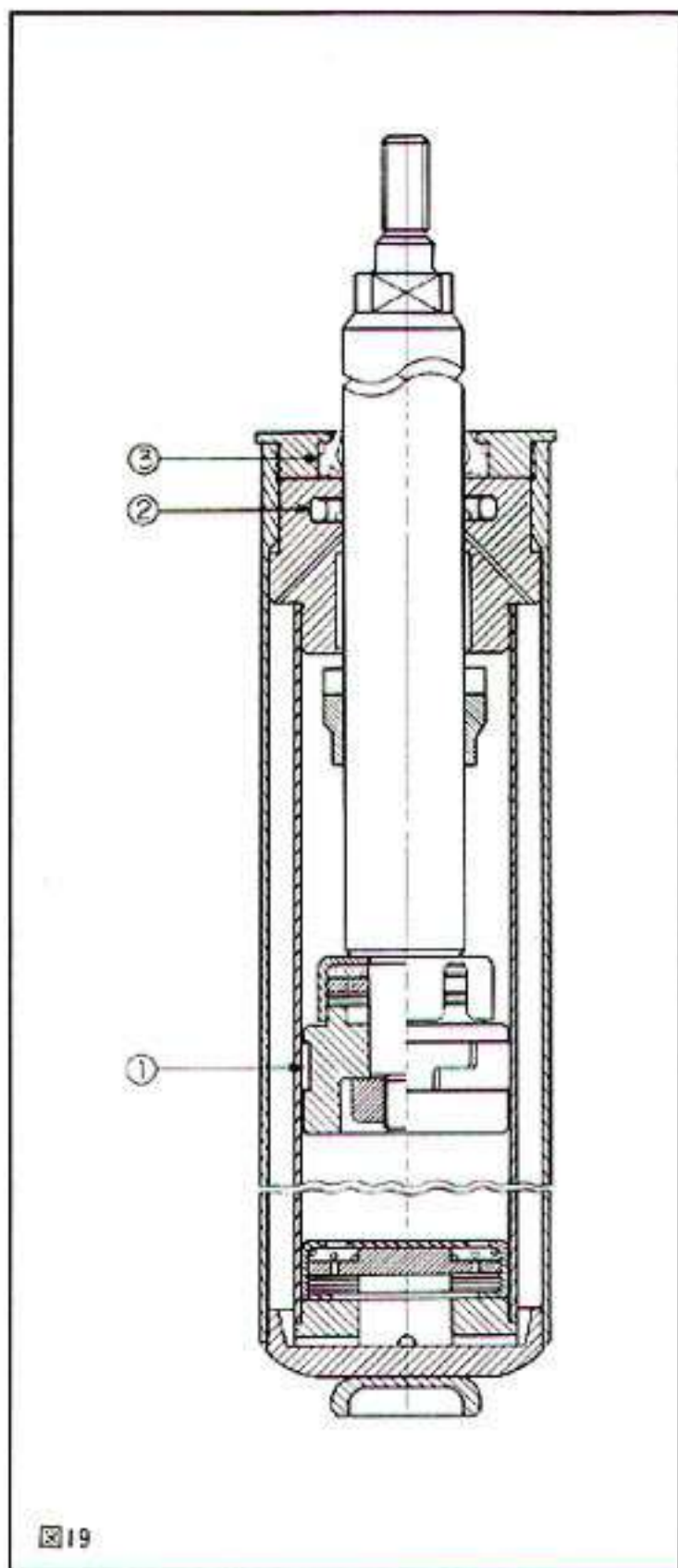

製品用途速見表

下表為Shamban & Captain製品於各種不同用途所適用情形之概略表示。

製 品 用 品	PISTON CYLINDER	ROD CYLINDER	往 復 運 動	回 轉 運 動	空 壓	油 壓	化 學 藥 品	低 溫 (低於150°C)	高 溫 (150~260°C)	高 壓 (400~800kgf/cm ²)	超 高 壓 (高於800kgf/cm ²)
複動紅油封(GLYD RING)	1	2	1			1				1	
輕型複動紅油封(GLYD RING LIGHT-DUTY)	1	1	1		1**	2		2			
AQ封圈(AQ SEAL)	1		1•		1	1					
單動紅油封(step seal)		1	1			1				1	
旋轉式複動紅油封(ROTARY GLYD RING)	2	1	2	1•	2	1					
刮塵封圈(EXCLUDER)		1	1		1	1					
DA刮塵封圈(EXCLUDER DA)		1	1•			1					
表面隔離封圈(VARI-SEAL)	1	1	1	2	1	2	1	1	1		
旋轉式表面隔封圈(VAI-SEAL ROTARY)	2	1	2	1	1	1	1	1	1		
特殊設計製品	1	1	1	1	1	1	1	1	1	1	1

* 1" 表適用性極佳。

* 2" 表適用性良好。

* •" 表速度為中程度的場合。

* **" 表其體是乾燥空氣的結構下。



■ General

Busak+Shamban researched and developed, using finite element analysis programs for modeling and laboratory/field testing, a type of seal to fit the requirement for exact positioning of hydraulic cylinders under load. The development objective was to keep the familiar properties of the classic elastomer-energized plastic seal, but to improve its extrusion resistance.

The result is the Turcon® Glyd Ring® T, a patented seal (Patent No. 41 40833). It retains a simple and compact construction. Yet, by means of specific profiling, it brings about a substantial improvement in leakage behavior. This behavior applies equally where there are larger gaps between the piston and cylinder wall.

Description

Both lateral profile flanks are included so that the seal profile tapers toward the seal surface. The profile can thus retain the robust and compact form typical of piston seals without losing any of the flexibility required to achieve a pressure-related maximum compression.

The edge angle created by the special Turcon® Glyd Ring® T cross sectional form permits an additional degree of freedom and enables a slight tilting movement of the seal. The maximum compression is thus always shifted toward the area of the seal edge directly exposed to the pressure. (See Figure 1) On the low-pressure edge of the seal, on the other hand, the Turcon® Glyd Ring® T exhibits only zones with neutral strains without compressive or shearing loads, thus effectively reducing the danger of gap extrusion.

Functional Principle

Through a build up of pressure, the ring is pressed against the side of the groove. Due to the sloping sides, the result is a "tilting" of the seal ring. The maximum compression then, is shifted toward the area of the seal edge directly exposed to the pressure.

Advantages

- Very good static leak-tightness
- Larger extrusion gaps possible (approximately 50 to 100%), depending on the application. Thus, reduced machining costs
- Due to the larger extrusion gap, safe use even with soiled media
- Low friction, no stick-slip effect
- Simple groove design, one piece piston possible
- Installation grooves to DIN/ISO 7425/1
- Adaptable to the operating conditions due to a wide range of possible materials
- Suitable for new environmentally safe hydraulic fluids (bio oils)
- Available for all cylinder diameters up to 2500mm (100 inches)

Technical Data

Operating Pressure:	up to 80MPa (11,600 psi) (for pressure above 32MPa, consult factory)
Speed:	up to 15 m/s reciprocating (up to 50 ft/s)
Temperature:	-54°C to +200°C (- 65°F to +392°F) (depending on O-Ring compound)
Compatible Media:	mineral oil-based hydraulic fluids, environmentally safe hydraulic fluids (bio-oils), and others, depending on the seal material

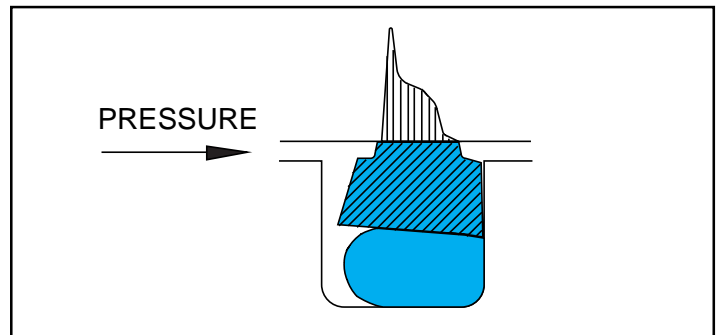

Figure 1 Turcon® Glyd Ring® T load distribution profile



Turcon® Glyd Ring® T Dimensional Data

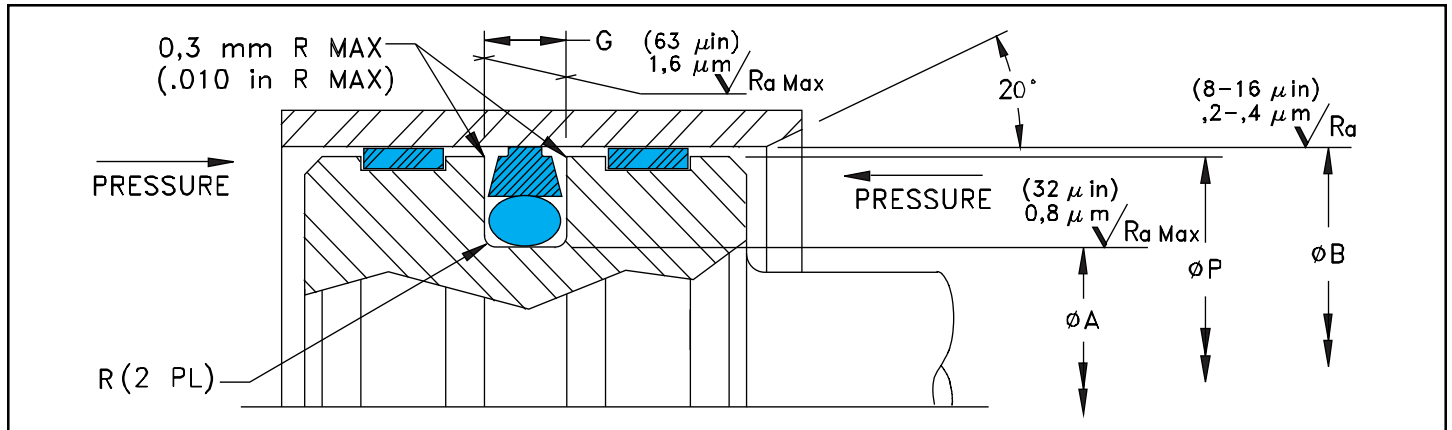

Table 2 Turcon® Glyd Ring® T Ordering Information (Metric)

Bore Dia. B H9	Groove Dia. A h9	Groove Width G+0,2	Minimum Piston Diameter P			Radius R (Max)	O-Ring Dash No.	Turcon® Glyd Ring® T Turcon® T46
			0-10 MPa	10-20 MPa	20-32 MPa			Part No.
14,0	9,1	2,2	13,04	13,44	13,64	0,4	012	PT0000140-T46
15,0	7,5	3,2	13,84	14,24	14,64	0,6	109	PT0100150-T46
18,0	10,5	3,2	16,84	17,24	17,64	0,6	111	PT0100180-T46
20,0	12,5	3,2	18,85	19,25	19,65	0,6	112	PT0100200-T46
22,0	14,5	3,2	20,85	21,25	21,65	0,6	113	PT0100220-T46
25,0	17,5	3,2	23,85	24,25	24,65	0,6	115	PT0100250-T46
28,0	20,5	3,2	26,85	27,25	27,65	0,6	117	PT0100280-T46
30,0	22,5	3,2	28,85	29,25	29,65	0,6	118	PT0100300-T46
32,0	24,5	3,2	30,86	31,26	31,66	0,6	119	PT0100320-T46
35,0	27,5	3,2	33,86	34,26	34,66	0,6	121	PT0100350-T46
36,0	28,5	3,2	34,86	35,26	35,66	0,6	122	PT0100360-T46
40,0	29,0	4,2	38,86	39,26	39,66	0,8	216	PT0200400-T46
42,0	31,0	4,2	40,86	41,26	41,66	0,8	217	PT0200420-T46
45,0	34,0	4,2	43,86	44,26	44,66	0,8	219	PT0200450-T46
48,0	37,0	4,2	46,86	47,26	47,66	0,8	221	PT0200480-T46
50,0	39,0	4,2	48,86	49,26	49,66	0,8	222	PT0200500-T46
52,0	41,0	4,2	50,87	51,27	51,67	0,8	223	PT0200520-T46
55,0	44,0	4,2	53,87	54,27	54,67	0,8	224	PT0200550-T46
56,0	45,0	4,2	54,87	55,27	55,67	0,8	224	PT0200560-T46
60,0	49,0	4,2	58,87	59,27	59,67	0,8	225	PT0200600-T46
63,0	52,0	4,2	61,87	62,27	62,67	0,8	226	PT0200630-T46
65,0	54,0	4,2	63,87	64,27	64,67	0,8	227	PT0200650-T46
70,0	59,0	4,2	68,87	69,27	69,67	0,8	228	PT0200700-T46
75,0	64,0	4,2	73,87	74,27	74,67	0,8	230	PT0200750-T46
80,0	64,5	6,3	78,47	79,07	79,47	1,2	333	PT0300800-T46
85,0	69,5	6,3	83,49	84,09	84,49	1,2	335	PT0300850-T46
90,0	74,5	6,3	88,49	89,09	89,49	1,2	336	PT0300900-T46
95,0	79,5	6,3	93,49	94,09	94,49	1,2	338	PT0300950-T46
100,0	84,5	6,3	98,49	99,09	99,49	1,2	339	PT0301000-T46

Bold indicates grooves per ISO 7425/1



Table 2 Turcon® Glyd Ring® T Ordering Information (Metric-Continued)

Bore Dia. B H9	Groove Dia. A h9	Groove Width G+0,2	Minimum Piston Diameter P			Radius R (Max)	O-Ring Dash No.	Turcon® Glyd Ring® T Turcon® T46
			0-10 MPa	10-20 MPa	20-32 MPa			Part No. No.
105,0	89,5	6,3	103,49	104,09	104,49	1,2	341	PT0301050-T46
110,0	94,5	6,3	108,49	109,09	109,49	1,2	342	PT0301100-T46
115,0	99,5	6,3	113,49	114,09	114,49	1,2	344	PT0301150-T46
120,0	104,5	6,3	118,49	119,09	119,49	1,2	346	PT0301200-T46
125,0	109,5	6,3	123,50	124,10	124,50	1,2	347	PT0301250-T46
130,0	114,5	6,3	128,50	129,10	129,50	1,2	349	PT0301300-T46
135,0	114,0	8,1	133,50	134,10	134,50	1,5	425	PT0401350-T46
140,0	119,0	8,1	138,50	139,10	139,50	1,5	426	PT0401400-T46
150,0	129,0	8,1	148,50	149,10	149,50	1,5	429	PT0401500-T46
160,0	139,0	8,1	158,50	159,10	159,50	1,5	432	PT0401600-T46
170,0	149,0	8,1	168,50	169,10	169,50	1,5	435	PT0401700-T46
180,0	159,0	8,1	178,50	179,10	179,50	1,5	438	PT0401800-T46
190,0	169,0	8,1	188,52	189,12	189,52	1,5	439	PT0401900-T46
200,0	179,0	8,1	198,52	199,12	199,52	1,5	441	PT0402000-T46
210,0	189,0	8,1	208,52	209,12	209,52	1,5	442	PT0402100-T46
220,0	199,0	8,1	218,52	219,12	219,52	1,5	444	PT0402200-T46
230,0	209,0	8,1	228,52	229,12	229,52	1,5	445	PT0402300-T46
240,0	219,0	8,1	238,52	239,12	239,52	1,5	446	PT0402400-T46
250,0	229,0	8,1	248,52	249,12	249,52	1,5	447	PT0402500-T46
280,0	259,0	8,1	278,53	279,13	279,53	1,5	449	PT0402800-T46
300,0	279,0	8,1	298,53	299,13	299,53	1,5	451	PT0403000-T46
320,0	299,0	8,1	318,54	319,14	319,54	1,5	452	PT0403200-T46
350,0	325,5	8,1	348,34	349,14	349,34	1,5	454	PT0803500-T46
400,0	375,5	8,1	398,34	399,14	399,34	1,5	458	PT0804000-T46
420,0	395,5	8,1	418,36	419,16	419,36	1,5	460	PT0804200-T46
450,0	425,5	8,1	448,36	449,16	449,36	1,5	462	PT0804500-T46
480,0	455,5	8,1	478,36	479,16	479,36	1,5	464	PT0804800-T46
500,0	475,5	8,1	498,36	499,16	499,36	1,5	466	PT0805000-T46
520,0	495,5	8,1	518,37	518,77	519,17	1,5	468	PT0805200-T46
530,0	505,5	8,1	528,37	528,77	529,17	1,5	469	PT0805300-T46
550,0	525,5	8,1	548,37	548,77	549,17	1,5	469	PT0805500-T46
560,0	535,5	8,1	558,37	558,77	559,17	1,5	470	PT0805600-T46
580,0	555,5	8,1	578,37	578,77	579,17	1,5	471	PT0805800-T46
600,0	575,5	8,1	598,37	598,77	599,17	1,5	471	PT0806000-T46
610,0	585,5	8,1	608,37	608,77	609,17	1,5	472	PT0806100-T46
630,0	605,5	8,1	628,39	628,79	629,19	1,5	473	PT0806300-T46
650,0	625,5	8,1	648,39	648,79	649,19	1,5	473	PT0806500-T46
660,0	635,5	8,1	658,39	658,79	659,19	1,5	474	PT0806600-T46
680,0	655,5	8,1	678,39	678,79	679,19	1,5	475	PT0806800-T46
700,0	672,0	9,5	698,19	698,59	698,99	2,7	8,4x670	PT0507000-T46
750,0	722,0	9,5	748,19	748,59	748,99	2,7	8,4x715	PT0507500-T46
800,0	772,0	9,5	798,21	798,61	799,01	2,7	8,4x760	PT0508000-T46
900,0	872,0	9,5	898,21	898,61	899,01	2,7	8,4x865	PT0509000-T46
1000,0	962,0	13,8	997,82	998,42	998,82	3,2	12x961	PT06X1000-T46

Bold indicates grooves per ISO 7425/1

Other dimensions and all intermediate sizes up to 2500mm diameter can be supplied.



Table 3 Turcon® Glyd Ring® T Ordering Information (Imperial)

Bore Dia.	Groove Dia.	Groove Width	Minimum Piston Diameter P (psi)			Radius	O-Ring	Turcon® Glyd Ring® T
			1500	3000	4500			Turcon® T46
B H9	A h9	G+.008				R (Max)	Dash No.	Part No.
1.000	.705	.126	.954	.970	.986	.025	115	PT1101000-T46
1.125	.830	.126	1.079	1.095	1.111	.025	117	PT1101125-T46
1.250	.955	.126	1.204	1.220	1.236	.025	119	PT1101250-T46
1.375	1.080	.126	1.329	1.345	1.361	.025	121	PT1101375-T46
1.500	1.205	.126	1.454	1.470	1.486	.025	123	PT1101500-T46
1.750	1.317	.165	1.704	1.720	1.736	.025	219	PT1201750-T46
2.000	1.567	.165	1.955	1.971	1.987	.025	222	PT1202000-T46
2.250	1.817	.165	2.205	2.221	2.237	.025	224	PT1202250-T46
2.500	2.067	.165	2.455	2.471	2.487	.025	226	PT1202500-T46
2.750	2.317	.165	2.705	2.721	2.737	.025	228	PT1202750-T46
3.000	2.567	.165	2.955	2.971	2.987	.025	230	PT1203000-T46
3.250	2.640	.248	3.191	3.213	3.229	.035	334	PT1303250-T46
3.500	2.890	.248	3.441	3.463	3.479	.035	336	PT1303500-T46
3.750	3.140	.248	3.691	3.713	3.729	.035	338	PT1303750-T46
4.000	3.390	.248	3.941	3.963	3.979	.035	340	PT1304000-T46
4.500	3.890	.248	4.441	4.463	4.479	.035	344	PT1304500-T46
5.000	4.390	.248	4.942	4.964	4.980	.035	348	PT1305000-T46
5.500	4.673	.319	5.442	5.464	5.480	.035	426	PT1405500-T46
6.000	5.173	.319	5.942	5.964	5.980	.035	430	PT1406000-T46
6.500	5.673	.319	6.442	6.464	6.480	.035	434	PT1406500-T46
7.000	6.173	.319	6.942	6.964	6.980	.035	437	PT1407000-T46
7.500	6.673	.319	7.443	7.465	7.481	.035	439	PT1407500-T46
8.000	7.173	.319	7.943	7.965	7.981	.035	441	PT1408000-T46
8.500	7.673	.319	8.443	8.465	8.481	.035	443	PT1408500-T46
9.000	8.173	.319	8.943	8.965	8.981	.035	445	PT1409000-T46
9.500	8.673	.319	9.443	9.465	9.481	.035	446	PT1409500-T46
10.000	9.173	.319	9.943	9.965	9.981	.035	447	PT1410000-T46
10.500	9.673	.319	10.443	10.465	10.481	.035	448	PT1410500-T46
11.000	10.173	.319	10.943	10.965	10.981	.035	449	PT1411000-T46
11.500	10.673	.319	11.443	11.465	11.481	.035	450	PT1411500-T46
12.000	11.173	.319	11.943	11.965	11.981	.035	451	PT1412000-T46
12.500	11.673	.319	12.444	12.466	12.482	.035	452	PT1412500-T46
13.000	12.035	.319	12.936	12.966	12.974	.035	453	PT1513000-T46
13.500	12.535	.319	13.436	13.466	13.474	.035	454	PT1513500-T46
14.000	13.035	.319	13.936	13.966	13.974	.035	455	PT1514000-T46

Bold print indicates BusakShamban Preferred Design sizes.



Table 3 Turcon® Glyd Ring® T Ordering Information (Imperial- Continued)

Bore Dia. B H9	Groove Dia. A h9	Groove Width G+.008	Minimum Piston Diameter P (psi)			Radius R (Max)	O-Ring Dash No.	Turcon® Glyd Ring® T Turcon® T46
			1500	3000	4500			Part No.
14.500	13.535	.319	14.436	14.466	14.474	.035	456	PT1514500-T46
15.000	14.035	.319	14.936	14.966	14.974	.035	457	PT1515000-T46
15.500	14.535	.319	15.436	15.466	15.474	.035	458	PT1515500-T46
16.000	15.035	.319	15.936	15.966	15.974	.035	459	PT1516000-T46
16.500	15.535	.319	16.436	16.466	16.474	.035	460	PT1516500-T46
17.000	16.035	.319	16.936	16.966	16.974	.035	461	PT1517000-T46
17.500	16.535	.319	17.436	17.466	17.474	.035	462	PT1517500-T46
18.000	17.035	.319	17.936	17.966	17.974	.035	463	PT1518000-T46
18.500	17.535	.319	18.436	18.466	18.474	.035	464	PT1518500-T46
19.000	18.035	.319	18.936	18.966	18.974	.035	465	PT1519000-T46
19.500	18.535	.319	19.436	19.466	19.474	.035	466	PT1519500-T46
20.000	19.035	.319	19.936	19.966	19.974	.035	467	PT1520000-T46

Bold print indicates BusakShamban Preferred Design sizes.

Ordering Example

Turcon® Glyd Ring® T, standard application, series PT03

Bore Diameter: B = 80.0 mm
 Part No.: PT0300800-T46 (from Table 2)

Select the material from Table 1, page 2. The corresponding code numbers are appended to the Part No. Together they form the Order Number.

Order O-Ring separately.

The matching O-Ring may have either larger or smaller ID than the groove diameter on the piston. However, the difference shall not affect the performance and reliability of the seal once the Turcon® Glyd Ring® T is properly installed.

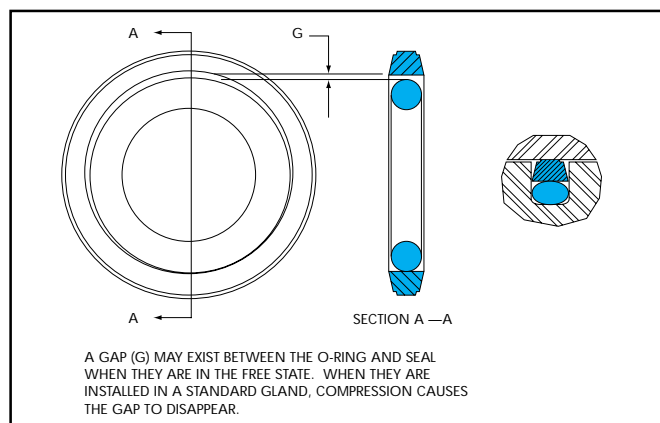
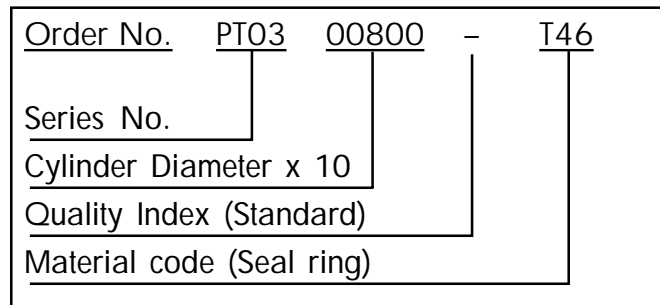



General

The D-A-S Compact Seal is a double-acting piston seal.

Compact seals are multipart sealing systems which generally consist of an elastic rubber ring, and additional back-up and guiding elements. The design provides a compact seal and guide combination for a closed installation groove.

Description

The D-A-S Compact Seal is comprised of an elastomeric profile seal ring, two back-up rings and two wear rings. (See Figure 2) The actual sealing element is located in the center of the seal, and one back-up ring and one wear ring are positioned on each side. The center seal or profile seal ring, seals in both the static and dynamic range while the back-up rings prevent extrusion into the seal gap. The function of the wear rings is to guide the piston in the cylinder barrel and to absorb transverse forces.

Advantages

- Closed groove and one-piece piston
- Short overall length of the piston
- One groove for seal and guidance
- Low cost piston production
- Inexpensive seal and guide element
- High resistance to gap extrusion
- No twisting or turning of the elastic sealing element
- Low leakage values
- Simple snap-on installation with scarf cut back-up and wear rings

Fields of Application

The D-A-S Compact Seal is used as a sealing element for pistons and hydraulic cylinders for reciprocating motion, such as light duty earth moving machines, cranes, fork lift trucks, hydraulic tailgates, agricultural machines, etc.

Technical Data

Pressure:	up to 25 MPa (3600 psi); briefly up to 35 MPa (5145 psi)
Speed:	maximum 0,5 m/s (1.5 ft/s) reciprocating
Temperature:	-30°C to +110°C (-22°F to +230°F)
Media:	mineral oil-based hydraulic fluids, flame retardant hydraulic fluids, environmentally safe hydraulic fluids (bio-oils), water, and others depending on the material

Method of Operation

Three sealing lips are located around the outside diameter. The center sealing lip is thicker and forms the main seal, while the two outer sealing lips act as additional seals. On the inside diameter (static seal), the contact surface at the groove diameter is relatively wide. One back-up ring is positioned on each side to support it against elastomer extrusion. The back-up rings are stepped to prevent rotation of the sealing element during operation.

Material

The D-A-S Compact Seal is available in the following designs:

Profile Seal:	Acrylonitrile butadiene rubber (NBR)
Back-up Ring:	Turquoise color, polyester elastomer with additives
Wear Rings:	Glass fiber-reinforced thermoplastic polymer

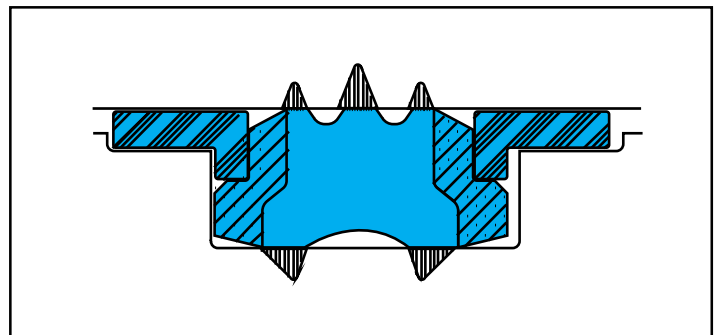

Figure 2 D-A-S Compact Seal load distribution profile



D-A-S Compact Seal Dimensional Data

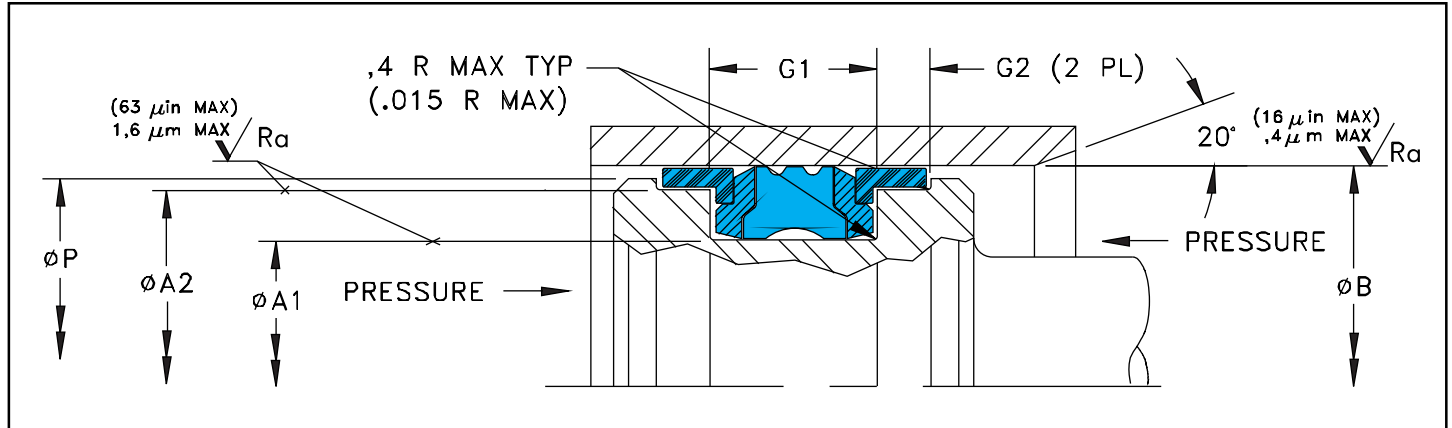

Table 4 D-A-S Compact Seal Ordering Information (Metric)

Bore Dia. B H9	Groove Diameter		Groove Width		Piston Dia. P h11	D-A-S Compact Seal Part No.
	A1 h9	A2 h9	G1+0,2	G2 +0,1		
20,0	11,0	17,00	13,5	2,10	19,0	PCB0N0200-NCRO
25,0	15,0	21,00	12,0	4,00	23,0	PCB0D0250-NCRO
30,0	21,0	27,00	13,5	2,10	29,0	PCB0N0300-NCRO
35,0	25,0	31,40	16,4	6,35	33,5	PCB1A0350-NCRO
40,0	30,0	35,40	16,4	6,35	38,5	PCB3A0400-NCRO
45,0	31,0	41,00	15,5	2,60	44,0	PCB1A0450-NCRO
50,0	34,0	46,00	20,5	3,10	49,0	PCB0B0500-NCRO
55,0	39,0	50,36	18,4	6,35	53,5	PCB1A0550-NCRO
60,0	44,0	56,00	20,5	3,10	59,0	PCB0B0600-NCRO
63,0	47,0	58,40	18,4	6,35	61,5	PCB1A0630-NCRO
65,0	50,0	60,40	18,4	6,35	63,5	PCB1A0650-NCRO
70,0	50,0	64,20	22,4	6,35	68,3	PCB0A0700-NCRO
75,0	59,0	71,00	20,5	3,10	74,0	PCB1A0750-NCRO
80,0	62,0	76,00	22,5	3,60	79,0	PCB1A0800-NCRO
85,0	65,0	79,15	22,4	6,35	83,3	PCB0A0850-NCRO
90,0	72,0	86,00	22,5	3,60	89,0	PCB1A0900-NCRO
95,0	75,0	89,15	22,4	6,35	93,0	PCB0A0950-NCRO
100,0	82,0	96,00	22,5	3,60	99,0	PCB1A1000-NCRO
105,0	80,0	98,10	22,4	6,35	103,0	PCB0A1050-NCRO
110,0	92,0	106,00	22,5	3,60	109,0	PCB1A1100-NCRO



Table 4 D-A-S Compact Seal Ordering Information (Metric - Continued)

Bore Dia. B H9	Groove Diameter		Groove Width		Piston Dia. P h11	D-A-S Compact Seal Part No.
	A1 h9	A2 h9	G1+0,2	G2 +0,1		
115,0	90,0	108,10	22,4	6,35	113,0	PCBOA1150-NCRO
120,0	95,0	113,10	22,4	6,35	118,0	PCBOA1200-NCRO
125,0	103,0	121,00	26,5	5,10	124,0	PCB1A1250-NCRO
130,0	105,0	123,10	25,4	6,35	128,0	PCBOB1300-NCRO
135,0	110,0	127,60	25,4	9,50	132,5	PCB1A1350-NCRO
140,0	118,0	136,00	26,5	5,10	139,0	PCB2A1400-NCRO
145,0	120,0	137,60	25,4	9,50	142,5	PCB1A1450-NCRO
150,0	125,0	142,60	25,4	9,50	147,5	PCB1A1500-NCRO
155,0	130,0	147,60	25,4	9,50	152,5	PCBOA1550-NCRO
160,0	130,0	153,00	25,4	6,35	157,5	PCBOA1600-NCRO
165,0	140,0	157,60	25,4	9,50	162,5	PCBOA1650-NCRO
170,0	148,0	166,00	26,5	5,10	169,0	PCB1A1700-NCRO
175,0	150,0	166,70	25,4	12,70	172,1	PCBOA1750-NCRO
180,0	155,0	171,70	25,4	12,70	177,0	PCB1A1800-NCRO
185,0	160,0	176,70	25,4	12,70	182,0	PCBOA1850-NCRO
190,0	165,0	181,70	25,4	12,70	187,0	PCBOA1900-NCRO
195,0	170,0	186,70	25,4	12,70	192,0	PCBOA1950-NCRO
200,0	175,0	191,60	25,4	12,70	197,0	PCBOA2000-NCRO
210,0	185,0	201,60	25,4	12,70	207,0	PCBOA2100-NCRO
220,0	195,0	211,60	25,4	12,70	217,0	PCB1A2200-NCRO
230,0	205,0	221,60	25,4	12,70	227,0	PCBOA2300-NCRO
240,0	215,0	231,60	25,4	12,70	237,0	PCBOA2400-NCRO
250,0	225,0	241,60	25,4	12,70	247,0	PCB1A2500-NCRO

Table 5 D-A-S Compact Seal Ordering Information (Imperial)

Bore Dia. B H9	Groove Diameter		Groove Width		Piston Dia. P h11	D-A-S Compact Seal Part No.
	A1 h9	A2 h9	G1+.008	G2 +.004		
1.750	1.125	1.570	.750	.250	1.698	PCB0NB044-NCRO
2.000	1.375	1.820	.750	.250	1.948	PCB0AB050-NCRO
2.125	1.500	1.945	.750	.250	2.075	PCB0NB053-NCRO
2.375	1.750	2.194	.750	.250	2.320	PCB0AB060-NCRO
2.500	1.875	2.319	.750	.250	2.446	PCB0NB063-NCRO
2.625	2.000	2.445	.750	.250	2.570	PCB0NB066-NCRO
3.000	2.250	2.772	.937	.250	2.933	PCB0NB076-NCRO
3.500	2.750	3.271	.937	.250	3.434	PCB0NB088-NCRO



General

The Busak+Shamban Turcon® CST™ Seal is a heavy duty bidirectional piston seal commonly used in the most demanding high pressure applications. It provides excellent leakage control, extrusion and wear resistance. The CST™ Seal is especially suited for long stroke applications and accommodates larger than normal piston clearances in a wide range of fluids and extreme temperatures.

Description

Using a combination of unique seal materials and geometries, the CST™ Seal is an elastomer energized PTFE seal assembly. The CST™ Seal components are integrated in a synergistic way to provide a compact design and high performance benefits in a single piston seal groove. Its geometry affords overall stability, wear resistance, sealability, low friction and maintenance free long life.

Field and laboratory evaluations have proven the reliability of the CST™ Seal in stringent applications exceeding several million cycles.

Method of Operation

The CST™ Seal was developed by Busak+Shamban as the solution for heavy duty sealing in both high and low pressure applications. A predesigned interference gives good sealability at low pressure. When pressure increases, so does sealability, as the elastomer energized Turcon® Seal Ring converts system pressure from axial force to radial squeeze. Heavy duty HiMod® Back-up Rings are specially designed to protect the Seal Ring from extrusion, even in the most demanding cylinder applications.

Technical Data

- Pressure: up to 50 MPa (7500 psi)
- Speed: up to 1,5 m/s (5 ft/s)
- Temperature: -54°C to +120°C (-65°F to +250°F)
- Media: mineral oil-based hydraulic fluids, barely flammable hydraulic fluids, environmentally safe hydraulic fluids (bio-oils), water, and others depending on the material

Advantages

Each component of the CST™ Seal contains significant performance advantages.

Turcon® T46 Seal Ring (Bronze and Turcon® filled PTFE)

- Low friction
- Low wear rate
- Anti-extrusion by two HiMod® Back-up ring
- Interference designed into seal ring provides sealing at low pressure
- Stable rectangular seal geometry

HiMod® 60 Back-up rings (Self Lubricated Polyamide)

- Provides extrusion protection for both seal and elastomer
- Scarf cut in radial plane to eliminate nibbling of elastomer and ease installation
- Acts as a contamination ring by wiping off any internal contaminants from the bore
- High modulus material with superior toughness and extrusion resistance at elevated pressures and temperatures
- Fillet radius eliminates nibbling of elastomer
- B+S identification and "this side out" assembly mark
- General size indicated

Turel® NP Elastomer (Nitrile Rubber)

- T-Shaped elastomer prevents spiraling
- Positions Back-up Rings to prevent seal extrusion
- Provides initial energizing for effective sealability at low and high pressures
- Geometric shape provides improved stability and leakage control
- Ease of installation
- Eliminates backside leakage
- Chamfered elastomer eliminates over occupancy and reduces high loading on Back-up Rings
- "B+S" identification

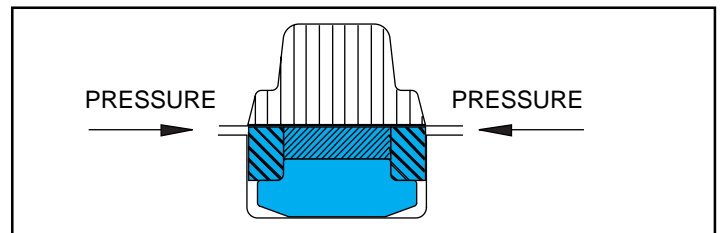

Figure 3 Turcon® CST™ Seal load distribution profile



Turcon® CST™ Seal Dimensional Data

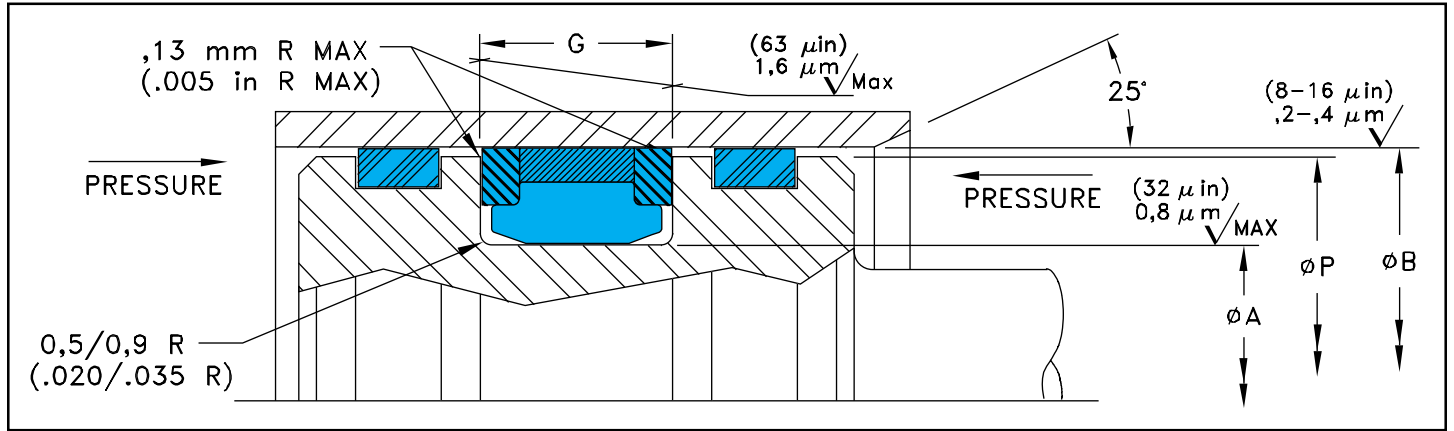

Table 6 Turcon® CST™ Ordering Information (Metric)

Bore Dia. B H9	Groove Dia. A h9	Groove Width G+0,2	Minimum Piston Diameter P		Turcon® CST™ Seal Part No.
			34,5 MPa	45,0 MPa	
50,0	36,0	9,0	49,45	49,60	PK0100500-T46NP
55,0	41,0	9,0	54,45	54,60	PK0100550-T46NP
60,0	46,0	9,0	59,46	59,61	PK0100600-T46NP
65,0	50,0	11,0	64,33	64,59	PK0200650-T46NP
70,0	55,0	11,0	69,33	69,59	PK0200700-T46NP
75,0	60,0	11,0	74,33	74,59	PK0200750-T46NP
80,0	65,0	11,0	79,33	79,59	PK0200800-T46NP
85,0	70,0	11,0	84,35	84,61	PK0200850-T46NP
90,0	75,0	11,0	89,35	89,61	PK0200900-T46NP
95,0	80,0	12,5	94,20	94,58	PK0300950-T46NP
100,0	85,0	12,5	99,20	99,58	PK0301000-T46NP
105,0	90,0	12,5	104,20	104,58	PK0301050-T46NP
110,0	95,0	12,5	109,20	109,58	PK0301100-T46NP
115,0	100,0	12,5	114,20	114,58	PK0301150-T46NP
120,0	105,0	12,5	119,20	119,58	PK0301200-T46NP
125,0	102,0	16,0	124,19	124,54	PK0401250-T46NP
130,0	107,0	16,0	129,19	129,54	PK0401300-T46NP
135,0	112,0	16,0	134,19	134,54	PK0401350-T46NP
140,0	117,0	16,0	139,19	139,54	PK0401400-T46NP
145,0	122,0	16,0	144,19	144,54	PK0401450-T46NP
150,0	127,0	16,0	149,19	149,54	PK0401500-T46NP
160,0	137,0	16,0	159,19	159,54	PK0401600-T46NP
165,0	142,0	16,0	164,19	164,54	PK0401650-T46NP
170,0	147,0	16,0	169,19	169,54	PK0401700-T46NP
180,0	157,0	16,0	179,19	179,54	PK0401800-T46NP



Table 6 Turcon® CST™ Ordering Information (Metric -Continued)

Bore Dia. B H9	Groove Dia. A h9	Groove Width G+0,2	Minimum Piston Diameter P		Turcon® CST™ Seal Part No.
			34,5 MPa	45,0 MPa	
185,0	162,0	16,0	184,21	184,56	PK0401850-T46NP
190,0	167,0	16,0	189,21	189,56	PK0401900-T46NP
200,0	177,0	16,0	199,21	199,56	PK0402000-T46NP
210,0	187,0	16,0	209,21	209,56	PK0402100-T46NP
220,0	197,0	16,0	219,21	219,56	PK0402200-T46NP
225,0	202,0	16,0	224,21	224,56	PK0402250-T46NP
230,0	207,0	16,0	229,21	229,56	PK0402300-T46NP
240,0	217,0	16,0	239,21	239,56	PK0402400-T46NP
250,0	222,0	17,5	249,15	249,51	PK0502500-T46NP
260,0	232,0	17,5	259,16	259,52	PK0502600-T46NP
270,0	242,0	17,5	269,16	269,52	PK0502700-T46NP
280,0	252,0	17,5	279,16	279,52	PK0502800-T46NP
320,0	292,0	17,5	319,17	319,53	PK0503200-T46NP

Table 7 Turcon® CST™ Seal Ordering Information (Imperial)

Bore Dia. B H9	Groove Dia. A h9	Groove Width G+.010	Minimum Piston Diameter P		Turcon® CST™ Seal Part No.
			5000 psi	6500 psi	
1.000	.627	.424	.978	.984	PK0701000-T46NP
1.250	.877	.424	1.228	1.234	PK0701250-T46NP
1.500	1.127	.424	1.478	1.484	PK0701500-T46NP
1.625	1.252	.424	1.603	1.609	PK0701625-T46NP
1.750	1.377	.424	1.728	1.734	PK0701750-T46NP
2.000	1.627	.424	1.979	1.985	PK0702000-T46NP
2.500	2.127	.424	2.479	2.485	PK0702500-T46NP
2.750	2.377	.424	2.729	2.735	PK0702750-T46NP
2.875	2.502	.424	2.854	2.860	PK0702875-T46NP
3.000	2.522	.579	2.969	2.984	PK0803000-T46NP
3.125	2.647	.579	3.094	3.109	PK0803125-T46NP
3.500	3.022	.579	3.469	3.484	PK0803500-T46NP
3.750	3.272	.579	3.719	3.734	PK0803750-T46NP
4.000	3.522	.579	3.969	3.984	PK0804000-T46NP
4.125	3.647	.579	4.094	4.109	PK0804125-T46NP
4.500	4.022	.579	4.469	4.484	PK0804500-T46NP
4.750	4.272	.579	4.719	4.734	PK0804750-T46NP
5.000	4.274	.750	4.966	4.980	PK0905000-T46NP
5.250	4.524	.750	5.216	5.230	PK0905250-T46NP
5.500	4.774	.750	5.466	5.480	PK0905500-T46NP
6.000	5.274	.750	5.966	5.980	PK0906000-T46NP
6.500	5.774	.750	6.466	6.480	PK0906500-T46NP
7.000	6.274	.750	6.966	6.980	PK0907000-T46NP
7.500	6.774	.750	7.467	7.481	PK0907500-T46NP
8.000	7.274	.750	7.967	7.981	PK0908000-T46NP



Table 7 Turcon® CST™ Seal Ordering Information (Imperial - Continued)

Bore Dia. B H9	Groove Dia. A h9	Groove Width G+.010	Minimum Piston Diameter P		Turcon® CST™ Seal Part No.
			5000 psi	6500 psi	
8.500	7.774	.750	8.467	8.481	PK0908500-T46NP
9.000	8.274	.750	8.967	8.981	PK0909000-T46NP
9.500	8.774	.750	9.467	9.481	PK0909500-T46NP
10.000	9.274	.750	9.967	9.981	PK0910000-T46NP
10.500	9.774	.750	10.467	10.481	PK0910500-T46NP
11.000	10.274	.750	10.967	10.981	PK0911000-T46NP
11.500	10.774	.750	11.467	11.481	PK0911500-T46NP
12.000	11.274	.750	11.967	11.981	PK0912000-T46NP
12.500	11.774	.750	12.468	12.482	PK0912500-T46NP
12.750	12.024	.750	12.718	12.732	PK0912750-T46NP
13.000	12.274	.750	12.968	12.982	PK0913000-T46NP
14.000	13.274	.750	13.968	13.982	PK0914000-T46NP
14.250	13.524	.750	14.218	14.232	PK0914250-T46NP
14.500	13.774	.750	14.468	14.482	PK0914500-T46NP
15.000	14.274	.750	14.968	14.982	PK0915000-T46NP
16.000	15.274	.750	15.968	15.982	PK0916000-T46NP
18.000	17.274	.750	17.968	17.982	PK0918000-T46NP
18.500	17.774	.750	18.468	18.482	PK0918500-T46NP



■ General

U-Cups are used primarily as seals for piston rods in hydraulics cylinders. U-Cups of polyurethane are proven elements, due to their good mechanical properties, for standard cylinder constructions, particularly for mobile hydraulics, under rough operating conditions.

Description

U-Cups are single-acting seal elements which have been successfully in use for many years in various forms and materials. They are proven as reliable and operationally safe seal elements and have proven to be very successful in conjunction with Turcon® Stepseal® K seals in heavy duty applications.

Choice of Profile

U-cups are available as single-lip and double-lip compact seals with various profile geometries. The choice of profile depends on the requirements of the particular application and the available groove.

All U-Cup forms are manufactured using the latest state-of-the-art technology with an oblique angled seal edge with asymmetric contact surface angles.

Method of Operation

The sealing effect of the U-Cup comes from the intrinsic preload of the seal body and from the compression of the seal lips during installation. In operating condition, the radial mechanical contact forces are complimented by the super-imposed system pressure which energizes the U-Cup.

At low stroke speeds, a U-Cup can tend to a stick-slip effect due to an inadequate film formation in the seal gap and to its material properties.

Material

The thermoplastic polyurethane (WUAQ3) material used for U-Cups has a high abrasion resistance, low compression set and exhibits a high resistance to gap extrusion. It is particularly resistant to tearing resulting from bending and tensile stresses and thus is very easy to install.

Advantages

Each U-Cup seal geometry (single or double lip) has associated advantages.

Single Lip Design Advantages:

- Good pressure-adapted sealing effect
- Unaffected by high loads and deflections of the piston rod
- Good resistance to gap extrusion
- Simple installation
- Lower friction in the low pressure range compared with double lipped versions

Double Lip Design Advantages:

- Good sealing effect
- Good abrasion resistance, wear resistant
- Good lubricant film formation in the seal gap
- Unaffected by sudden loads
- Simple installation

Technical Data

Pressure:	up to 40 MPa (5800 psi)
Speed:	up to 0,5 m/s (1.6 ft/s) reciprocating
Temperature:	-30°C to +100°C (-22°F to +212°F)
Media:	mineral oil-based hydraulic fluids, barely flammable hydraulic fluids. Less suitable for use with environmentally safe hydraulic fluids (bio-oils)



U-Cup (RUO) Dimensional Data

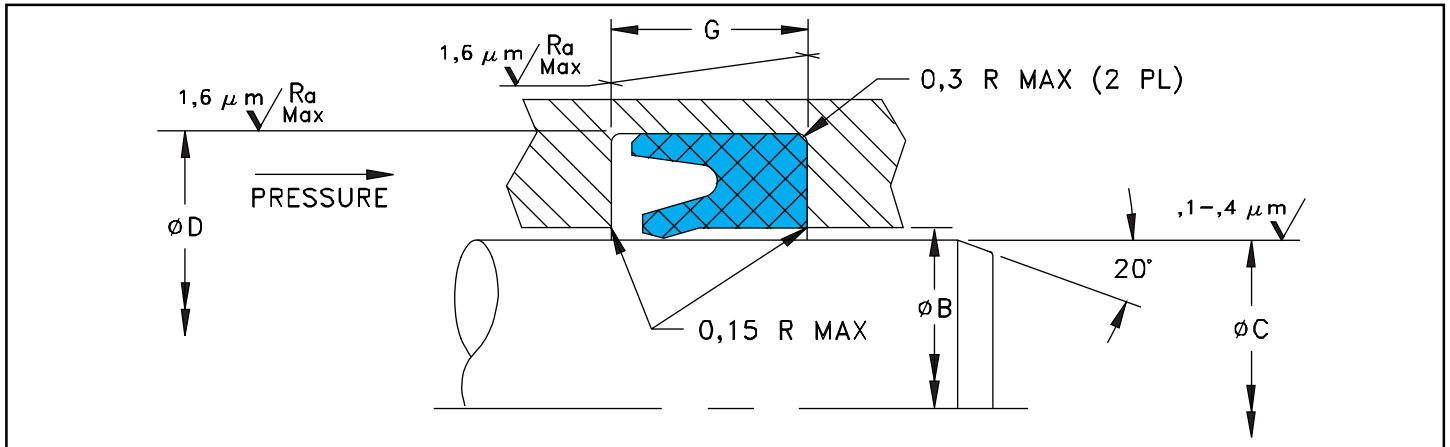

Table 8 U-Cup (RUO) Ordering Information (Metric)

Rod Dia. C f8	Groove Dia. D H9	Groove Width G+0.2	Maximum Rod Bore Diameter B			RUO U-Cup Polyurethane Part No.
			0-10 MPa	10-20 MPa	20-32 MPa	
10,0	20,0	9,0	10,76	10,56	10,26	RU0000100-WUAQ3
12,0	22,0	9,0	12,76	12,56	12,26	RU0000120-WUAQ3
16,0	22,0	6,0	16,76	16,56	16,26	RU0000160-WUAQ3
18,0	24,0	6,0	18,76	18,56	18,26	RU0000180-WUAQ3
20,0	26,0	6,0	20,75	20,55	20,25	RU0000200-WUAQ3
22,0	30,0	9,0	22,75	22,55	22,25	RU0000220-WUAQ3
25,0	32,0	7,0	25,75	25,55	25,25	RU0000250-WUAQ3
30,0	40,0	11,0	30,75	30,55	30,25	RU0000300-WUAQ3
32,0	45,0	11,0	32,74	32,54	32,24	RU0100320-WUAQ3
35,0	45,0	11,0	35,74	35,54	35,24	RU0000350-WUAQ3
36,0	46,0	11,0	36,74	36,54	36,24	RU0000360-WUAQ3
40,0	50,0	11,0	40,74	40,54	40,24	RU0000400-WUAQ3
52,0	62,0	11,0	52,72	52,52	52,22	RU0000520-WUAQ3
63,0	75,0	13,0	63,52	63,32	63,12	RU0000630-WUAQ3
70,0	80,0	13,0	70,52	70,32	70,12	RU0000700-WUAQ3
110,0	125,0	16,0	110,51	110,31	110,11	RU0001100-WUAQ3
120,0	135,0	16,0	120,51	120,31	120,11	RU0001200-WUAQ3



U-Cup (RU3) Dimensional Data

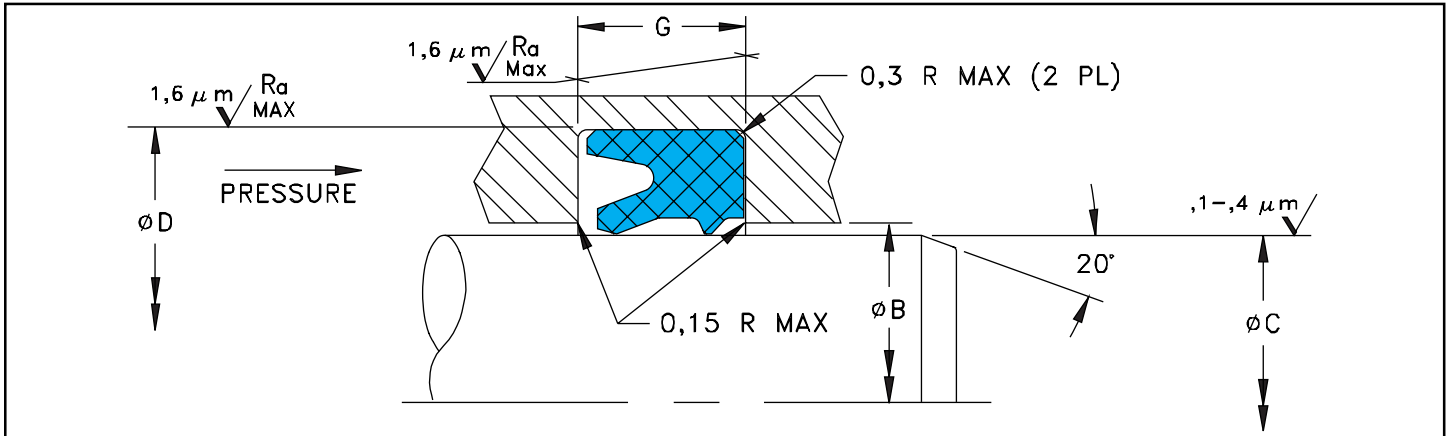

Table 9 U-Cup (RU3) Ordering Information (Metric)

Rod Dia. C f8	Groove Dia. D H9	Groove Width G+0,2	Maximum Rod Bore Diameter B			RU3 U-Cup Polyurethane Part No.
			0-10 MPa	10-20 MPa	20-32 MPa	
16,0	26,0	8,0	16,76	16,56	16,26	RU3000160-WUAQ3
18,0	28,0	8,0	18,76	18,56	18,26	RU3000180-WUAQ3
20,0	30,0	8,0	20,75	20,55	20,25	RU3000200-WUAQ3
22,0	32,0	8,0	22,75	22,55	22,25	RU3000220-WUAQ3
25,0	35,0	8,0	25,75	25,55	25,25	RU3000250-WUAQ3
28,0	38,0	8,0	28,75	28,55	28,25	RU3100280-WUAQ3
30,0	40,0	8,0	30,75	30,55	30,25	RU3000300-WUAQ3
32,0	42,0	8,0	32,74	32,54	32,24	RU3000320-WUAQ3
35,0	45,0	8,0	35,74	35,54	35,24	RU3000350-WUAQ3
36,0	46,0	8,0	36,74	36,54	36,24	RU3000360-WUAQ3
40,0	50,0	8,0	40,74	40,54	40,24	RU3100400-WUAQ3
45,0	55,0	8,0	45,74	45,54	45,24	RU3000450-WUAQ3
50,0	60,0	8,0	50,74	50,54	50,24	RU3000500-WUAQ3
55,0	65,0	8,0	55,74	55,54	55,24	RU3000550-WUAQ3
56,0	71,0	12,5	56,72	56,52	56,22	RU3100560-WUAQ3
60,0	70,0	12,5	60,52	60,32	60,12	RU3000600-WUAQ3
63,0	78,0	12,5	63,52	63,32	63,12	RU3000630-WUAQ3
65,0	75,0	12,5	65,52	65,32	65,12	RU3000650-WUAQ3
70,0	85,0	12,5	70,52	70,32	70,12	RU3000700-WUAQ3
75,0	85,0	12,5	75,52	75,32	75,12	RU3000750-WUAQ3
78,0	86,0	12,5	78,52	78,32	78,12	RU3000780-WUAQ3
80,0	95,0	12,5	80,52	80,32	80,12	RU3000800-WUAQ3
85,0	100,0	12,5	85,51	85,31	85,11	RU3000850-WUAQ3
90,0	105,0	12,5	90,51	90,31	90,11	RU3000900-WUAQ3
100,0	120,0	16,0	100,51	100,31	100,11	RU3101000-WUAQ3
105,0	120,0	10,0	105,51	105,31	105,11	RU3001050-WUAQ3
110,0	130,0	16,0	110,51	110,31	110,11	RU3001100-WUAQ3
125,0	145,0	16,0	125,49	125,29	125,09	RU3001250-WUAQ3
130,0	150,0	13,5	130,49	130,29	130,09	RU3001300-WUAQ3

Bold print indicates sizes conforming to ISO 5597



■ General

Traditionally, polyurethane U-Cups are used as rod seals in hydraulic cylinders. Polyurethane U-Cups are proven technology due to their success in standard hydraulic cylinders, often operating under extreme environmental conditions. The Zurcon® Z94 B+S U-Cup offers superior performance due to its unique material properties and finite element developed double lip geometry.

Description

The primary and secondary lips work in conjunction to provide a balanced point loading with maximum flexibility. The primary lip maximizes sealability with a shortened inner lip. Both inner and outer sealing edges are trimmed, rather than net molded, to provide better leakage control.

The secondary seal lip keeps surface contact to a minimum and helps prevent seal rotation during installation. The oil reservoir between the primary and secondary lips creates a lubrication pocket which reduces friction and stick-slip effects.

Advantages

Zurcon® Z94 advantages include high abrasion resistance, low compression set, and excellent tear resistance—all very important properties for a lip-type seal.

The Zurcon® Z94 polyurethane material exhibits high stiffness without a corresponding increase in hardness. The stiffness imparts excellent extrusion resistance at high pressure. The low hardness ensures resilience and flexibility of the seal, resulting in improved leakage control. The Busak+Shamban logo and size is permanently engraved in the seal for identification.

Material

Zurcon® Z94 is a unique turquoise colored polyurethane material, specially developed and trademarked by Busak+Shamban only for seals. It offers the right balance of chemical, mechanical and thermal properties required for optimum sealing performance.

Fields of Application

The Zurcon® B+S U-Cup is an excellent choice for many types of applications, particularly in mobile, forestry and mining equipment.

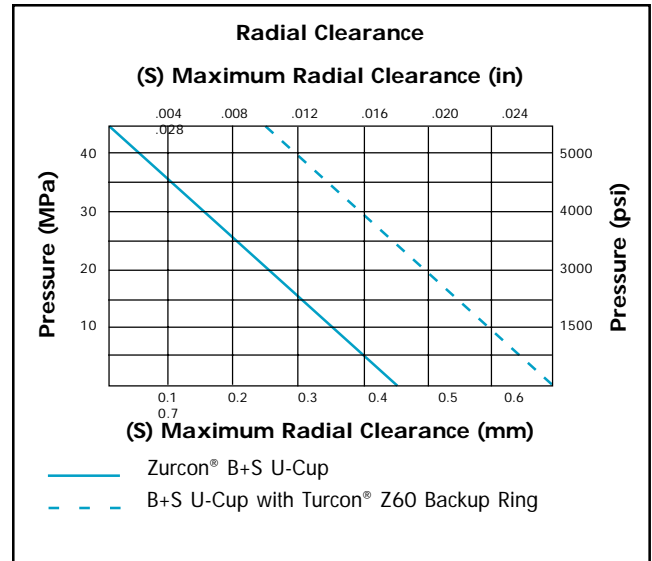

Figure 4 Relationship between radial clearance and operating pressure

Technical Data

Pressure: up to 45 MPa (6500 psi) with back-up ring. For pressure above 20 MPa (2900 psi), a back-up ring is recommended so that a larger clearance gap, as shown in Figure 4, can be achieved for smooth operation.

Speed: up to 0,8 m/s reciprocating (2.6 ft/s)

Temperature: -40°C to 100°C (-40°F to 212°F)

Media: Mineral oil, mineral based hydraulic fluids, gear oils.

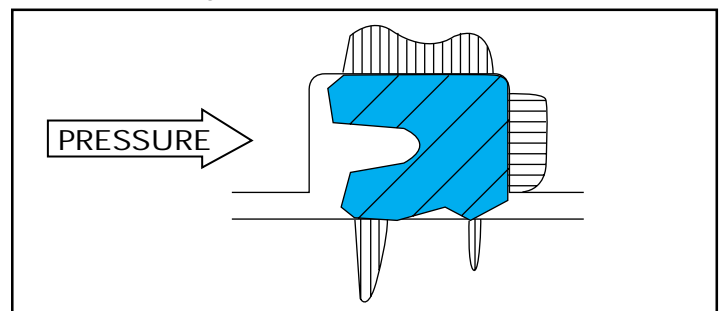

Figure 5 B+S U-Cup load profile.



Zurcon® B+S U-Cup Dimensional Data

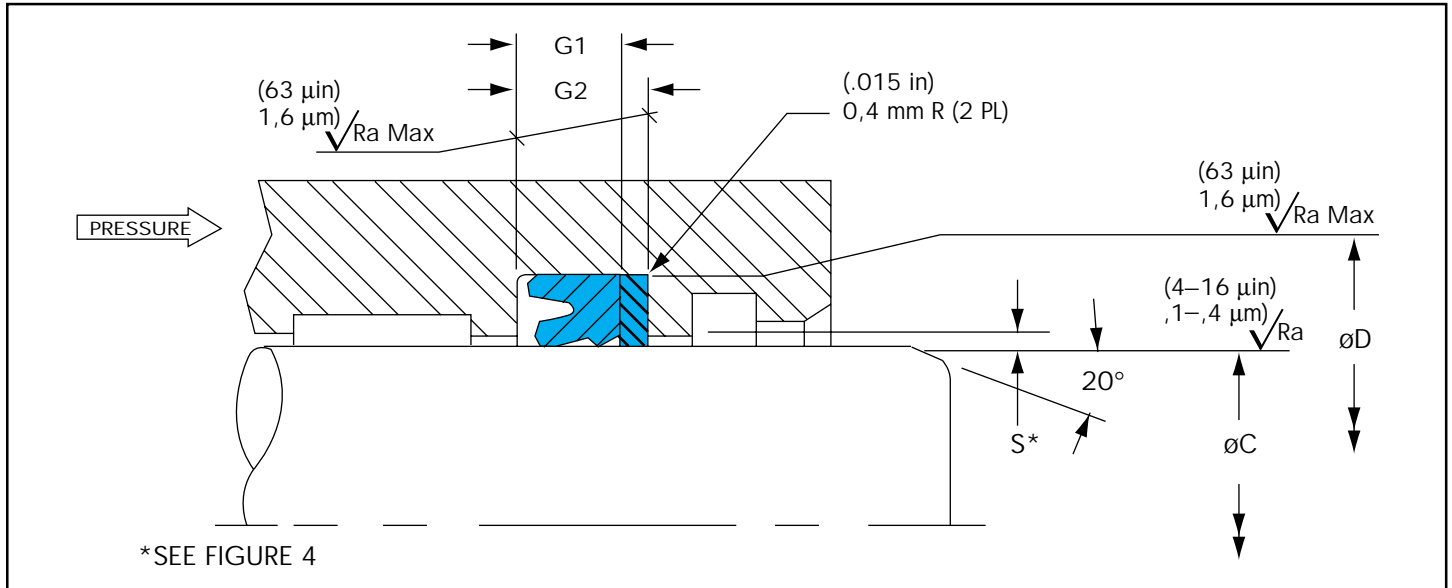

Table 10 Zurcon® B+S U-Cup Ordering Information (Metric)

Rod Diameter C f8	Groove Diameter D H9	Groove Width		B+S U-Cup Part Number	Back-up Ring ⁽¹⁾ Part Number
		U-Cup G1+0,2	With Backup G2+0,2		
*16,0	26,0	8,0	11,0	RUG400160-Z94	BGG400160-Z60
*18,0	28,0	8,0	11,0	RUG400180-Z94	BGG400180-Z60
*20,0	30,0	8,0	11,0	RUG400200-Z94	BGG400200-Z60
*22,0	32,0	8,0	11,0	RUG400220-Z94	BGG400220-Z60
28,0	38,0	8,0	11,0	RUG400280-Z94	BGG400280-Z60
30,0	40,0	8,0	11,0	RUG400300-Z94	BGG400300-Z60
32,0	42,0	8,0	11,0	RUG400320-Z94	BGG400320-Z60
35,0	45,0	8,0	11,0	RUG400350-Z94	BGG400350-Z60
36,0	46,0	8,0	11,0	RUG400360-Z94	BGG400360-Z60
40,0	50,0	8,0	11,0	RUG400400-Z94	BGG400400-Z60
45,0	55,0	8,0	11,0	RUG400450-Z94	BGG400450-Z60
50,0	60,0	8,0	11,0	RUG400500-Z94	BGG400500-Z60
50,0	65,0	12,5	15,5	RUG600500-Z94	BGG600500-Z60
56,0	71,0	12,5	15,5	RUG600560-Z94	BGG600560-Z60
60,0	75,0	12,5	15,5	RUG600600-Z94	BGG600600-Z60
63,0	78,0	12,5	15,5	RUG600630-Z94	BGG600630-Z60
65,0	80,0	12,5	15,5	RUG600650-Z94	BGG600650-Z60
70,0	85,0	12,5	15,5	RUG600700-Z94	BGG600700-Z60
75,0	90,0	12,5	15,5	RUG600750-Z94	BGG600750-Z60
80,0	95,0	12,5	15,5	RUG600800-Z94	BGG600800-Z60



Table 10 Zurcon® B+S U-Cup Ordering Information (Metric- Continued)

Rod Diameter C f8	Groove Diameter D H9	Groove Width		B+S U-Cup Part Number	Back-up Ring ⁽¹⁾ Part Number
		U-Cup	With Backup		
		G1+0,2	G2+0,2		
85,0	100,0	12,5	15,5	RUG600850-Z94	BGG600850-Z60
90,0	105,0	12,5	15,5	RUG600900-Z94	BGG600900-Z60
100,0	120,0	16,0	20,0	RUG701000-Z94	BGG701000-Z60
105,0	125,0	16,0	20,0	RUG701050-Z94	BGG701050-Z60
110,0	130,0	16,0	20,0	RUG701100-Z94	BGG701100-Z60
115,0	135,0	16,0	20,0	RUG701150-Z94	BGG701150-Z60
120,0	140,0	16,0	20,0	RUG701200-Z94	BGG701200-Z60

Note:

- (1) Back-up Rings are optional and must be ordered separately.
 (2) **Bold** print indicates sizes conforming to ISO 5597.
 (3) *Split gland required for installation of sizes less than 25mm.



Table 11 Zurcon® B+S U-Cup Ordering Information (Asian Metric)

Rod Diameter C f8	Groove Diameter D H9	Groove Width		B+S U-Cup Part Number	Back-up Ring ⁽¹⁾ Part Number
		U-Cup	With Backup		
		G1+0,2	G2+0,2		
*15,0	25,0	7,0	9,0	RUJ000150-Z94	BGJ000150-Z60
*20,0	30,0	7,0	9,0	RUJ000200-Z94	BGJ000200-Z60
*25,0	35,0	7,0	9,0	RUJ000250-Z94	BGJ000250-Z60
30,0	45,0	10,0	13,0	RUJ300300-Z94	BGJ300300-Z60
35,0	50,0	10,0	13,0	RUJ300350-Z94	BGJ300350-Z60
40,0	55,0	10,0	13,0	RUJ300400-Z94	BGJ300400-Z60
45,0	60,0	10,0	13,0	RUJ300450-Z94	BGJ300450-Z60
50,0	65,0	10,0	13,0	RUJ300500-Z94	BGJ300500-Z60
55,0	70,0	10,0	13,0	RUJ300550-Z94	BGJ300550-Z60
60,0	75,0	10,0	13,0	RUJ300600-Z94	BGJ300600-Z60
65,0	80,0	10,0	13,0	RUJ300650-Z94	BGJ300650-Z60
70,0	85,0	10,0	13,0	RUJ300700-Z94	BGJ300700-Z60
75,0	90,0	10,0	13,0	RUJ300750-Z94	BGJ300750-Z60
80,0	95,0	10,0	13,0	RUJ300800-Z94	BGJ300800-Z60
85,0	100,0	10,0	13,0	RUJ300850-Z94	BGJ300850-Z60
90,0	105,0	10,0	13,0	RUJ300900-Z94	BGJ300900-Z60
95,0	110,0	10,0	13,0	RUJ300950-Z94	BGJ300950-Z60
100,0	115,0	10,0	13,0	RUJ301000-Z94	BGJ301000-Z60
105,0	120,0	10,0	13,0	RUJ301050-Z94	BGJ301050-Z60
110,0	125,0	10,0	13,0	RUJ301100-Z94	BGJ301100-Z60
75,0	95,0	13,0	16,0	RUJ500750-Z94	BGJ500750-Z60
80,0	100,0	13,0	16,0	RUJ500800-Z94	BGJ500800-Z60
85,0	105,0	13,0	16,0	RUJ500850-Z94	BGJ500850-Z60
90,0	110,0	13,0	16,0	RUJ500900-Z94	BGJ500900-Z60
95,0	115,0	13,0	16,0	RUJ500950-Z94	BGJ500950-Z60
100,0	120,0	13,0	16,0	RUJ501000-Z94	BGJ501000-Z60
105,0	125,0	13,0	16,0	RUJ501050-Z94	BGJ501050-Z60
110,0	130,0	13,0	16,0	RUJ501100-Z94	BGJ501100-Z60
120,0	140,0	13,0	16,0	RUJ501200-Z94	BGJ501200-Z60
130,0	150,0	13,0	16,0	RUJ501300-Z94	BGJ501300-Z60
140,0	160,0	13,0	16,0	RUJ501400-Z94	BGJ501400-Z60
160,0	185,0	17,0	21,0	RUJ701600-Z94	BGJ701600-Z60
180,0	205,0	17,0	21,0	RUJ701800-Z94	BGJ701800-Z60
200,0	225,0	17,0	21,0	RUJ702000-Z94	BGJ702000-Z60

Note:

- (1) Back-up Rings are optional and must be ordered separately.
(2) *Split gland required for installation of sizes less than 25 mm.



Table 12 Zurcon® B+S U-Cup Ordering Information (Imperial)

Rod Diameter C f8	Groove Diameter D H9	Groove Width		B+S U-Cup Part Number	Back-up Ring ⁽¹⁾ Part Number
		U-Cup	With Backup		
		G1+.010	G2+.010		
*0.500	0.750	.250	.350	RUE100500-Z94	BGE100500-Z60
*0.625	0.875	.250	.350	RUE100625-Z94	BGE100625-Z60
*0.750	1.000	.250	.350	RUE100750-Z94	BGE100750-Z60
*0.875	1.125	.250	.350	RUE100875-Z94	BGE100875-Z60
*1.000	1.250	.250	.350	RUE101000-Z94	BGE101000-Z60
1.125	1.500	.343	.468	RUE201125-Z94	BGE201125-Z60
1.250	1.625	.343	.468	RUE201250-Z94	BGE201250-Z60
1.375	1.750	.343	.468	RUE201375-Z94	BGE201375-Z60
1.500	2.000	.406	.531	RUE301500-Z94	BGE301500-Z60
1.625	2.125	.406	.531	RUE301625-Z94	BGE301625-Z60
1.750	2.250	.406	.531	RUE301750-Z94	BGE301750-Z60
1.875	2.375	.406	.531	RUE301875-Z94	BGE301875-Z60
2.000	2.500	.406	.531	RUE302000-Z94	BGE302000-Z60
2.125	2.625	.406	.531	RUE302125-Z94	BGE302125-Z60
2.250	2.750	.406	.531	RUE302250-Z94	BGE302250-Z60
2.375	2.875	.406	.531	RUE302375-Z94	BGE302375-Z60
2.500	3.000	.406	.531	RUE302500-Z94	BGE302500-Z60
2.750	3.250	.406	.531	RUE302750-Z94	BGE302750-Z60
3.000	3.500	.406	.531	RUE303000-Z94	BGE303000-Z60
3.250	3.750	.406	.531	RUE303250-Z94	BGE303250-Z60
3.500	4.000	.406	.531	RUE303500-Z94	BGE303500-Z60
4.000	4.500	.406	.531	RUE304000-Z94	BGE304000-Z60
4.500	5.125	.531	.656	RUE404500-Z94	BGE404500-Z60
5.000	5.625	.531	.656	RUE405000-Z94	BGE405000-Z60
5.500	6.125	.531	.656	RUE405500-Z94	BGE405500-Z60
6.000	6.750	.656	.806	RUE506000-Z94	BGE506000-Z60
6.500	7.250	.656	.806	RUE506500-Z94	BGE506500-Z60
7.000	8.000	.781	.931	RUE607000-Z94	BGE607000-Z60
7.500	8.500	.781	.931	RUE607500-Z94	BGE607500-Z60
8.000	9.000	.781	.931	RUE608000-Z94	BGE608000-Z60

Note:

- (1) Back-up Rings are optional and must be ordered separately.
- (2) *Split gland required for installation of sizes less than 1.000 inches.



■ General

Turcon® Stepseal® K seals provide excellent results where robust seals are required, for example in earth-moving equipment, presses, servo valves and other situations where tool machine-type requirements have to be met. The Turcon® Stepseal® K is patented; number P3225906.

Turcon® Stepseal® K offers increased sealing characteristics due to its modified sealing edges.

The Turcon® Stepseal® K can achieve reliable operation of all high-pressure and low-pressure systems over extensive speed and frequency ranges.

Description

Turcon® Stepseal® K is a single-acting element. It must always be installed together with an O-Ring.

This means that the seal consists of two separate components: a Turcon® profile ring, (the primary seal), and an O-Ring (which acts as an energizer and secondary seal).

Advantages

- No pressure trapping and multiseal installation can be used
- Excellent buffer seal for high impact systems
- Excellent anti-friction characteristics
- No stick-slip effect during start-up
- No adhesion effect
- High degree of resistance to abrasion
- Long service life
- Good dynamic and static sealing characteristics
- Used with and without lubrication
- Simple groove configuration
- Single installation
- Available for any piston and rod diameter up to 2500mm (98 inches)

Fields of Application

Turcon® Stepseal® K is used as a sealing element for plungers and rods with reciprocating movements.

Operating Ranges

Pressure:	up to 80 MPa (11,600 psi) (for pressure above 32 MPa, consult Busak+Shamban)
Speed:	up to 15 m/s (50 ft/s)
Temperature:	-54°C to +200°C (-65°F to +392°F) (depends on O-Ring compound)
Media:	mineral oil-based hydraulic fluids, barely flammable hydraulic fluids, environmentally safe hydraulic fluids (bio-oils), water and others, depending on the material

Leakage

In the interest of long service life, Turcon® Stepseal® K is designed to offer defined hydrodynamic friction characteristics across a wide pressure and speed range in conjunction with optimum sealing properties. In many cases where Turcon® seals are used, a run-in time is necessary until the seal functions properly.

Friction

Turcon® seals present the following advantages:

- Increased resistance to extrusion
- Less friction
- No stick-slip effect (jerky slippage) even after a long period out of operation
- Dimensionally stable under the effects of temperature

Material Properties

Turcon® T46 is an extremely wear-resistant material with a high degree of inherent rigidity which retains its shape under extreme conditions. Turcon® is resistant to nearly all chemicals. Aging and exposure to light do not bring about changes. Moisture absorption is less than 0.01%.



Leakage

From a technical point of view, an absolutely leakproof seal can only be justified in a few individual cases.

The high stresses created by the operating pressure on the sealing surface lead to increased abrasion and thus to a reduced service life of the seal in the case of completely dry operation.

In the interest of long service life, Turcon® Stepseal® K is designed to offer defined hydrodynamic friction characteristics across a wide pressure and speed range in conjunction with optimum sealing properties.

The leakage characteristics of various rod seals are represented in Figure 6.

Test Data:

Rod Diameter	20 mm (.82 inches)
Stroke	40 mm (1.63 inches)
Average Speed	0,1 m/s (.33 ft/s)
Medium	Hydraulic oil Esstic 50
Temperature	+20°C (+68°F)

Friction

The friction force characteristics of Turcon® seals are fundamentally different to those of elastomer seals.

Figure 7 shows the dependence of friction forces upon the operating pressure.

Test Data:

Rod Diameter	50 mm (1.96 inches)
Average Speed	0,1 m/s (.33 ft/s)
Medium	Hydraulic oil HLP 46
Temperature	+20°C (+68°F)
Grooves	In accordance with details in catalog
Mating surfaces	Hard chromeplated polished
	Rt = 4,2 mm
	Ra = 0,4 mm
	Rz = 3,1 mm
Sealing compound No.	T46

Life

By virtue of the outstanding low friction properties and high resistance to abrasion of Turcon® materials, their service life is by far longer than that of conventional seals.

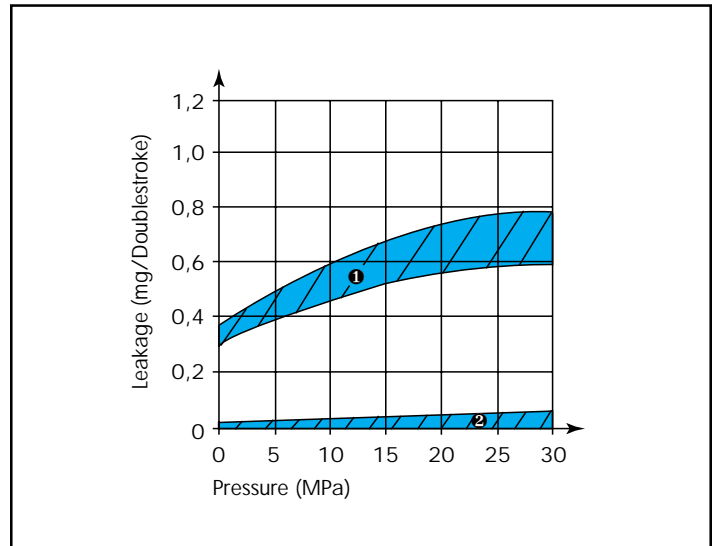

Figure 6 1) O-Ring with two Back-up rings
2) Turcon® Stepseal® K

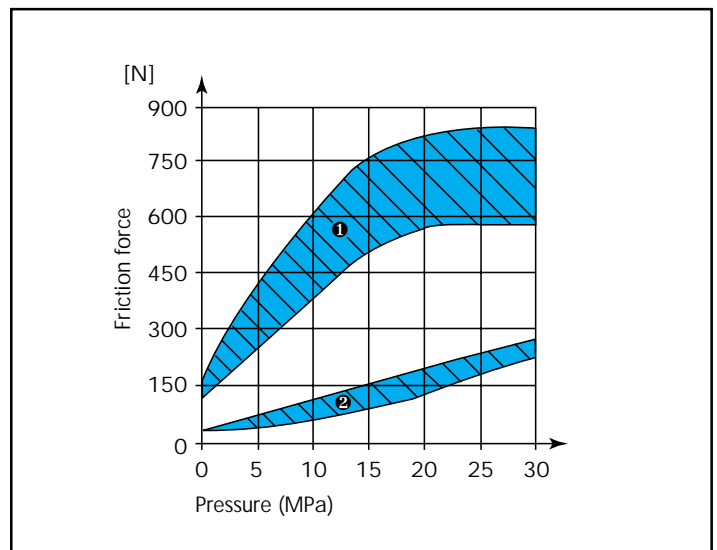

Figure 7 1) U-Cup
2) Turcon® Stepseal® K



Turcon® Stepseal® K Dimensional Data

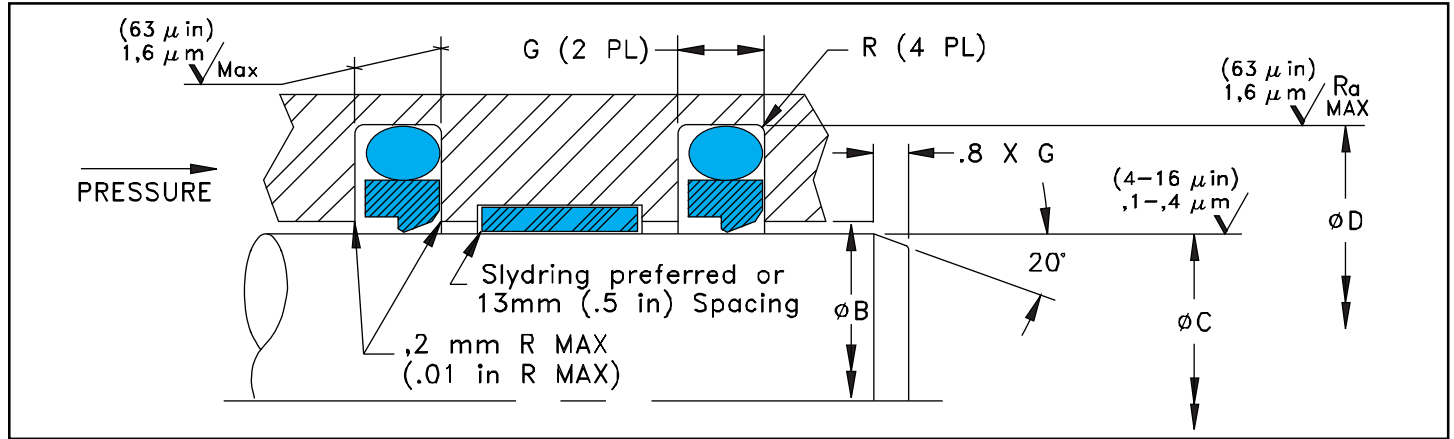

Table 13 Turcon® Stepseal® K Ordering Information (Metric)

Rod Dia. C f8	Groove Dia. D H9	Groove Width G+0,2	Maximum Rod Bore Diameter B			Radius R (Max)	O-Ring Dash No.	Turcon® Stepseal®K Turcon® T46
			0-10 MPa	10-20 MPa	20-32 MPa			Part No.
12	19,3	3,2	12,6	12,5	12,3	0,5	114	RS1300120-T46
14	21,3	3,2	14,6	14,5	14,3	0,5	115	RS1300140-T46
15	22,3	3,2	15,6	15,5	15,3	0,5	116	RS1300150-T46
16	23,3	3,2	16,6	16,5	16,3	0,5	116	RS1300160-T46
18	25,3	3,2	18,6	18,5	18,3	0,5	117	RS1300180-T46
20	30,7	4,2	20,7	20,5	20,4	0,7	214	RS1300200-T46
22	32,7	4,2	22,7	22,5	22,4	0,7	215	RS1300220-T46
25	35,7	4,2	25,7	25,5	25,4	0,7	217	RS1300250-T46
28	38,7	4,2	28,7	28,5	28,4	0,7	219	RS1300280-T46
30	40,7	4,2	30,7	30,5	30,4	0,7	220	RS1300300-T46
32	42,7	4,2	32,7	32,5	32,4	0,7	221	RS1300320-T46
35	45,7	4,2	35,7	35,5	35,4	0,7	223	RS1300350-T46
36	46,7	4,2	36,7	36,5	36,4	0,7	223	RS1300360-T46
38	53,1	6,3	38,8	38,6	38,4	1,2	327	RS1300380-T46
40	55,1	6,3	40,8	40,6	40,4	1,2	328	RS1300400-T46
42	57,1	6,3	42,8	42,6	42,4	1,2	328	RS1300420-T46
45	60,1	6,3	45,8	45,6	45,4	1,2	329	RS1300450-T46
50	65,1	6,3	50,8	50,6	50,4	1,2	331	RS1300500-T46
55	70,1	6,3	55,8	55,6	55,4	1,2	332	RS1300550-T46
56	71,1	6,3	56,8	56,6	56,4	1,2	333	RS1300560-T46
60	75,1	6,3	60,8	60,6	60,4	1,2	334	RS1300600-T46
63	78,1	6,3	63,8	63,6	63,4	1,2	335	RS1300630-T46
65	80,1	6,3	65,8	65,6	65,4	1,2	336	RS1300650-T46
70	85,1	6,3	70,8	70,6	70,4	1,2	337	RS1300700-T46
75	90,1	6,3	75,8	75,6	75,4	1,2	339	RS1300750-T46
80	95,1	6,3	80,8	80,6	80,4	1,2	340	RS1300800-T46
85	100,1	6,3	85,8	85,6	85,4	1,2	342	RS1300850-T46
90	105,1	6,3	90,8	90,6	90,4	1,2	343	RS1300900-T46
95	110,1	6,3	95,8	95,6	95,4	1,2	345	RS1300950-T46
100	115,1	6,3	100,8	100,6	100,4	1,2	347	RS1301000-T4 6

Bold print indicates sizes conforming to ISO 3320



Table 13 Turcon® Stepseal® K Ordering Information (Metric - Continued)

Rod Dia. C f8	Groove Dia. D H9	Groove Width G+0,2	Maximum Rod Bore Diameter B			Radius R (Max)	O-Ring Dash No.	Turcon® Stepseal®K Turcon® T46 Part No.
			0-10 MPa	10-20 MPa	20-32 MPa			
105	120,1	6,3	105,8	105,6	105,4	1,2	348	RS1301050-T46
110	125,1	6,3	110,8	110,6	110,4	1,2	350	RS1301100-T46
115	130,1	6,3	115,8	115,6	115,4	1,2	351	RS1301150-T46
120	135,1	6,3	120,8	120,6	120,4	1,2	353	RS1301200-T46
125	140,1	6,3	125,8	125,6	125,4	1,2	355	RS1301250-T46
130	145,1	6,3	130,8	130,6	130,4	1,2	356	RS1301300-T46
135	150,1	6,3	135,8	135,6	135,4	1,2	358	RS1301350-T46
140	155,1	6,3	140,8	140,6	140,4	1,2	359	RS1301400-T46
150	165,1	6,3	150,8	150,6	150,4	1,2	362	RS1301500-T46
160	175,1	6,3	160,8	160,6	160,4	1,2	363	RS1301600-T46
170	185,1	6,3	170,8	170,6	170,4	1,2	365	RS1301700-T46
180	195,1	6,3	180,8	180,6	180,4	1,2	366	RS1301800-T46
190	205,1	6,3	190,8	190,6	190,4	1,2	368	RS1301900-T46
200	220,5	8,1	201,1	200,8	200,5	1,5	445	RS1302000-T46
210	230,5	8,1	211,1	210,8	210,5	1,5	446	RS1302100-T46
220	240,5	8,1	221,1	220,8	220,5	1,5	447	RS1302200-T46
230	250,5	8,1	231,1	230,8	230,5	1,5	448	RS1302300-T46
240	260,5	8,1	241,1	240,8	240,5	1,5	449	RS1302400-T46
250	270,5	8,1	251,1	250,8	250,5	1,5	449	RS1302500-T46
260	284,0	8,1	261,1	260,8	260,5	1,5	450	RS1302600-T46
270	294,0	8,1	271,1	270,8	270,5	1,5	451	RS1302700-T46
280	304,0	8,1	281,1	280,8	280,5	1,5	452	RS1302800-T46
290	314,0	8,1	291,1	290,8	290,5	1,5	453	RS1302900-T46
300	324,0	8,1	301,1	300,8	300,5	1,5	454	RS1303000-T46
310	334,0	8,1	311,1	310,8	310,5	1,5	454	RS1303100-T46
320	344,0	8,1	321,1	320,8	320,5	1,5	455	RS1303200-T46
330	354,0	8,1	331,1	330,8	330,5	1,5	456	RS1303300-T46
340	364,0	8,1	341,1	340,3	340,5	1,5	457	RS1303400-T46
350	374,0	8,1	351,1	350,8	350,5	1,5	458	RS1303500-T46
360	384,0	8,1	361,1	360,8	360,5	1,5	458	RS1303600-T46
370	394,0	8,1	371,1	370,8	370,5	1,5	459	RS1303700-T46
380	404,0	8,1	381,1	380,8	380,5	1,5	460	RS1303800-T46
390	414,0	8,1	391,1	390,8	390,5	1,5	461	RS1303900-T46
400	424,0	8,1	401,1	400,8	400,5	1,5	461	RS1304000-T46
420	444,0	8,1	421,03	420,53	420,33	1,5	463	RS1304200-T46
440	464,0	8,1	441,03	440,53	440,33	1,5	464	RS1304400-T46
450	474,0	8,1	451,03	450,53	450,33	1,5	465	RS1304500-T46
460	484,0	8,1	461,03	460,53	460,33	1,5	466	RS1304600-T46
480	504,0	8,1	481,03	480,53	480,33	1,5	468	RS1304800-T46
500	524,0	8,1	501,02	500,52	500,32	1,5	469	RS1305000-T46
550	574,0	8,1	551,02	550,52	550,32	1,5	471	RS1305500-T46
600	624,0	8,1	601,02	600,52	600,32	1,5	473	RS1306000-T46
650	677,0	9,5	651,20	650,80	650,40	2,7	8,4x665	RS1306500-T46
700	727,3	9,5	701,20	700,80	700,40	2,7	8,4x715	RS1307000-T46
800	827,3	9,5	801,18	800,78	800,38	2,7	8,4x810	RS1308000-T46
900	927,3	9,5	901,18	900,78	900,38	2,7	8,4x888	RS1309000-T46
1000	1038,0	13,8	1001,77	1001,17	1000,97	3,2	12x1016	RS13X1000-T46

Bold print indicates sizes conforming to ISO 3320.

Other dimensions and all intermediate sizes up to 2500mm diameter can be supplied.



Table 14 Turcon® Stepseal® K Ordering Information (Imperial)

Rod Dia. C f8	Groove Dia. D H9	Groove Width G+.008	Maximum Rod Bore øB Pressure (psi)			Radius R (Max)	O-Ring Dash No.	Turcon® Stepseal®K Turcon® T46 Part No.
			0 to 1000	1000 to 3000	3000 to 4500			
.375	.662	.126	.399	.393	.389	.020	112	RSC100375-T46
.500	.787	.126	.524	.518	.514	.020	114	RSC100500-T46
.625	.912	.126	.649	.643	.639	.020	116	RSC100625-T46
.750	1.171	.165	.774	.768	.766	.025	213	RSC200750-T46
.875	1.296	.165	.899	.893	.891	.025	215	RSC200875-T46
1.000	1.421	.165	1.024	1.018	1.016	.025	217	RSC201000-T46
1.125	1.546	.165	1.149	1.143	1.141	.025	219	RSC201125-T46
1.250	1.671	.165	1.274	1.268	1.266	.025	221	RSC201250-T46
1.375	1.796	.165	1.399	1.393	1.391	.025	222	RSC201375-T46
1.500	2.094	.248	1.529	1.522	1.518	.030	327	RSC301500-T46
1.750	2.344	.248	1.778	1.771	1.767	.030	329	RSC301750-T46
1.875	2.469	.248	1.903	1.896	1.892	.030	330	RSC301875-T46
2.000	2.594	.248	2.028	2.021	2.017	.030	331	RSC302000-T46
2.250	2.844	.248	2.278	2.271	2.267	.030	333	RSC302250-T46
2.375	2.969	.248	2.403	2.396	2.392	.030	334	RSC302375-T46
2.500	3.094	.248	2.528	2.521	2.517	.030	335	RSC302500-T46
2.625	3.219	.248	2.653	2.646	2.642	.030	336	RSC302625-T46
2.750	3.344	.248	2.778	2.771	2.767	.030	337	RSC302750-T46
3.000	3.594	.248	3.028	3.021	3.017	.030	339	RSC303000-T46
3.250	3.844	.248	3.278	3.271	3.267	.030	341	RSC303250-T46
3.500	4.094	.248	3.528	3.521	3.517	.030	343	RSC303500-T46
3.750	4.344	.248	3.778	3.771	3.767	.030	345	RSC303750-T46
4.000	4.594	.248	4.028	4.021	4.017	.030	347	RSC304000-T46
4.250	4.844	.248	4.278	4.271	4.267	.030	349	RSC304250-T46
4.500	5.094	.248	4.527	4.520	4.516	.030	351	RSC304500-T46
4.750	5.344	.248	4.777	4.770	4.766	.030	353	RSC304750-T46
5.000	5.594	.248	5.027	5.020	5.016	.030	355	RSC305000-T46
5.500	6.094	.248	5.527	5.520	5.516	.030	359	RSC305500-T46
6.000	6.594	.248	6.027	6.020	6.016	.030	362	RSC306000-T46
6.500	7.094	.248	6.527	6.520	6.516	.030	364	RSC306500-T46
7.000	7.594	.248	7.027	7.020	7.016	.030	366	RSC307000-T46
7.500	8.094	.248	7.527	7.520	7.516	.030	368	RSC307500-T46
8.000	8.807	.319	8.026	8.019	8.017	.035	445	RSC408000-T46
8.500	9.307	.319	8.526	8.519	8.517	.035	446	RSC408500-T46
9.000	9.807	.319	9.026	9.019	9.017	.035	447	RSC409000-T46

Bold print indicates BusakShamban Preferred Design sizes.



Table 14 Turcon® Stepseal® K Ordering Information (Imperial - Continued)

Rod Dia. C f8	Groove Dia. D H9	Groove Width G+.008	Maximum Rod Bore ϕ B Pressure (psi)			Radius R (Max)	O-Ring Dash No.	Turcon® Stepseal®K Turcon® T46 Part No.
			0 to 1000	1000 to 3000	3000 to 4500			
9.500	10.307	.319	9.526	9.519	9.517	.035	448	RSC409500-T46
10.000	10.945	.319	10.026	10.019	10.017	.035	450	RSC510000-T46
10.500	11.445	.319	10.526	10.519	10.517	.035	451	RSC510500-T46
11.000	11.945	.319	11.026	11.019	11.017	.035	452	RSC511000-T46
11.500	12.445	.319	11.526	11.519	11.517	.035	453	RSC511500-T46
12.000	12.945	.319	12.026	12.019	12.017	.035	454	RSC512000-T46
12.500	13.445	.319	12.526	12.519	12.517	.035	454	RSC512500-T46
13.000	13.945	.319	13.025	13.018	13.016	.035	455	RSC513000-T46
13.500	14.445	.319	13.525	13.518	13.516	.035	456	RSC513500-T46
14.000	14.945	.319	14.025	14.018	14.016	.035	457	RSC514000-T46
14.500	15.445	.319	14.525	14.518	14.516	.035	458	RSC514500-T46
15.000	15.945	.319	15.025	15.018	15.016	.035	459	RSC515000-T46

Bold print indicates BusakShamban Preferred Design sizes.

Ordering Example

Tolerances used are per ISO-286 ISO system of limits and fits. The tolerances are converted from metric and rounded to the nearest three place decimal.

The rod bore in the above table is for when the seal is specified with Slydrings®. When not incorporating Slydrings®, the diametral clearance should be reduced.

Consult your Busak+Shamban sales office for diameters that exceed those listed in the above table.

Order O-Ring separately.

The matching O-Ring may have larger or smaller OD than the groove diameter. However, the difference shall not affect the performance and reliability of the seal once the Stepseal® K is installed properly.

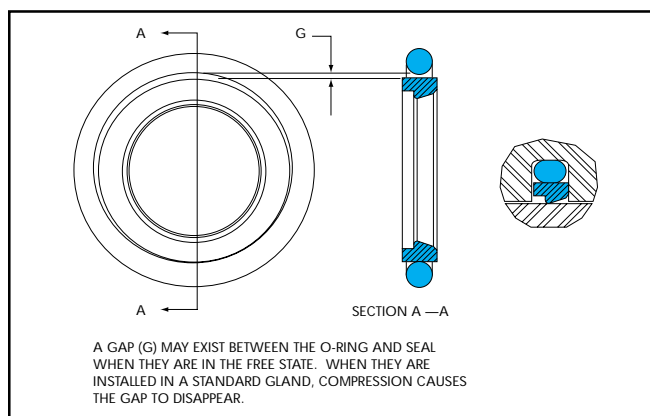
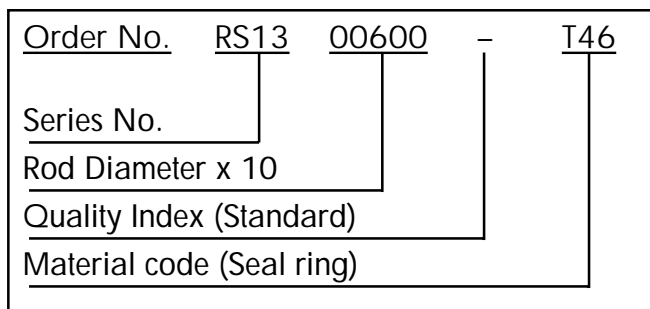



■ General

The Turcon® Glyd Ring® HPR was designed and patented for ultra high pressure, zero leakage, and long, consistent service life. It is a unidirectional rod seal used in reciprocating or helical hydraulic applications. The Turcon® Glyd Ring® HPR works as a primary seal with pressure relieving capability to prevent pressure traps between sealing elements.

The seal design offers exceptional performance in heavy contamination environments, maintaining rod contact during extreme rod deflection.

Description

The Turcon® Glyd Ring® HPR sealing components are integrated in a synergistic way to provide a compact seal design and high performance characteristics in a single groove configuration. The Turcon® Glyd Ring® HPR consists of a uniquely configured pressure relieving Turel® elastomer that radially loads the dual material Turcon® and HiMod® Glyd Ring®.

Under rod extension, the Turcon® Glyd Ring® HPR provides a specified lubrication film to the downstream bearing and secondary seal. The unique geometry of the Turcon® Glyd Ring® HPR allows it to back-pump fluid upon rod retraction, thereby controlling the lubrication level.

Advantages

- Closed groove design
- Compact seal assembly
- Patented seal geometry
- Easy installation
- No adhesion effect
- High pressure extrusion resistance
- Large rod clearance accommodation
- Wear resistant
- Low friction
- Contamination resistant
- Long stroke reliability
- Cost effective
- Fluid compatibility
- Wide temperature range
- Size flexibility
- Pressure venting
- Consistent performance

Technical Data

Operating Pressure: 50 MPa max (7500 psi)
 Temperature Limits: -54°C to +120°C (-65°F to +248°F)
 Velocity: 1,5 m/s (5.0 ft/s)

Material

Turcon® (Material Code: T29)

Mating surfaces: Stainless steel, chrome plated steel, mild steel, ductile iron
 Temperature range: -54°C to +200°C (-65°F to +392°F)
 Applications: Standard hydraulic service, short and long stroke applications, low lubrication service, improved wear resistance

HiMod® (Material Code: MiMod 60; ordering code:P)

Temperature range: -54°C to +120°C (-65°F to +248°F)
 Fluid compatibility: Hydraulic oil

Turel® (Material Code: NP)

Hardness shore A: 70
 Temperature range: -54°C to +135°C (-65°F to +275°F)
 Fluid compatibility: Hydraulic oil, diester based lubricants, ethylene glycol based fluids

Fields of Application

The Turcon® Glyd Ring® HPR is used in applications for the following markets: construction, hydraulic press, oilfield/CPI, and excavators.

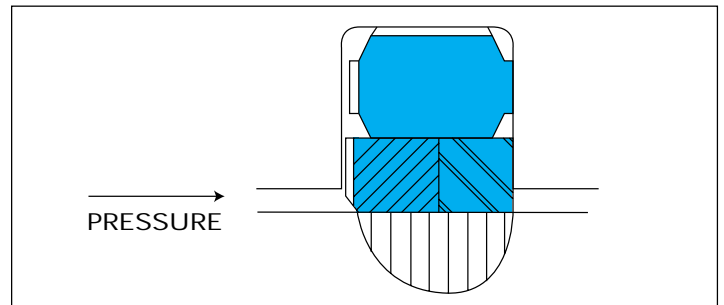

Figure 8 Turcon® Glyd Ring® HPR load profile



Glyd Ring® HPR Dimensional Data

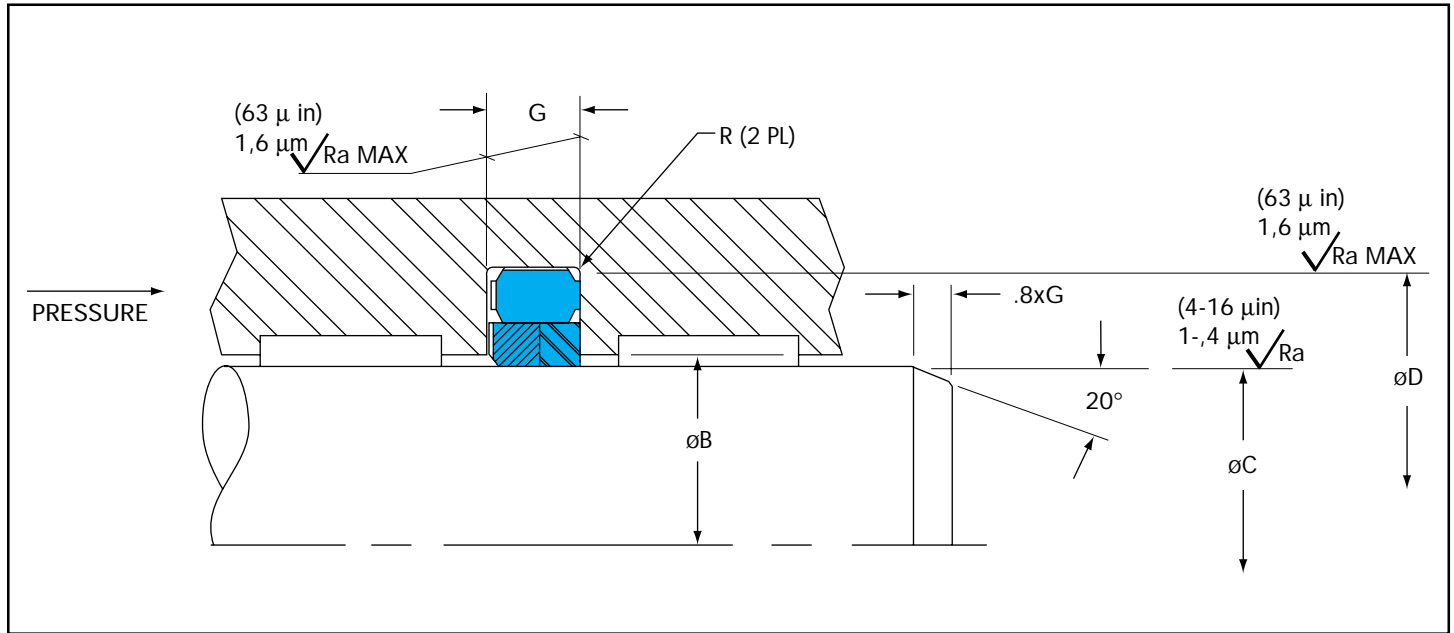

Table 15 Glyd Ring® HPR Ordering Information (Metric)

Rod Diameter C f8	Groove Diameter D H9	Maximum Rod Bore Diameter B		Width G+0,2	Radius R (Max)	Standard Turcon® Glyd Ring® HPR Part Number
		34,5 MPa	45,0 MPa			
50	65,50	50,53	50,43	6,3	0,9	RGP700500-T29NP
55	70,50	55,52	55,42	6,3	0,9	RGP700550-T29NP
60	75,50	60,52	60,42	6,3	0,9	RGP700600-T29NP
65	80,50	65,52	65,42	6,3	0,9	RGP700650-T29NP
70	85,50	70,52	70,42	6,3	0,9	RGP700700-T29NP
75	90,50	75,52	75,42	6,3	0,9	RGP700750-T29NP
80	95,50	80,51	80,41	6,3	0,9	RGP700800-T29NP
85	100,50	85,51	85,41	6,3	0,9	RGP700850-T29NP
90	105,50	90,51	90,41	6,3	0,9	RGP700900-T29NP
95	110,50	95,51	95,41	6,3	0,9	RGP700950-T29NP
100	115,50	100,51	100,41	6,3	0,9	RGP701000-T29NP
105	120,50	105,51	105,41	6,3	0,9	RGP701050-T29NP
110	125,50	110,51	110,41	6,3	0,9	RGP701100-T29NP
120	135,50	120,49	120,39	6,3	0,9	RGP701200-T29NP
130	145,50	130,49	130,39	6,3	0,9	RGP701300-T29NP
140	155,50	140,49	140,39	6,3	0,9	RGP701400-T29NP



Table 16 Turcon® Glyd Ring® HPR Ordering Information (Imperial)

Rod Diameter C f8	Groove Diameter D H9	Maximum Rod Bore Diameter B		Width G+.008	Radius R (Max)	Standard Turcon® Glyd Ring® HPR Part Number
		5000 psi	6500 psi			
1.750	2.360	1.771	1.767	.248	.035	RGP301750-T29NP
2.000	2.610	2.021	2.017	.248	.035	RGP302000-T29NP
2.250	2.860	2.271	2.267	.248	.035	RGP302250-T29NP
2.500	3.110	2.521	2.517	.248	.035	RGP302500-T29NP
2.750	3.360	2.771	2.767	.248	.035	RGP302750-T29NP
3.000	3.610	3.021	3.017	.248	.035	RGP303000-T29NP
3.250	3.860	3.270	3.266	.248	.035	RGP303250-T29NP
3.500	4.110	3.520	3.516	.248	.035	RGP303500-T29NP
4.000	4.610	4.020	4.016	.248	.035	RGP304000-T29NP
4.500	5.110	4.520	4.516	.248	.035	RGP304500-T29NP
5.000	5.610	5.020	5.016	.248	.035	RGP305000-T29NP

Ordering Example

The rod bore in the above table is for when the seal is specified with Slydrings®. When not incorporating Sydrings®, the diametral clearance should be reduced.

Consult your Busak+Shamban sales office for diameters that exceed those listed in the above table.

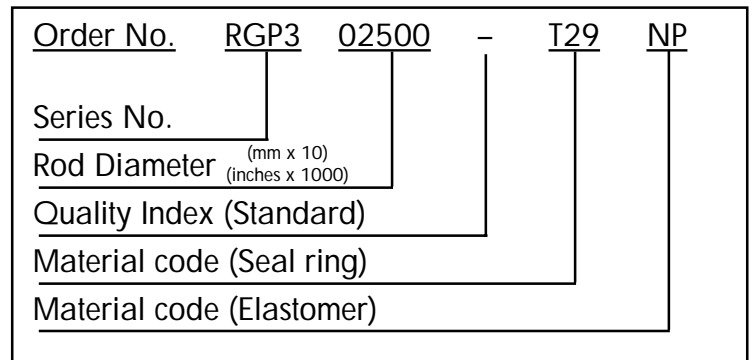



■ General

Wiper rings are placed on rods, plungers, etc., that move axially in hydraulic cylinders. During movement, dust particles can find their way into the hydraulic system and cause damage or premature wear of the seals, guides and bearings. This can be prevented by using the DA 17 Wiper.

Description

The DA 17 wiper is a double working nitrile wiper. It is a synthetic rubber element with two flexible lips of different geometry. The wiper lips are designed to wipe off dust and provide light sealing. It takes advantage of radial tension to wipe off particles, dust, and water.

The inner lips are designed to perform a sealing function when pressurized. Static sealing is accomplished by pressure from the outer groove.

The application works extremely well in conjunction with our rod seals, such as the Turcon® Stepseal® K or B+S U-Cup.

Advantages

- Good scraping action, even with highly adhering dirt
- Compact design
- Easily fitted and dismantled (no special tools required)
- Economical price
- Simple groove design
- Slight rotary and oscillating movements do not affect performance

Material

The standard material is a hard wearing nitrile rubber with a hardness of approximately 90 Shore A.

Technical Data

Speed:	Reciprocating up to 1 m/s (3 ft/s)
Temperature:	-30°C to +110°C (-22°F to +230°F)
Media:	Oil, air and oil-in-water emulsions

Fields of Application

The double wiper DA 17 is preferably used for rods and plungers in reciprocating applications.

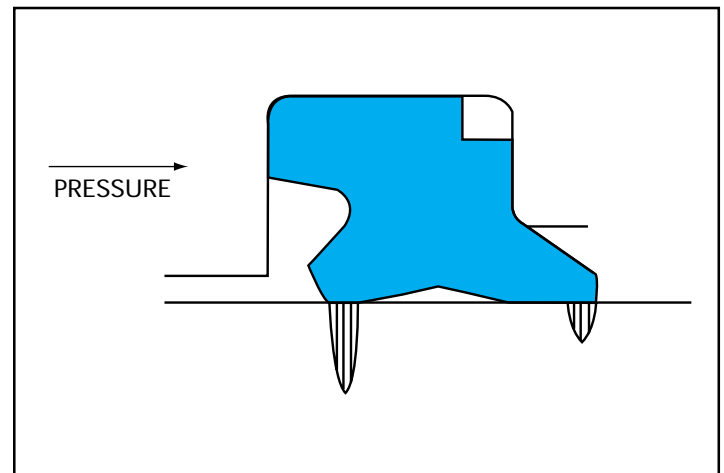

Figure 9 DA 17 Load Profile



DA 17 Dimensional Data

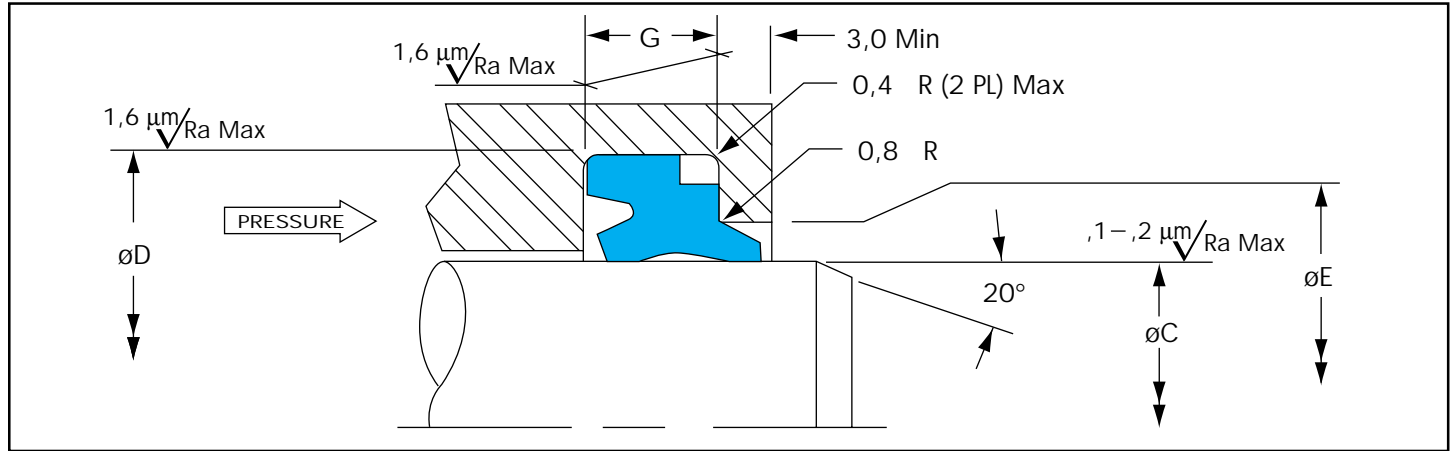

Table 17 DA 17 Ordering Information (Metric only)

Rod Dia.	Groove Dia.	Groove Width	Exit Dia.	DA 17 Wiper Molded Nitrile	Rod Dia.	Groove Dia.	Groove Width	Exit Dia.	DA 17 Wiper Molded Nitrile
C f8	D H9	G+0,2	E H11	Part No.	C f8	D H9	G+0,2	E H11	Part No.
10,0	18,0	6,0	13,5	WD1700100-N9	80,0	88,0	6,0	83,5	WD1700800-N9
12,0	20,0	6,0	15,5	WD1700120-N9	85,0	93,0	6,0	88,5	WD1700850-N9
14,0	22,0	6,0	17,5	WD1700140-N9	90,0	98,0	6,0	93,5	WD1700900-N9
15,0	23,0	6,0	18,5	WD1700150-N9	95,0	103,0	6,0	98,5	WD1700950-N9
16,0	24,0	6,0	19,5	WD1700160-N9	100,0	108,0	6,0	103,5	WD1701000-N9
18,0	26,0	6,0	21,5	WD1700180-N9	105,0	117,0	8,2	110,0	WD1701050-N9
20,0	28,0	6,0	23,5	WD1700200-N9	110,0	122,0	8,2	115,0	WD1701100-N9
22,0	30,0	6,0	25,5	WD1700220-N9	115,0	127,0	8,2	120,0	WD1701150-N9
25,0	33,0	6,0	28,5	WD1700250-N9	120,0	132,0	8,2	125,0	WD1701200-N9
28,0	36,0	6,0	31,5	WD1700280-N9	125,0	137,0	8,2	130,0	WD1701250-N9
30,0	38,0	6,0	33,5	WD1700300-N9	130,0	142,0	8,2	135,0	WD1701300-N9
32,0	40,0	6,0	35,5	WD1700320-N9	135,0	147,0	8,2	140,0	WD1701350-N9
36,0	44,0	6,0	39,5	WD1700360-N9	140,0	152,0	8,2	145,0	WD1701400-N9
38,0	46,0	6,0	41,5	WD1700380-N9	150,0	162,0	8,2	155,0	WD1701500-N9
40,0	48,0	6,0	43,5	WD1700400-N9	160,0	172,0	8,2	165,0	WD1701600-N9
42,0	50,0	6,0	45,5	WD1700420-N9	170,0	182,0	8,2	175,0	WD1701700-N9
45,0	53,0	6,0	48,5	WD1700450-N9	180,0	192,0	8,2	185,0	WD1701800-N9
50,0	58,0	6,0	53,5	WD1700500-N9	190,0	202,0	8,2	195,0	WD1701900-N9
55,0	63,0	6,0	58,5	WD1700550-N9	200,0	212,0	8,2	205,0	WD1702000-N9
56,0	64,0	6,0	59,5	WD1700560-N9	210,0	225,0	9,5	217,0	WD1702100-N9
60,0	68,0	6,0	63,5	WD1700600-N9	220,0	235,0	9,5	227,0	WD1702200-N9
63,0	71,0	6,0	66,5	WD1700630-N9	230,0	245,0	9,5	237,0	WD1702300-N9
65,0	73,0	6,0	68,5	WD1700650-N9	240,0	255,0	9,5	247,0	WD1702400-N9
70,0	78,0	6,0	73,5	WD1700700-N9	250,0	265,0	9,5	257,0	WD1702500-N9
75,0	83,0	6,0	78,5	WD1700750-N9	260,0	275,0	9,5	267,0	WD1702600-N9

Bold print indicates ISO 3320 sizes.



General

Description

The scraper DA 22 is a double-acting polyurethane scraper for installation in grooves to ISO 6195, Type C.

Significant improvements are achieved with respect to the profile geometry and material used compared with conventional elastomeric scrapers.

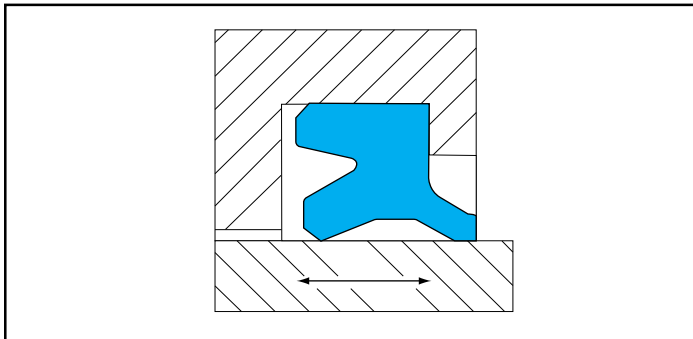

Figure 10 Scraper DA 22

The scraper lip is designed in such a way that it reliably scrapes off the dirt but leaves a residual oil film on the rod which is required for proper lubrication. The radial squeeze is sufficient to reliably remove particles, dust and water.

The scraping lip facing inward is designed such that it assumes a sealing function even under pressure. The static seal is achieved by a tight radial fit between the scraper body and the groove.

The scraper is preferably used in conjunction with rod seals, such as the Turcon® Stepseal® K or B+S U-Cup, which maintains a hydrodynamic back-pumping function.

Advantages

- Good scraping effect, even with highly adhering dirt
- Wear resistant, long service life
- Retaining and return delivery function for residual oil
- Reduced friction in combination with elastomer materials
- Standard element for standardized installation grooves

Technical Data

Pressure:	
Scraper Side:	Atmospheric pressure
Seal Side:	Pressures up to 2 MPa (290 psi) a relief bore must be provided with higher pressures
Speed:	Up to 1,0 m/s (3.0 ft/s) with reciprocating movements
Temperature:	-30°C to +100°C (-22°F to +212°F)
Media:	Mineral oils and greases, flame retardant hydraulic fluids, etc. See Table 1 page 2.

Material

The scraper is manufactured with high precision from high-grade polyester/polyurethane.

Material:	WUAQ3
Hardness, Shore A:	93± 5, measured on test specimen
Color:	Turquoise

Material:	Zurcon® Z94
Hardness, Shore A:	94± 5, measured on test specimen
Color:	Turquoise

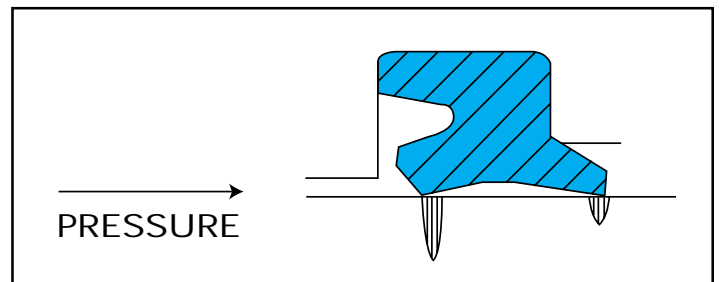

Figure 11 Scraper DA 22 load profile



DA 22 Dimensional Data

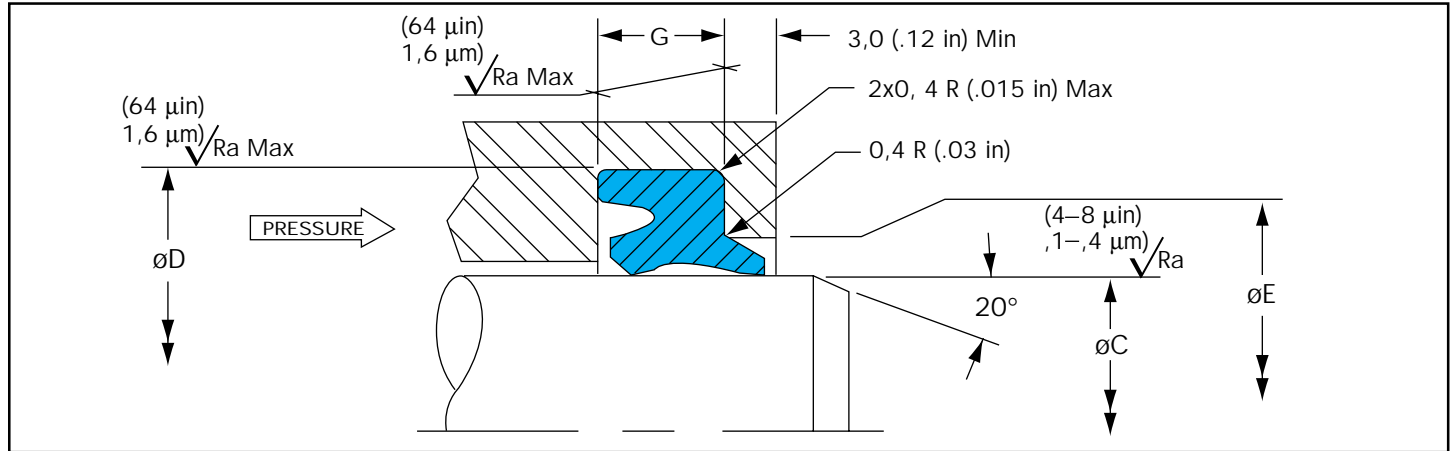

Table 18 DA 22 Ordering Information (Metric)

Rod Diameter C f8	Groove Diameter D H9	Groove Width G+0,2	Exit Diameter E H11	Part Number Polyurethane
*12,0	18,0	4,0	14,5	WD2200120-WUAQ3
*14,0	20,0	4,0	16,5	WD2200140-WUAQ3
*16,0	22,0	4,0	18,5	WD2200160-WUAQ3
*18,0	24,0	4,0	20,5	WD2200180-WUAQ3
20,0	26,0	4,0	22,5	WD2200200-WUAQ3
22,0	28,0	4,0	24,5	WD2200220-WUAQ3
25,0	31,0	4,0	27,5	WD2200250-WUAQ3
28,0	36,0	5,0	31,0	WD2200280-WUAQ3
30,0	38,0	5,0	33,0	WD2200300-WUAQ3
32,0	40,0	5,0	35,0	WD2200320-WUAQ3
36,0	44,0	5,0	39,0	WD2200360-WUAQ3
40,0	48,0	5,0	43,0	WD2200400-WUAQ3
45,0	53,0	5,0	48,0	WD2200450-WUAQ3
50,0	58,0	5,0	53,0	WD2200500-WUAQ3
55,0	65,0	6,0	58,0	WD2200550-WUAQ3
56,0	66,0	6,0	59,0	WD2200560-WUAQ3
60,0	70,0	6,0	63,0	WD2200600-WUAQ3
63,0	73,0	6,0	66,0	WD2200630-WUAQ3
70,0	80,0	6,0	73,0	WD2200700-WUAQ3
75,0	85,0	6,0	78,0	WD2200750-WUAQ3
80,0	90,0	6,0	83,0	WD2200800-WUAQ3
85,0	95,0	6,0	88,0	WD2200850-WUAQ3

The sizes in **Bold** type comply with ISO 6195, installation groove Type C.

*Split gland required for installation of sizes less than 18mm.



Table 18 DA 22 Ordering Information (Metric - Continued)

Rod Diameter C f8	Groove Diameter D H9	Groove Width G+0,2	Exit Diameter E H11	Part Number Polyurethane
90,0	100,0	6,0	93,0	WD2200900-WUAQ3
100,0	110,0	6,0	103,0	WD2201000-WUAQ3
110,0	125,0	8,5	114,0	WD2201100-WUAQ3
125,0	140,0	8,5	129,0	WD2201250-WUAQ3
140,0	155,0	8,5	144,0	WD2201400-WUAQ3
160,0	175,0	8,5	164,0	WD2201600-WUAQ3
180,0	195,0	8,5	184,0	WD2201800-WUAQ3

The sizes in **bold** type comply with ISO 6195, installation groove Type C.
Other sizes available on request.

Table 19 DA 22 Ordering Information (Imperial)

Rod Diameter C f8	Groove Diameter D H9	Groove Width G+.008	Exit Diameter E H11	Part Number Polyurethane
*0.500	0.802	.203	0.620	WDE100500-Z94
*0.625	0.927	.203	0.745	WDE100625-Z94
*0.750	1.052	.203	0.870	WDE100750-Z94
0.875	1.240	.218	1.010	WDE200875-Z94
1.000	1.365	.218	1.135	WDE201000-Z94
1.125	1.490	.218	1.260	WDE201125-Z94
1.250	1.615	.218	1.385	WDE201250-Z94
1.375	1.740	.218	1.510	WDE201375-Z94
1.500	1.865	.218	1.635	WDE201500-Z94
1.625	1.990	.218	1.760	WDE201625-Z94
1.750	2.115	.218	1.885	WDE201750-Z94
1.875	2.240	.218	2.010	WDE201875-Z94

*Split gland required for installation of sizes less than .750 inches.

Bold print indicates Busak+Shamban Preferred Design sizes.



Table 19 DA 22 Ordering Information (Imperial - Continued)

Rod Diameter	Groove Diameter	Groove Width	Exit Diameter	Part Number Polyurethane
C f8	D H9	G+.008	E H11	
2.000	2.365	.218	2.135	WDE202000-Z94
2.125	2.490	.218	2.260	WDE202125-Z94
2.250	2.745	.281	2.445	WDE302250-Z94
2.375	2.870	.281	2.570	WDE302375-Z94
2.500	2.995	.281	2.695	WDE302500-Z94
2.750	3.245	.281	2.945	WDE302750-Z94
3.000	3.495	.281	3.195	WDE303000-Z94
3.250	3.745	.281	3.445	WDE303250-Z94
3.500	3.995	.281	3.695	WDE303500-Z94
4.000	4.495	.281	4.195	WDE304000-Z94
4.500	4.995	.281	4.695	WDE304500-Z94
5.000	5.495	.281	5.195	WDE305000-Z94
5.500	5.995	.281	5.695	WDE305500-Z94
6.000	6.495	.281	6.195	WDE306000-Z94
6.500	6.995	.281	6.695	WDE306500-Z94
7.000	7.495	.281	7.195	WDE307000-Z94
7.500	7.995	.281	7.695	WDE307500-Z94
8.000	8.495	.281	8.195	WDE308000-Z94

Bold print indicates Busak+Shamban Preferred Design sizes.



■ General

Scraper rings are fitted onto axially moving rods, plungers, etc. in hydraulic cylinders. During the movement, dust particles may find their way into the hydraulic system and thus cause damage or premature wear of seals, guides and bearings.

Description

The Turcon® Excluder® 2 is comprised of a scraper ring made of Turcon® and an O-Ring as an elastic energizer. The scraper function is performed by the Excluder® ring, while the elastic O-Ring guarantees that the scraper lip presses against the sliding surface uniformly.

Advantages

- Small installation space
- Simple groove configuration
- Good wiping effect, even in the presence of stubborn dirt, ice, etc.
- No stick-slip effect during start-up; no adhesion
- Very abrasion resistant, long service life

Technical Data

Speed:	Reciprocating up to 15 m/s (50 ft/s)
Temperature:	-54°C to +200°C (-65°F to +392°F) (depending on the O-Ring compound)

Material

Turcon® is an extremely wear-resistant, specially modified PTFE material with a high degree of inherent rigidity which retains its shape under extreme conditions.

Turcon® materials are resistant to practically all chemicals. The material will only be affected by liquid sodium or potassium and, under certain conditions, by some halogen compounds (including fluorine).

Fields of Application

The Excluder® 2 is used as a scraper for rods and plungers. It is used in reciprocating motion, oscillating or helical movement applications. The primary fields include hydraulic and pneumatic equipment, servo valves, the chemical industry and the food processing industry.

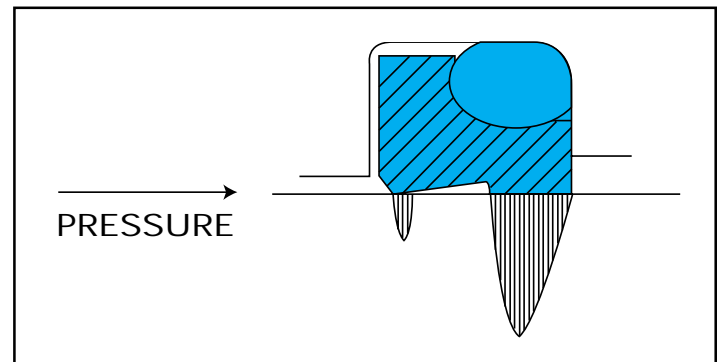

Figure 12 Turcon® Excluder® 2 load profile



Turcon® Excluder® 2 Dimensional Data

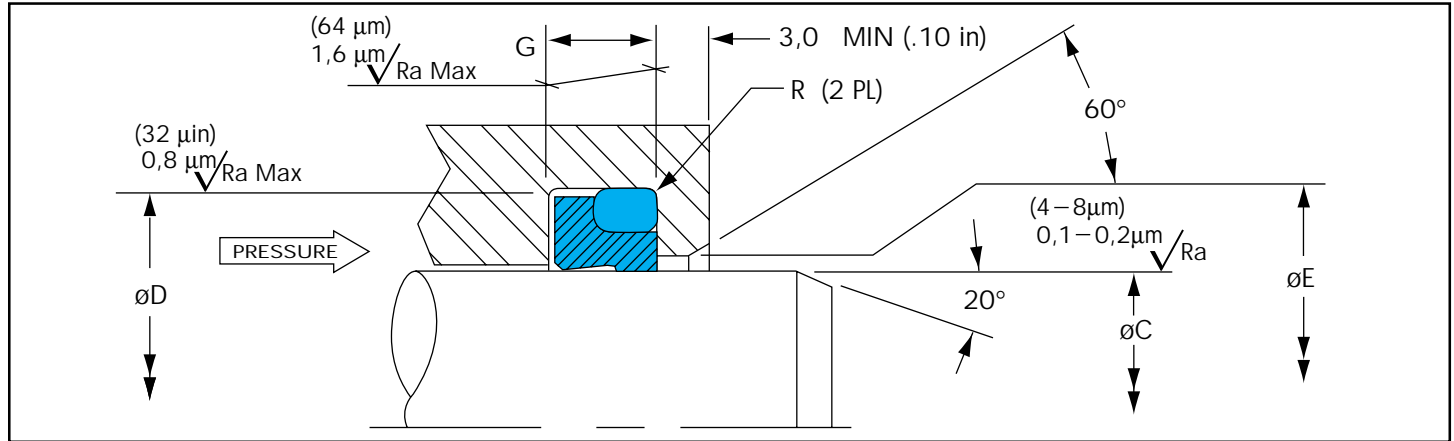

Table 20 Turcon® Excluder® 2 Ordering Information (Metric)

Rod Dia.	Groove Dia.	Groove Width	Exit Dia.	Radius	O-Ring	Turcon® Excluder®2 Turcon® T46
C f8	D H9	G+0,2	E H11	R (Max)	Dash No.	Part No.
12,0	18,8	5,0	13,5	0,7	113	WE3100120-T46
14,0	20,8	5,0	15,5	0,7	114	WE3100140-T46
15,0	21,8	5,0	16,5	0,7	115	WE3100150-T46
16,0	22,8	5,0	17,5	0,7	115	WE3100160-T46
18,0	24,8	5,0	19,5	0,7	117	WE3100180-T46
20,0	26,8	5,0	21,5	0,7	118	WE3100200-T46
22,0	28,8	5,0	23,5	0,7	119	WE3100220-T46
25,0	31,8	5,0	26,5	0,7	121	WE3100250-T46
28,0	34,8	5,0	29,5	0,7	123	WE3100280-T46
30,0	36,8	5,0	31,5	0,7	124	WE3100300-T46
32,0	38,8	5,0	33,5	0,7	126	WE3100320-T46
36,0	42,8	5,0	37,5	0,7	128	WE3100360-T46
38,0	44,8	5,0	39,5	0,7	129	WE3100380-T46
40,0	46,8	5,0	41,5	0,7	131	WE3100400-T46
42,0	48,8	5,0	43,5	0,7	132	WE3100420-T46
45,0	51,8	5,0	46,5	0,7	134	WE3100450-T46
50,0	56,8	5,0	51,5	0,7	137	WE3100500-T46
55,0	61,8	5,0	56,5	0,7	140	WE3100550-T46
56,0	62,8	5,0	57,5	0,7	141	WE3100560-T46
60,0	66,8	5,0	61,5	0,7	143	WE3100600-T46
63,0	69,8	5,0	64,5	0,7	145	WE3100630-T46
65,0	73,8	6,0	66,5	1,0	231	WE3200650-T46
70,0	78,8	6,0	71,5	1,0	233	WE3200700-T46
75,0	83,8	6,0	76,5	1,0	234	WE3200750-T46
80,0	88,8	6,0	81,5	1,0	236	WE3200800-T46

The sizes in bold type comply with ISO 3320.



Table 20 Turcon® Excluder® 2 Ordering Information (Metric - Continued)

Rod Dia.	Groove Dia.	Groove Width	Exit Dia.	Radius	O-Ring	Turcon® Excluder® 2 Turcon® T46
C f8	D H9	G+0,2	E H11	R (Max)	Dash No.	Part No.
85,0	93,8	6,0	86,5	1,0	238	WE3200850-T46
90,0	98,8	6,0	91,5	1,0	239	WE3200900-T46
95,0	103,8	6,0	96,5	1,0	241	WE3200950-T46
100,0	108,8	6,0	101,5	1,0	242	WE3201000-T46
105,0	113,8	6,0	106,5	1,0	244	WE3201050-T46
110,0	118,8	6,0	111,5	1,0	245	WE3201100-T46
115,0	123,8	6,0	116,5	1,0	247	WE3201150-T46
120,0	128,8	6,0	121,5	1,0	248	WE3201200-T46
125,0	133,8	6,0	126,5	1,0	250	WE3201250-T46
130,0	138,8	6,0	131,5	1,0	252	WE3201300-T46
135,0	143,8	6,0	136,5	1,0	253	WE3201350-T46
140,0	148,8	6,0	141,5	1,0	255	WE3201400-T46
150,0	158,8	6,0	151,5	1,0	258	WE3201500-T46
160,0	168,8	6,0	161,5	1,0	259	WE3201600-T46
170,0	178,8	6,0	171,5	1,0	261	WE3201700-T46
180,0	188,8	6,0	181,5	1,0	263	WE3201800-T46
190,0	198,8	6,0	191,5	1,0	264	WE3201900-T46
200,0	208,8	6,0	201,5	1,0	266	WE3202000-T46
210,0	218,8	6,0	211,5	1,0	267	WE3202100-T46
220,0	228,8	6,0	221,5	1,0	269	WE3202200-T46
230,0	238,8	6,0	231,5	1,0	270	WE3202300-T46
240,0	248,8	6,0	241,5	1,0	272	WE3202400-T46
250,0	258,8	6,0	251,5	1,0	274	WE3202500-T46
280,0	292,2	8,4	282,0	1,2	379	WE3302800-T46
300,0	312,2	8,4	302,0	1,2	381	WE3303000-T46
320,0	332,2	8,4	322,0	1,2	382	WE3303200-T46
350,0	362,2	8,4	352,0	1,2	383	WE3303500-T46
360,0	372,2	8,4	362,0	1,2	383	WE3303600-T46
400,0	412,2	8,4	402,0	1,2	385	WE3304000-T46
420,0	432,0	8,4	422,0	1,2	386	WE3304200-T46
440,0	456,0	11,0	442,5	1,5	464	WE3404400-T46
450,0	466,0	11,0	452,5	1,5	465	WE3404500-T46
460,0	476,0	11,0	462,5	1,5	466	WE3404600-T46
480,0	496,0	11,0	482,5	1,5	467	WE3404800-T46
500,0	516,0	11,0	502,5	1,5	468	WE3405000-T46
550,0	566,0	11,0	552,5	1,5	471	WE3405500-T46
600,0	616,0	11,0	602,5	1,5	473	WE3406000-T46
650,0	666,0	11,0	652,5	1,5	475	WE3406500-T46
700,0	720,0	14,0	702,5	2,7	8,4x715	WE3507000-T46
800,0	820,0	14,0	802,5	2,7	8,4x810	WE3508000-T46
900,0	920,0	14,0	902,5	2,7	8,4x888	WE3509000-T46
1000,0	1020,0	14,0	1002,5	2,7	8,4x1014	WE35X1000-T46

Bold indicates grooves per ISO 3320

Other dimensions and all intermediate sizes up to 2500mm diameter can be supplied.



Table 21 Turcon® Excluder® 2 Ordering Information (Imperial)

Rod Dia.	Groove Dia.	Groove Width	Exit Dia.	Radius	O-Ring	Turcon® Excluder® 2 Turcon® T46
C f8	D H9	G+.008	E H11	R (Max)	Dash No.	Part No.
0.500	0.770	.196	0.560	.015	113	WE2100500-T46
0.563	0.833	.196	0.623	.015	114	WE2100563-T46
0.625	0.895	.196	0.685	.015	115	WE2100625-T46
0.688	0.958	.196	0.748	.015	116	WE2100688-T46
0.750	1.020	.196	0.810	.015	117	WE2100750-T46
0.813	1.083	.196	0.873	.015	118	WE2100813-T46
0.875	1.145	.196	0.935	.015	119	WE2100875-T46
0.938	1.208	.196	0.998	.015	120	WE2100938-T46
1.000	1.270	.196	1.060	.015	121	WE2101000-T46
1.063	1.333	.196	1.123	.015	122	WE2101063-T46
1.125	1.395	.196	1.185	.015	123	WE2101125-T46
1.188	1.458	.196	1.248	.015	124	WE2101188-T46
1.250	1.520	.196	1.310	.015	125	WE2101250-T46
1.313	1.583	.196	1.373	.015	126	WE2101313-T46
1.375	1.645	.196	1.435	.015	127	WE2101375-T46
1.438	1.708	.196	1.498	.015	128	WE2101438-T46
1.500	1.770	.196	1.560	.015	129	WE2101500-T46
1.563	1.833	.196	1.623	.015	130	WE2101563-T46
1.625	1.895	.196	1.685	.015	131	WE2101625-T46
1.688	1.958	.196	1.748	.015	132	WE2101688-T46
1.750	2.020	.196	1.810	.015	133	WE2101750-T46
1.813	2.083	.196	1.873	.015	134	WE2101813-T46
1.875	2.145	.196	1.935	.015	135	WE2101875-T46
1.938	2.208	.196	1.998	.015	136	WE2101938-T46
2.000	2.270	.196	2.060	.015	137	WE2102000-T46
2.125	2.395	.196	2.185	.015	139	WE2102125-T46
2.250	2.520	.196	2.310	.015	141	WE2102250-T46
2.375	2.645	.196	2.435	.015	143	WE2102375-T46
2.500	2.770	.196	2.560	.015	145	WE2102500-T46
2.625	2.895	.196	2.685	.015	147	WE2102625-T46
2.750	3.020	.196	2.810	.015	149	WE2102750-T46
2.875	3.145	.196	2.935	.015	151	WE2102875-T46
3.000	3.270	.196	3.060	.015	151	WE2103000-T46
3.125	3.395	.196	3.185	.015	152	WE2103125-T46
3.250	3.520	.196	3.310	.015	152	WE2103250-T46

Bold print indicates Busak+Shamban Preferred Design sizes.



Table 21 Turcon® Excluder® 2 Ordering Information (Imperial - Continued)

Rod Dia.	Groove Dia.	Groove Width	Exit Dia.	Radius	O-Ring	Turcon® Excluder®2 Turcon® T46
C f8	D H9	G+.008	E H11	R (Max)	Dash No.	Part No.
3.375	3.645	.196	3.435	.015	153	WE2103375-T46
3.500	3.770	.196	3.560	.015	153	WE2103500-T46
3.625	3.895	.196	3.685	.015	154	WE2103625-T46
3.750	4.020	.196	3.810	.015	154	WE2103750-T46
3.875	4.145	.196	3.935	.015	155	WE2103875-T46
4.000	4.270	.196	4.060	.015	155	WE2104000-T46
4.125	4.395	.196	4.185	.015	156	WE2104125-T46
4.250	4.520	.196	4.310	.015	156	WE2104250-T46
4.375	4.645	.196	4.435	.015	157	WE2104375-T46
4.500	4.770	.196	4.560	.015	157	WE2104500-T46
4.625	4.895	.196	4.685	.015	158	WE2104625-T46
4.750	5.020	.196	4.810	.015	158	WE2104750-T46
4.875	5.145	.196	4.935	.015	159	WE2104875-T46
5.000	5.270	.196	5.060	.015	159	WE2105000-T46
5.125	5.395	.196	5.185	.015	160	WE2105125-T46
5.250	5.520	.196	5.310	.015	160	WE2105250-T46
5.375	5.645	.196	5.435	.015	161	WE2105375-T46
5.500	5.770	.196	5.560	.015	161	WE2105500-T46
5.625	5.895	.196	5.685	.015	162	WE2105625-T46
5.750	6.020	.196	5.810	.015	162	WE2105750-T46
6.000	6.345	.236	6.060	.015	258	WE2206000-T46
6.250	6.595	.236	6.310	.015	259	WE2206250-T46
6.500	6.845	.236	6.560	.015	260	WE2206500-T46
6.750	7.095	.236	6.810	.015	261	WE2206750-T46
7.000	7.345	.236	7.060	.015	262	WE2207000-T46
7.250	7.595	.236	7.310	.015	263	WE2207250-T46
7.500	7.845	.236	7.560	.015	264	WE2207500-T46
7.750	8.095	.236	7.810	.015	265	WE2207750-T46
8.000	8.345	.236	8.060	.015	266	WE2208000-T46
8.250	8.595	.236	8.310	.015	267	WE2208250-T46
8.500	8.845	.236	8.560	.015	268	WE2208500-T46
8.750	9.095	.236	8.810	.015	269	WE2208750-T46
9.000	9.345	.236	9.060	.015	270	WE2209000-T46
9.250	9.595	.236	9.310	.015	271	WE2209250-T46
9.500	9.845	.236	9.560	.015	272	WE2209500-T46

Bold print indicates Busak+Shamban Preferred Design sizes.



Table 21 Turcon® Excluder® 2 Ordering Information (Imperial - Continued)

Rod Dia.	Groove Dia.	Groove Width	Exit Dia.	Radius	O-Ring	Turcon® Excluder®2 Turcon® T46
C f8	D H9	G+.008	E H11	R (Max)	Dash No.	Part No.
9.750	10.095	.236	9.810	.015	273	WE2209750-T46
10.000	10.480	.332	10.080	.035	377	WE2310000-T46
10.500	10.980	.332	10.580	.035	378	WE2310500-T46
11.000	11.480	.332	11.080	.035	379	WE2311000-T46
11.500	11.980	.332	11.580	.035	380	WE2311500-T46
12.000	12.480	.332	12.080	.035	381	WE2312000-T46
12.500	12.980	.332	12.580	.035	381	WE2312500-T46
13.000	13.480	.332	13.080	.035	382	WE2313000-T46
13.500	13.980	.332	13.580	.035	382	WE2313500-T46
14.000	14.480	.332	14.080	.035	383	WE2314000-T46
14.500	14.980	.332	14.580	.035	383	WE2314500-T46
15.000	15.480	.332	15.080	.035	384	WE2315000-T46
15.500	15.980	.332	15.580	.035	384	WE2315500-T46
16.000	16.480	.332	16.080	.035	385	WE2316000-T46
16.500	16.980	.332	16.580	.035	385	WE2316500-T46
17.000	17.630	.434	17.080	.035	463	WE2417000-T46
17.500	18.130	.434	17.580	.035	464	WE2417500-T46
18.000	18.630	.434	18.080	.035	465	WE2418000-T46
18.500	19.130	.434	18.580	.035	466	WE2418500-T46
19.000	19.630	.434	19.080	.035	467	WE2419000-T46
19.500	20.130	.434	19.580	.035	468	WE2419500-T46
20.000	20.630	.434	20.080	.035	469	WE2420000-T46

Bold print indicates Busak+Shamban Preferred Design sizes.

The matching O-Ring may have larger or smaller OD than the groove diameter. However, the difference shall not affect the performance and reliability of the scraper once the Excluder® 2 is installed properly.

Ordering Example

Turcon® Excluder® 2

Rod Diameter: C = 50.0 mm
 Series: WE31 (from table 20)
 Part No.: WE3100500 (from table 20)

Select the material from Table 1, page 2. The corresponding code numbers are appended to the Part No. Together they form the Order Number. For all intermediate sizes not shown from the example opposite. Order O-Ring separately.

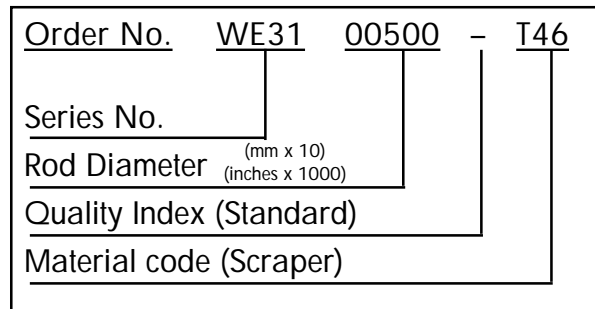



General

The Turcon® Excluder® 5 is a patented (patent No. EP 023 5568) double-acting scraper with two geometrically different scraper lips which are installed back-to-back. The scraper is installed together with an O-Ring as an elastic energizing element in one groove. The scraper function is performed by the Excluder® 5. The O-Ring maintains the pressure of the scraper lips against the sliding surface and can compensate some deflections of the piston rod.

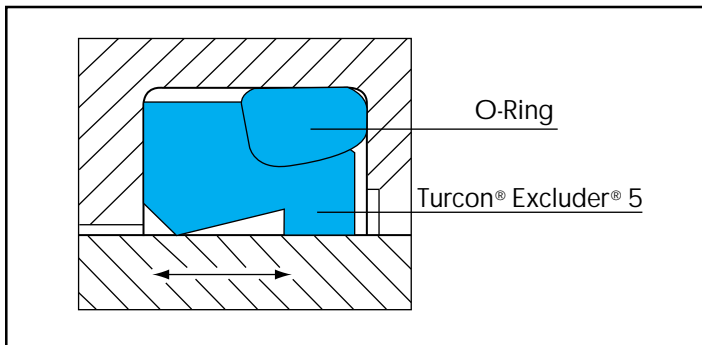

Figure 13 Turcon® Excluder® 5

Turcon® Excluder® 5 has a double function:

- To scrape off contaminants from the retracting piston rod and thus to protect the system from soiling, and
- To hold back the residual oil film on the extending piston rod on the medium side.

Turcon® Excluder® 5 is preferably used in conjunction with our rod seal Turcon® Stepseal® K, i.e. a seal with a hydrodynamic back-pumping function. In contrast to the Turcon® Excluder® 2, it is used particularly for heavy-duty applications such as in construction machinery, presses, etc.

Advantages

- Outstanding sliding properties
- Stick-slip-free, no sticking
- Tough scraper for heavy-duty operation
- Can compensate for relatively large deflections of the piston rod or plunger
- Very good scraping effect even against firmly adhered dirt, etc.

- Very good scraping effect from the inside against the residual oil film adhering to the surface of the piston rod
- Identical installation with that of the Turcon® Excluder® 500
- Very high chemical resistance to hydraulic media
- Available for all diameters up to 2.500 mm

Technical Data

Speed:	15 m/s (50 ft/s) for Turcon® materials 2 m/s (6.5ft/s) for Zurcon® materials with reciprocating movements
Temperature:	-54°C to +200°C (Turcon®) (-65°F to +392°F) -30°C to +110°C (Zurcon®) (-22°F to +230°F)
Media:	Mineral oil-based hydraulic fluids, flame retardant hydraulic fluids, environmentally safe hydraulic fluids (bio-oils), water, air and others, depending on the O-Ring material.

Material

The following material combination has proven effective for most applications:

Excluder® 5:	Turcon® T46
O-Ring:	Acrylonitrile butadiene rubber NBR, 70 Shore A Material No. N7038

For specific applications, other material combinations as listed in Table 1, page 2 may also be used.

Design and Installation Instructions

Excluder® 5 scrapers can be installed in split and closed grooves.

Installation in closed grooves is dependent on the rod diameter, profile cross-section of the scraper and on the cross-section of the corresponding O-Ring.



Turcon® Excluder® 5 Dimensional Data

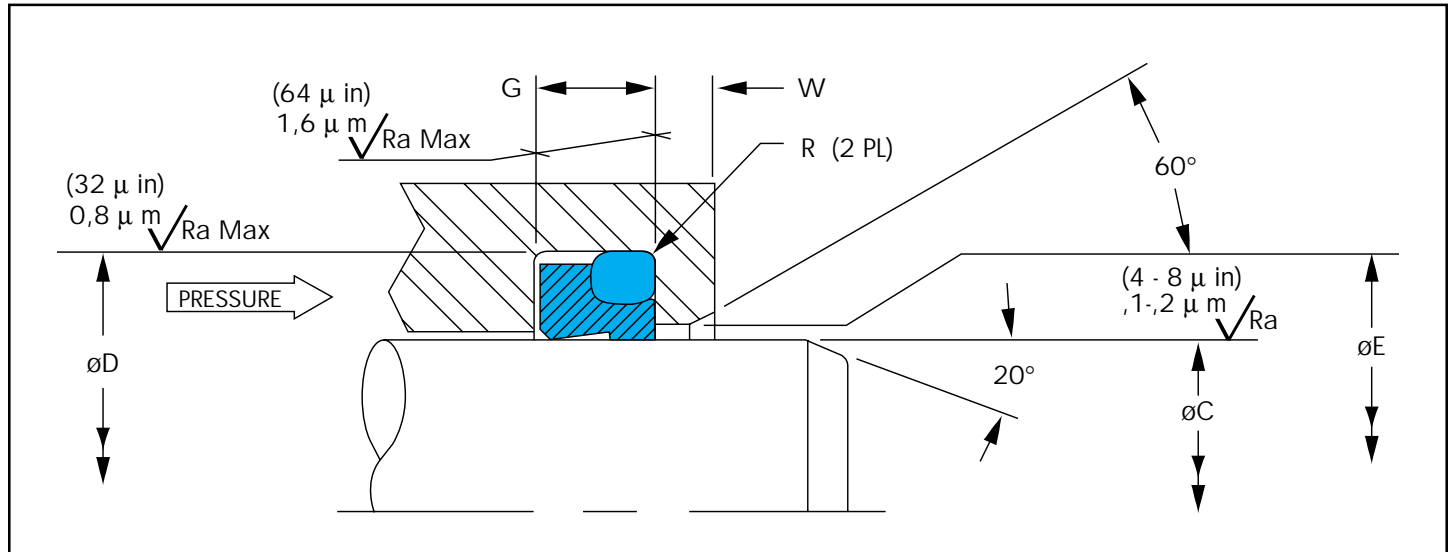

Table 22 Turcon® Excluder® 5 Installation Dimensions (Metric)

Rod Diameter C f8	Groove Diameter D H9	Groove Width G+0,2	Exit Diameter E H11	Step Width W min.	O-Ring Dash No.	Radius R (Max)	Turcon® Excluder® 5 Part No.
20,0	27,6	4,2	21,5	3,0	118	0,4	WE5000200-T46
22,0	29,6	4,2	23,5	3,0	120	0,4	WE5000220-T46
25,0	32,6	4,2	26,5	3,0	122	0,4	WE5000250-T46
28,0	35,6	4,2	29,5	3,0	123	0,4	WE5000280-T46
30,0	37,6	4,2	31,5	3,0	125	0,4	WE5000300-T46
32,0	39,6	4,2	33,5	3,0	126	0,4	WE5000320-T46
35,0	42,6	4,2	36,5	3,0	128	0,4	WE5000350-T46
36,0	43,6	4,2	37,5	3,0	129	0,4	WE5000360-T46
40,0	48,8	6,3	41,5	3,0	132	0,7	WE5100400-T46
42,0	50,8	6,3	43,5	3,0	133	0,7	WE5100420-T46
45,0	53,8	6,3	46,5	3,0	135	0,7	WE5100450-T46
48,0	56,8	6,3	49,5	3,0	137	0,7	WE5100480-T46
50,0	58,8	6,3	51,5	3,0	138	0,7	WE5100500-T46
52,0	60,8	6,3	53,5	3,0	139	0,7	WE5100520-T46
55,0	63,8	6,3	56,5	3,0	141	0,7	WE5100550-T46
56,0	64,8	6,3	57,5	3,0	142	0,7	WE5100560-T46
60,0	68,8	6,3	61,5	3,0	144	0,7	WE5100600-T46
63,0	71,8	6,3	64,5	3,0	146	0,7	WE5100630-T46
65,0	73,8	6,3	66,5	3,0	147	0,7	WE5100650-T46
70,0	82,2	8,1	72,0	4,0	234	1,0	WE5200700-T46

The sizes in bold type comply with ISO 3320.



Table 22 Turcon® Excluder® 5 Ordering Information (Metric - Continued)

Rod Diameter C f8	Groove Diameter D H9	Groove Width G+0,2	Exit Diameter E H11	Step Width W min.	O-Ring Dash No.	Radius R (Max)	Turcon® Excluder® 5 Part No.
75,0	87,2	8,1	77,0	4,0	235	1,0	WE5200750-T46
80,0	92,2	8,1	82,0	4,0	237	1,0	WE5200800-T46
85,0	97,2	8,1	87,0	4,0	239	1,0	WE5200850-T46
90,0	102,2	8,1	92,0	4,0	240	1,0	WE5200900-T46
95,0	107,2	8,1	97,0	4,0	242	1,0	WE5200950-T46
100,0	112,2	8,1	102,0	4,0	243	1,0	WE5201000-T46
105,0	117,2	8,1	107,0	4,0	245	1,0	WE5201050-T46
110,0	122,2	8,1	112,0	4,0	246	1,0	WE5201100-T46
115,0	127,2	8,1	117,0	4,0	248	1,0	WE5201150-T46
120,0	132,2	8,1	122,0	4,0	249	1,0	WE5201200-T46
125,0	137,2	8,1	127,0	4,0	251	1,0	WE5201250-T46
130,0	142,2	8,1	132,0	4,0	253	1,0	WE5201300-T46
135,0	147,2	8,1	137,0	4,0	254	1,0	WE5201350-T46
140,0	156,0	9,5	142,5	5,0	359	1,2	WE5301400-T46
150,0	166,0	9,5	152,5	5,0	361	1,2	WE5301500-T46
160,0	176,0	9,5	162,5	5,0	363	1,2	WE5301600-T46
170,0	186,0	9,5	172,5	5,0	365	1,2	WE5301700-T46
180,0	196,0	9,5	182,5	5,0	366	1,2	WE5301800-T46
190,0	206,0	9,5	192,5	5,0	368	1,2	WE5301900-T46
200,0	216,0	9,5	202,5	5,0	369	1,2	WE5302000-T46
210,0	226,0	9,5	212,5	5,0	371	1,2	WE5302100-T46
220,0	236,0	9,5	222,5	5,0	373	1,2	WE5302200-T46
230,0	246,0	9,5	232,5	5,0	374	1,2	WE5302300-T46
240,0	256,0	9,5	242,5	5,0	376	1,2	WE5302400-T46
250,0	266,0	9,5	252,5	5,0	377	1,2	WE5302500-T46
260,0	276,0	9,5	262,5	5,0	378	1,2	WE5302600-T46
280,0	296,0	9,5	282,5	5,0	379	1,2	WE5302800-T46
300,0	316,0	9,5	302,5	5,0	381	1,2	WE5303000-T46
320,0	336,0	9,5	322,5	5,0	382	1,2	WE5303200-T46
350,0	366,0	9,5	352,5	5,0	383	1,2	WE5303500-T46
360,0	376,0	9,5	362,5	5,0	383	1,2	WE5303600-T46
400,0	424,0	14,0	402,5	8,0	461	1,5	WE5404000-T46
500,0	524,0	14,0	502,5	8,0	469	1,5	WE5405000-T46
600,0	624,0	14,0	602,5	8,0	473	1,5	WE5406000-T46

The sizes in **bold** type comply with ISO 3320.



The matching O-Ring may have larger or smaller OD than the groove diameter. However, the difference shall not affect the performance and reliability of the scraper once the Excluder® 5 is installed properly.

Ordering Example

Rod Diameter: C = 50.0 mm
Series: WE51 (from Table 22)
Part No.: WE5100500 (from Table 22)

Select the material from Table 1, page 2. The corresponding code numbers are appended to the Part No. Together they form the Order Number.

Notes:

- (1) Tolerances used are per ISO-286 ISO System of limits and fits.
- (2) Order O-Ring separately.

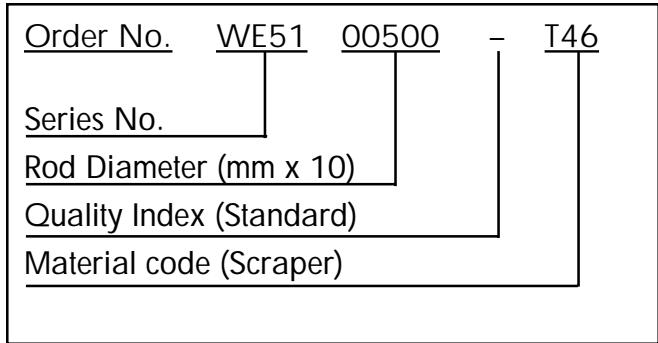



■ Description

The V-Seal is a rubber-elastic axially acting shaft seal for pressure-free sealing. Figure 14 shows the structure of the seal with the main functional elements:

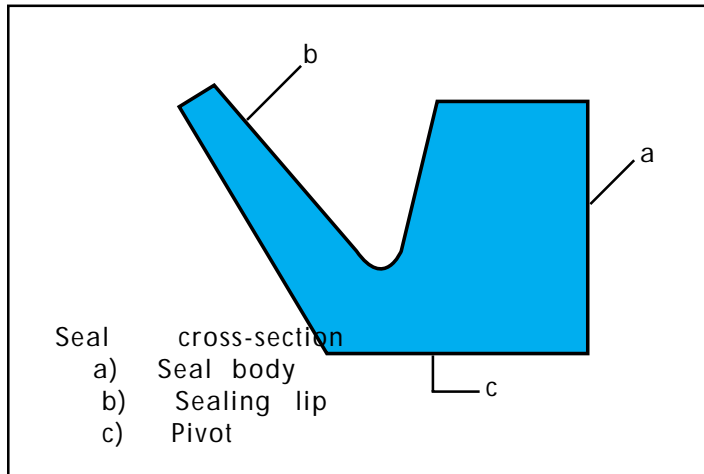

Figure 14 Functional elements of the V-Seal

The Seal Body

The seal body ensures the reliable elastomeric squeeze of the seal on the shaft. Normally the seal rotates with the shaft.

The Sealing Lip

The moving conical sealing lip contacts the normally static mating surface axially. It compensates for angular deviations and seals reliably against the mating surface.

The Pivot

The pivot represents the spring-like connection between the seal body and the sealing lip. It ensures a constant elastic mobility of the sealing lip to give a slight contact pressure on the mating surface.

Characteristics

The principal characteristic of the V-Seal is the axially acting sealing lip. In contrast to conventional shaft seals, the V-Seal seals in an axial direction.

The mobility and adaptability of the sealing lip allows compensation for larger tolerances and angular deviations more than with any other sealing elements.

The V-Seal can be used as an O.E.M. production seal or as an individual seal for refits and repairs.

Method of Operation

The V-Seal is stretched onto the shaft and is held in position by its intrinsic elastic stretch. The flexible sealing lip contacts the stationary sealing surface with a slight contact force. The sealing surface is perpendicular to the shaft axis. The flexible sealing lip compensates for tolerances, misalignment or angular deviations.

The seal lip prevents the escape of grease or oil from the inside, and protects against water splash or dust from the outside. Due to the centrifugal force, the outer seal body acts as a sling ring and prevents the ingress of dirt (Figure 15).

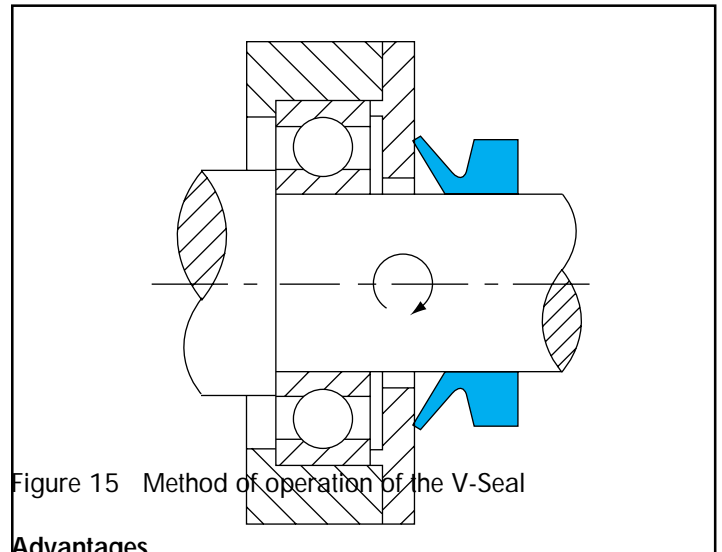

Figure 15 Method of operation of the V-Seal

Advantages

- An effective, low cost shaft seal
- No metal parts, pure rubber-elastic material
- minimum design work necessary, no installation machining required
- Eliminates demands on the machining and surface quality or hardness of the shaft
- Simple installation
- No shaft wear
- Mating surface may be left unhardened
- Minimum friction, low frictional losses, long service life
- Simultaneous function as a seal and dirt repellent
- Suitable for high speeds



Applications

Fields of Application

The ease of use and reliable function combined with minimum design requirements gives the V-Seal a wide range of applications for industrial engineering, water treatment plants, rolling mills, machine tools, etc.

The smaller seal sizes are often used in household and electrical appliances and electric motors.

V-Seals can be used for sealing against dust, dirt, lubricating grease, splash oil, water and other media.

In special cases the seal can also be used as a static seal, i.e. mounted on the stationary part.

Seal Types

The VA type seal is the most frequently used profile. This type is available as a standard for shaft diameters from 3 to 1200mm. The diameter range is split into nine profile sizes.

Larger diameters up to 2000 mm can be produced by butting vulcanizing several ring segments.

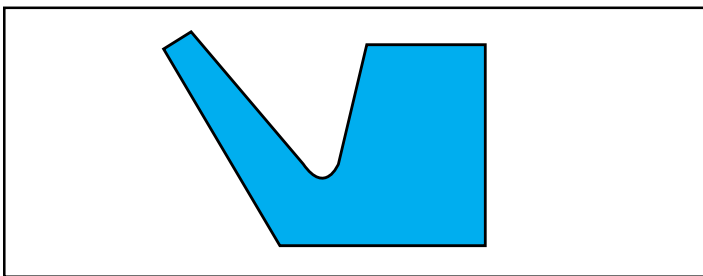

Figure 16 Standard VA Seal type

Technical Data

Operating pressure: atmospheric

Velocities:

Normal application: ≤ 8 m/s (25.6 ft/s)

Axially secured: ≥ 8 m/s (25.6 ft/s)

Axially and radially secured: ≥ 12 m/s (39 ft/s)

Temperature:

- 40°C to +180°C (-40°F to 356°F)–depending on the elastomer material

Protection Classes:

Seal of elastomer materials with V-Seals conform to protection class IP 55.

Friction

The low contact pressure of the sealing lip ensures low frictional losses. They can be influenced by greater or lesser contact force. The installation dimensions in our table refer to standard applications. The starting torque is considerably lower than that of radial shaft seal.

The frictional losses are influenced by the peripheral speed. With increasing peripheral speed, the frictional losses increase up to approximately 12 m/s (39 ft/s). Above this speed, the high centrifugal forces relieve the sealing lip.

The power losses can be seen in Figure 17.

Reducing Friction

Busak+Shamban V-Seals of Nitrile Rubber (NBR) are subjected to surface treatment in a special process. This anti-friction (AF) treatment reduces the friction by an additional 40 to 50% compared with untreated V-Seals.

This offers the user the following added advantages:

- Low starting torques
- No stick-slip effects even after prolonged inactivity
- Increased service life
- High dry running reliability

The AF treatment cannot be used when V-Seals are used in special applications, e.g. as suction units for transport and positioning facilities.

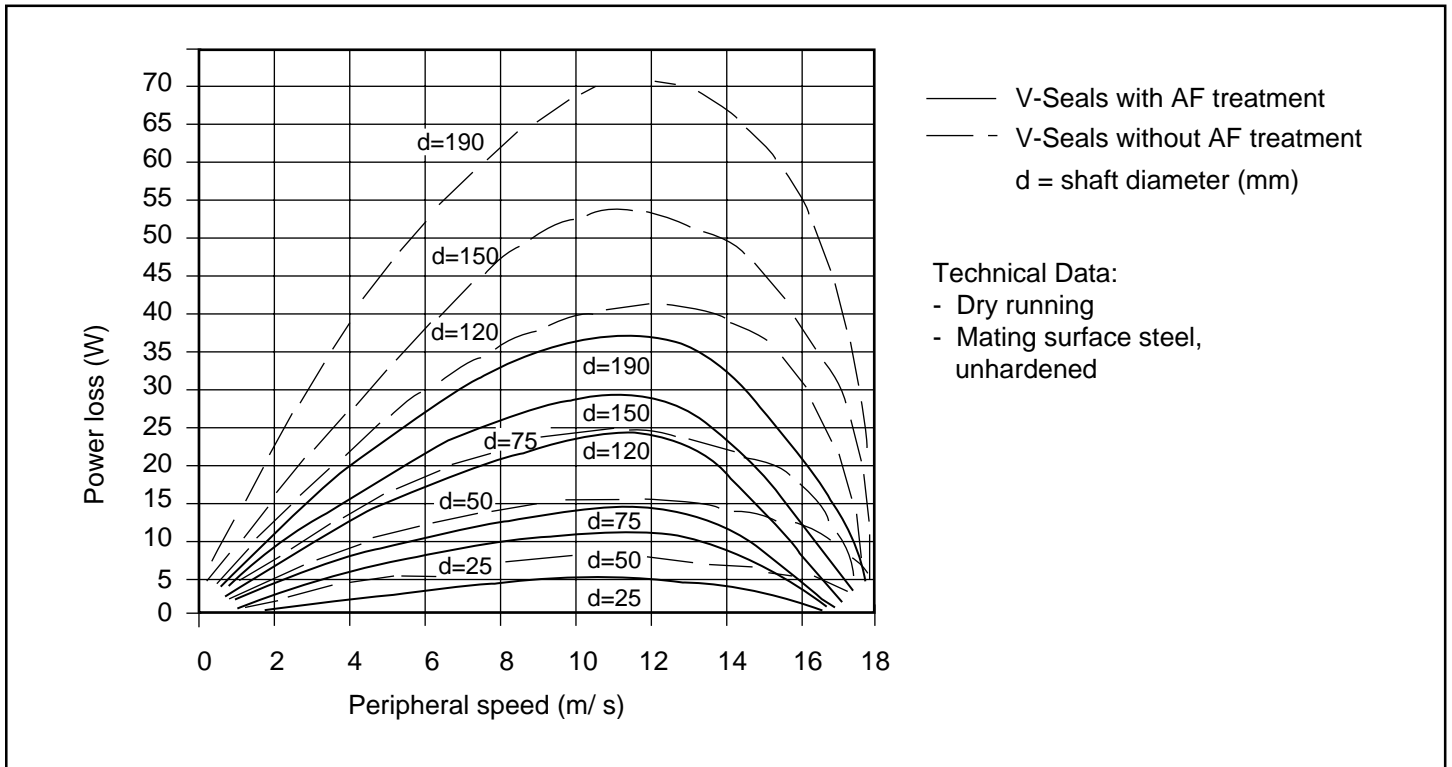

Figure 17 Power loss as a function of peripheral speed for various sizes

Materials

V-Seals are supplied as standard in two material grades:

Nitrile Rubber (NBR) in 60 Shore A, AF treated as standard

Material No.: N60
 Temperature: -40°C to +100°C (-40°F to 212°F)
 Media: Mineral oils, air, water, emulsions, greases

Fluoroelastomer (FPM), 65 Shore A

Material No.: VDO
 Temperature: -20°C to +180°C (-4°F to 356°F)
 Media: Mineral and synthetic oils and greases, acids, lyes

Other materials on request.

Design Instructions

Choice of the Seal Ring

The choice of seal sizes can be made from the table Ordering Information. (Table 23, page 71)

The V-Seal size can always be selected for one diameter range. If the nominal diameter of the shaft lies in the boundary range between two recommendations, the next larger V-Seal should be used.

The torque is transmitted by the intrinsic elastic stretch of the ring on the shaft.

Design of the Mating Surface

All components against which the V-Seal is to seal can serve as the mating surface, for example

- The face of a roller bearing
- A shaft collar
- A thrust washer



The mating surface does not require hardening. With highly abrasive materials such as sand, dirt or scale, however, a hard mating surface is beneficial.

A suitable surface can be achieved by precision machining. The surface should have no radial or spiral machining grooves. For critical applications such as high velocities, radial deflection, low friction or severe soiling, the surface quality should be approximately:

$R_{max.}$	= 10,0 - 16,0 μm
R_z	= 6,3 - 10,0 μm
R_a	= 1,6 - 3,2 μm

Installation Instructions

With the exception of special seals, V-Seals require no particular preparation for installation, nor are installation bevels or other design measures necessary.

During installation, the V-Seal can be stretched up to 20%, and may be drawn over a shaft or thrust washer. No sharp tools should be used for installation.

In order to bring the V-Seal into its working position, turn the shaft and push or center the seal body with a blunt object until it reaches its installation position.

For series-production installation, simple tools are sufficient to bring the seal into the correct installation position.

Where large-diameter seals are to be installed, several fitters may be necessary as the stretching of large cross-sections requires considerable force.

Butt-vulcanized seals must not be stretched at the joint.

If, in the case of a repair, the installation of a closed ring is not possible or very time-consuming and expensive, it may be possible to seal a butt joint on site. Please contact us. We will be glad to help you.

Installation Recommendations Type VA

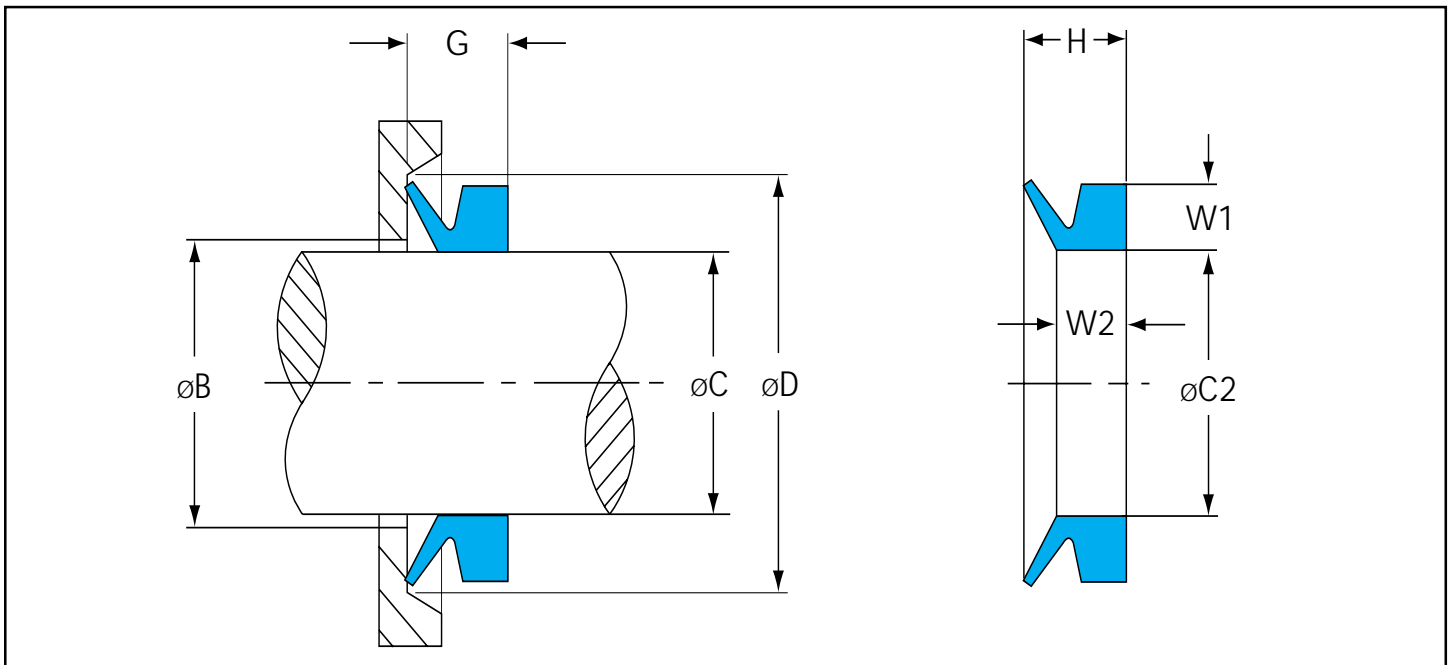

Figure 18 Installation drawing



Table 23 Ordering Information (Metric)

Shaft C Diameter Range	B Max	D Min	Installation width G	Ring Diameter C2	Profile Height W1	Profile Width H	Width W2	Part No.
2,7-3,4	C+1	C+4	2,5±0,3	2,5	1,5	3,0	2,1	TWVA00030
3,5-4,4	C+1	C+6	3,0±0,4	3,2	2,0	3,7	2,4	TWVA00040
4,5-5,4	C+1	C+6	3,0±0,4	4,0	2,0	3,7	2,4	TWVA00050
5,5-6,4	C+1	C+6	3,0±0,4	5,0	2,0	3,7	2,4	TWVA00060
6,5-7,5	C+1	C+6	3,0±0,4	6,0	2,0	3,7	2,4	TWVA00070
8,0-9,0	C+1	C+6	3,0±0,4	7,0	2,0	3,7	2,4	TWVA00080
9,5-11,0	C+2	C+9	4,5±0,6	9,0	3,0	5,5	3,4	TWVA00100
11,5-12,0	C+2	C+9	4,5±0,6	10,5	3,0	5,5	3,4	TWVA00120
13,5-15,0	C+2	C+9	4,5±0,6	12,5	3,0	5,5	3,4	TWVA00140
15,5-17,0	C+2	C+9	4,5±0,6	14,0	3,0	5,5	3,4	TWVA00160
17,5-18,5	C+2	C+9	4,5±0,6	16,0	3,0	5,5	3,4	TWVA00180
19,0-20,5	C+2	C+12	6,0±0,8	18,0	4,0	7,5	4,7	TWVA00200
21,0-23,5	C+2	C+12	6,0±0,8	20,0	4,0	7,5	4,7	TWVA00220
24,0-26,5	C+2	C+12	6,0±0,8	22,0	4,0	7,5	4,7	TWVA00250
27,0-28,5	C+2	C+12	6,0±0,8	25,0	4,0	7,5	4,7	TWVA00280
29,0-30,5	C+3	C+12	6,0±0,8	27,0	4,0	7,5	4,7	TWVA00300
31,0-32,5	C+3	C+12	6,0±0,8	29,0	4,0	7,5	4,7	TWVA00320
33,0-35,5	C+3	C+12	6,0±0,8	31,0	4,0	7,5	4,7	TWVA00350
36,0-37,5	C+3	C+12	6,0±0,8	34,0	4,0	7,5	4,7	TWVA00380
38,0-42,0	C+3	C+15	7,0±1,0	36,0	5,0	9,0	5,5	TWVA00400
43,0-47,0	C+3	C+15	7,0±1,0	40,0	5,0	9,0	5,5	TWVA00450
48,0-52,0	C+3	C+15	7,0±1,0	45,0	5,0	9,0	5,5	TWVA00500
53,0-57,0	C+3	C+15	7,0±1,0	49,0	5,0	9,0	5,5	TWVA00550
58,0-62,0	C+3	C+15	7,0±1,0	54,0	5,0	9,0	5,5	TWVA00600
63,0-67,0	C+3	C+15	7,0±1,0	58,0	5,0	9,0	5,5	TWVA00650
68,0-72,0	C+4	C+18	9,0±1,2	63,0	6,0	11,0	6,8	TWVA00700
73,0-77,0	C+4	C+18	9,0±1,2	67,0	6,0	11,0	6,8	TWVA00750
78,0-82,0	C+4	C+18	9,0±1,2	72,0	6,0	11,0	6,8	TWVA00800
83,0-87,0	C+4	C+18	9,0±1,2	76,0	6,0	11,0	6,8	TWVA00850
88,0-92,0	C+4	C+18	9,0±1,2	81,0	6,0	11,0	6,8	TWVA00900
93,0-97,0	C+4	C+18	9,0±1,2	85,0	6,0	11,0	6,8	TWVA00950
98,0-104,0	C+4	C+18	9,0±1,2	90,0	6,0	11,0	6,8	TWVA01000
105,0-114,0	C+4	C+21	10,5±1,5	99,0	7,0	12,8	7,9	TWVA01100
115,0-124,0	C+4	C+21	10,5±1,5	108,0	7,0	12,8	7,9	TWVA01200
125,0-134,0	C+4	C+21	10,5±1,5	117,0	7,0	12,8	7,9	TWVA01300



Table 23 Ordering Information (Metric - Continued)

Shaft C Diameter Range	B Max	D Min	Installation width G	Ring Diameter C2	Profile Height W1	Profile Width H	Width W2	Part No.
135,0-144,0	C+4	C+21	10,5±1,5	126,0	7,0	12,8	7,9	TWVA01400
145,0-154,0	C+4	C+21	10,5±1,5	135,0	7,0	12,8	7,9	TWVA01500
155,0-164,0	C+5	C+24	12,0±1,8	144,0	8,0	14,5	9,0	TWVA01600
165,0-174,0	C+5	C+24	12,0±1,8	153,0	8,0	14,5	9,0	TWVA01700
175,0-184,0	C+5	C+24	12,0±1,8	162,0	8,0	14,5	9,0	TWVA01800
185,0-194,0	C+5	C+24	12,0±1,8	171,0	8,0	14,5	9,0	TWVA01900
195,0-189,0	C+5	C+24	12,0±1,8	180,0	8,0	14,5	9,0	TWVA01990
190,0-209,0	C+10	C+45	20,0±4,0	180,0	15,0	25,0	14,3	TWVA02000
210,0-234,0	C+10	C+45	20,0±4,0	198,0	15,0	25,0	14,3	TWVA02200
235,0-264,0	C+10	C+45	20,0±4,0	225,0	15,0	25,0	14,3	TWVA02500
265,0-289,0	C+10	C+45	20,0±4,0	247,0	15,0	25,0	14,3	TWVA02750
290,0-309,0	C+10	C+45	20,0±4,0	270,0	15,0	25,0	14,3	TWVA03000
310,0-334,0	C+10	C+45	20,0±4,0	292,0	15,0	25,0	14,3	TWVA03250
335,0-364,0	C+10	C+45	20,0±4,0	315,0	15,0	25,0	14,3	TWVA03500
365,0-389,0	C+10	C+45	20,0±4,0	337,0	15,0	25,0	14,3	TWVA03750
390,0-429,0	C+10	C+45	20,0±4,0	360,0	15,0	25,0	14,3	TWVA04000
430,0-479,0	C+10	C+45	20,0±4,0	405,0	15,0	25,0	14,3	TWVA04500
480,0-529,0	C+10	C+45	20,0±4,0	450,0	15,0	25,0	14,3	TWVA05000
530,0-579,0	C+10	C+45	20,0±4,0	495,0	15,0	25,0	14,3	TWVA05500
580,0-629,0	C+10	C+45	20,0±4,0	540,0	15,0	25,0	14,3	TWVA06000
630,0-664,0	C+10	C+45	20,0±4,0	600,0	15,0	25,0	14,3	TWVA06500
665,0-704,0	C+10	C+45	20,0±4,0	630,0	15,0	25,0	14,3	TWVA07000
705,0-744,0	C+10	C+45	20,0±4,0	670,0	15,0	25,0	14,3	TWVA07250
745,0-784,0	C+10	C+45	20,0±4,0	705,0	15,0	25,0	14,3	TWVA07500
785,0-829,0	C+10	C+45	20,0±4,0	745,0	15,0	25,0	14,3	TWVA08000
830,0-874,0	C+10	C+45	20,0±4,0	785,0	15,0	25,0	14,3	TWVA08500
875,0-919,0	C+10	C+45	20,0±4,0	825,0	15,0	25,0	14,3	TWVA09000
920,0-964,0	C+10	C+45	20,0±4,0	865,0	15,0	25,0	14,3	TWVA09500
965,0-1010,0	C+10	C+45	20,0±4,0	910,0	15,0	25,0	14,3	TWVAX1000*
1015,0-1060,0	C+10	C+45	20,0±4,0	955,0	15,0	25,0	14,3	TWVAX1050*
1065,0-1110,0	C+10	C+45	20,0±4,0	1000,0	15,0	25,0	14,3	TWVAX1100*
1115,0-1160,0	C+10	C+45	20,0±4,0	1045,0	15,0	25,0	14,3	TWVAX1150*
1165,0-1210,0	C+10	C+45	20,0±4,0	1090,0	15,0	25,0	14,3	TWVA01200
1215,0-1260,0	C+10	C+45	20,0±4,0	1135,0	15,0	25,0	14,3	TWVA01250
1270,0-1310,0	C+10	C+45	20,0±4,0	1180,0	15,0	25,0	14,3	TWVAX1300*



Table 23 Ordering Information (Metric - Continued)

Shaft C Diameter Range	B Max	D Min	Installation width G	Ring Diameter C2	Profile Height W1	Profile Width H	Width W2	Part No.
1320,0-1360,0	C+10	C+45	20,0±4,0	1225,0	15,0	25,0	14,3	TWVAX1350*
1370,0-1410,0	C+10	C+45	20,0±4,0	1270,0	15,0	25,0	14,3	TWVAX1400*
1420,0-1460,0	C+10	C+45	20,0±4,0	1315,0	15,0	25,0	14,3	TWVAX1450*
1470,0-1510,0	C+10	C+45	20,0±4,0	1360,0	15,0	25,0	14,3	TWVAX1500*
1520,0-1560,0	C+10	C+45	20,0±4,0	1405,0	15,0	25,0	14,3	TWVAX1550*
1570,0-1610,0	C+10	C+45	20,0±4,0	1450,0	15,0	25,0	14,3	TWVAX1600*
1620,0-1660,0	C+10	C+45	20,0±4,0	1495,0	15,0	25,0	14,3	TWVAX1650*
1670,0-1710,0	C+10	C+45	20,0±4,0	1540,0	15,0	25,0	14,3	TWVAX1700*
1720,0-1760,0	C+10	C+45	20,0±4,0	1585,0	15,0	25,0	14,3	TWVAX1750*
1770,0-1810,0	C+10	C+45	20,0±4,0	1630,0	15,0	25,0	14,3	TWVAX1800*
1820,0-1860,0	C+10	C+45	20,0±4,0	1675,0	15,0	25,0	14,3	TWVAX1850*
1870,0-1910,0	C+10	C+45	20,0±4,0	1720,0	15,0	25,0	14,3	TWVAX1900*
1920,0-1960,0	C+10	C+45	20,0±4,0	1765,0	15,0	25,0	14,3	TWVAX1950*
1970,0-2010,0	C+10	C+45	20,0±4,0	1810,0	15,0	25,0	14,3	TWVAX2000*

*Available only in butt-vulcanized form. Where butt-vulcanized seals are used, reduced application parameters may have to be taken into consideration. In critical cases, please contact us.

Ordering Example

V-Seal, Type VA
 for shaft diameter = 30,0 mm
 Material: NBR (Nitrile Rubber, 60 Shore A)
 with Anti-friction (AF) treatment

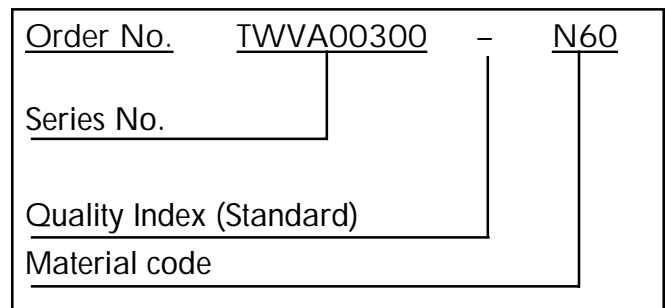



■ General

The X-Sel® QUAD-RING® Seal is a four-lip seal used and handled much like O-Rings. But where O-Rings have drawbacks, the X-Sel® QUAD-RING® Seal achieves a substantially more efficient seal. Application ranges are extensive due to the many types of synthetic rubber available today.

This section deals mainly with rotary applications. For reciprocating applications, please refer to the QUAD-RING® section under Basic Seals.

Advantages

The QUAD-RING® Seal has several advantages over O-Rings:

- No likelihood of twisting from reciprocating motion
- Less friction because it requires less radial pre-stressing which lessens contact pressure
- Less leakage because contact pressure is evenly distributed
- No interfering flash because the mold parting line is located between the lips affecting the seal
- Long life and better sealing in dynamic applications

Fields of Application

The QUAD-RING® Seal can be used in either dynamic or static applications. However, it is most often used for slow dynamic or rotary applications since the O-Ring is more economical for static applications.

- **Dynamic seals** : for reciprocating pistons, rods, plungers, etc., and for shafts, spindles, etc. subjected to slewing, spiral and rotary motion
- **Static seals** : radial and axial seals for bushings, flanges, covers, etc.

Operating Ranges

- Pressure: up to approximately 40 MPa (together with PTFE back-up rings)
- Speed: 0,5 m/s continuous up to 2,0 m/s(6.6 ft/s) briefly.
- Temperature: approx. -30°C to +80°C (-22°F to +176° F)

© QUAD-RING is a registered trademark of Quadion Corporation

Method of Operation

The QUAD-RING® Seal is a pressure energized, double-acting seal. It is a circular ring with an almost square cross section which is produced by vulcanizing in the mold. Radial and axial force are dependent upon the system pressure. The result is an increase in the compression of the seal as the pressure rises.

Selection of X-Sel® QUAD-RING® Seal for Rotary Applications

In applications with small cyclic periods of activity, X-Sel® QUAD-RING® Seal can be used for sealing rotating shafts. In this case, the following points should be observed:

To function as a rotary seal, X-Sel® QUAD-RING® Seal must be installed in accordance with the rotary seal principle. The rotary seal principle is based on the fact that an elongated elastomer ring (O-Ring or QUAD-RING® Seal) contracts when warm (Joule effect). With the normal method of installation (inside diameter $d_1 <$ shaft diameter), the frictional heat would cause the ring to contract even further. This results in a higher pressure on the rotating shaft so that a lubricant film is prevented from forming under the seal and even higher friction occurs. The result would be increased wear and premature failure of the seal.

Using the rotary seal principle, this is prevented by the seal ring being selected so that its inside diameter is approximately 2 to 5% larger than the shaft diameter to be sealed. The installation in the groove means that the seal ring is compressed radially and is pressed against the shaft by the groove root. The seal ring is thus slightly corrugated in the groove, which helps to improve the lubrication.

A special QUAD-RING® Seal, Type X-Sel®, is recommended for rotary seal applications. X-Sel® QUAD-RING® Seals have a special, thin and highly wear-resistant plastic coating. This blue coating reduces friction by absorbing lubricant in its porous surface and thus increasing the abrasion resistance.

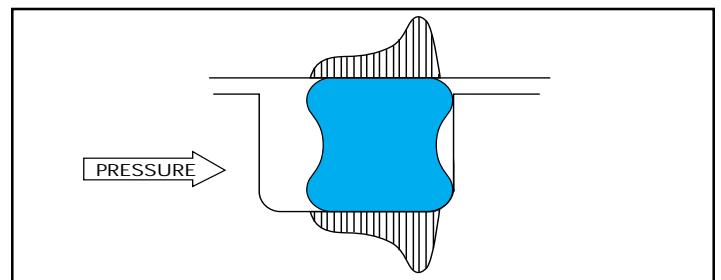

Figure 19 QUAD-RING® Seal load distribution profile



QUAD-RING® Seal Dimensional Data

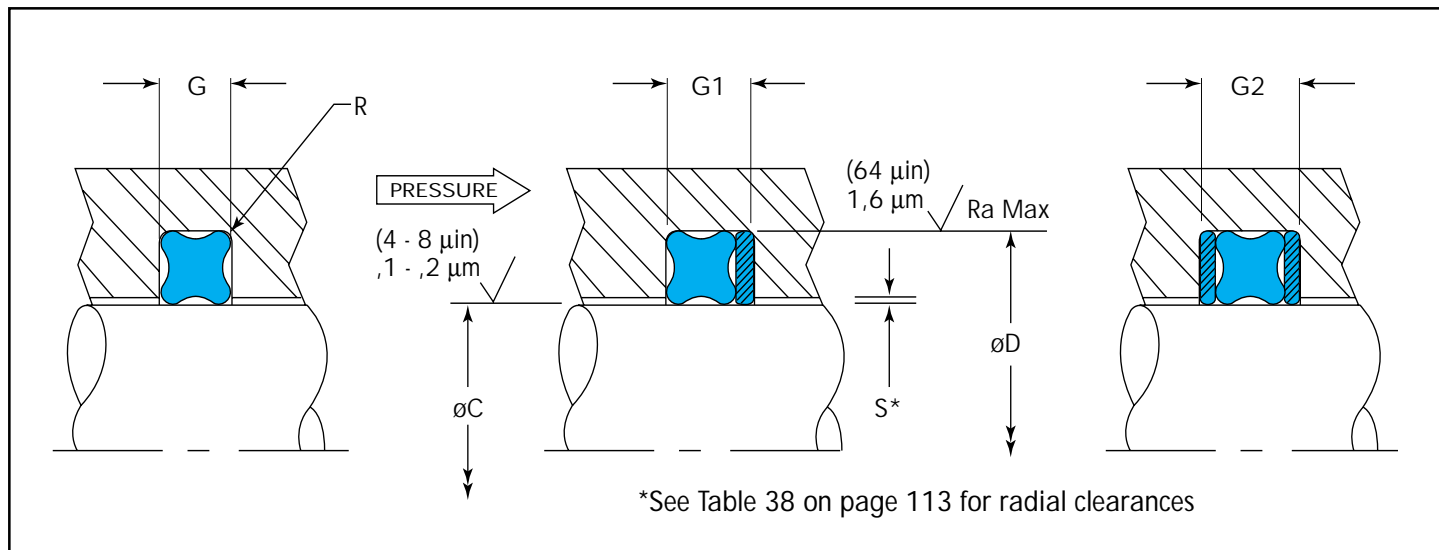

Table 24 QUAD-RING® Seal Ordering Information (Metric)

Rod C f8	Groove Diameter D H8	Groove Width (+ 0,2)			Radius R (Max)	QUAD-RING® Seal X-Sel® Part No.	Back-up Ring, Uncut Part No.
		G	G1	G2			
4,0	7,2	2,0	3,2	4,4	0,2	QBAR04008	BU16J0040
5,0	8,2	2,0	3,2	4,4	0,2	QBAR04009	BU16J0050
8,0	11,2	2,0	3,2	4,4	0,2	QBAR4012A	BU17J0080
10,0	14,8	2,8	4,0	5,2	0,3	QBAR4111A	BU24J0100
12,0	16,8	2,8	4,0	5,2	0,3	QBAR04112	BU24J0120
15,0	19,8	2,8	4,0	5,2	0,3	QBAR04114	BU24J0150
16,0	20,8	2,8	4,0	5,2	0,3	QBAR04115	BU24J0160
18,0	22,8	2,8	4,0	5,2	0,3	QBAR04116	BU24J0180
20,0	26,7	3,8	5,4	7,0	0,4	QBAR04211	BU33N0200
22,0	28,7	3,8	5,4	7,0	0,4	QBAR04213	BU33N0220
25,0	31,7	3,8	5,4	7,0	0,4	QBAR04215	BU33N0250
28,0	34,7	3,8	5,4	7,0	0,4	QBAR04217	BU33N0280
30,0	36,7	3,8	5,4	7,0	0,4	QBAR04218	BU33N0300
32,0	38,7	3,8	5,4	7,0	0,4	QBAR04219	BU33N0320
35,0	41,7	3,8	5,4	7,0	0,4	QBAR04221	BU33N0350
36,0	42,7	3,8	5,4	7,0	0,4	QBAR04222	BU33N0360
40,0	49,9	6,0	8,0	10,0	0,4	QBAR04326	BU49R0400
42,0	51,9	6,0	8,0	10,0	0,4	QBAR04327	BU49R0420
45,0	54,9	6,0	8,0	10,0	0,4	QBAR04328	BU49R0450
48,0	57,9	6,0	8,0	10,0	0,4	QBAR04329	BU49R0480



Table 24 QUAD-RING® Seal Ordering Information (Metric - Continued)

Rod C f8	Groove Diameter D H9	Groove Width (+ 0,2)			Radius R (Max)	QUAD-RING® Seal X-Sel® Part No.	Back-up Ring, Uncut Part No.
		G	G1	G2			
50,0	59,9	6,0	8,0	10,0	0,40	QBAR04330	BU49R0500
52,0	61,9	6,0	8,0	10,0	0,40	QBAR04330	BU49R0520
55,0	64,9	6,0	8,0	10,0	0,40	QBAR04331	BU49R0550
56,0	65,9	6,0	8,0	10,0	0,40	QBAR04331	BU49R0560
60,0	69,9	6,0	8,0	10,0	0,40	QBAR04333	BU49R0600
63,0	72,9	6,0	8,0	10,0	0,40	QBAR04334	BU49R0630
65,0	74,9	6,0	8,0	10,0	0,40	QBAR04334	BU49R0650
70,0	79,9	6,0	8,0	10,0	0,40	QBAR04336	BU49R0700
75,0	84,9	6,0	8,0	10,0	0,40	QBAR04338	BU49R0750
80,0	89,9	6,0	8,0	10,0	0,40	QBAR04339	BU49R0800
85,0	94,9	6,0	8,0	10,0	0,40	QBAR04341	BU49R0850
90,0	99,9	6,0	8,0	10,0	0,40	QBAR04343	BU49R0900
95,0	104,9	6,0	8,0	10,0	0,40	QBAR04344	BU49R0950
100,0	109,9	6,0	8,0	10,0	0,40	QBAR04346	BU49R1000
105,0	114,9	6,0	8,0	10,0	0,40	QBAR04348	BU49R1050
110,0	123,3	7,7	10,2	12,7	0,60	QBAR04426	BU66T1100
115,0	128,3	7,7	10,2	12,7	0,60	QBAR04427	BU66T1150
120,0	133,3	7,7	10,2	12,7	0,60	QBAR04428	BU66T1200
125,0	138,3	7,7	10,2	12,7	0,60	QBAR04430	BU66T1250
130,0	143,3	7,7	10,2	12,7	0,60	QBAR04432	BU66T1300
140,0	153,3	7,7	10,2	12,7	0,60	QBAR04435	BU66T1400
150,0	163,3	7,7	10,2	12,7	0,60	QBAR04438	BU66T1500
160,0	173,3	7,7	10,2	12,7	0,60	QBAR04439	BU66T1600
180,0	193,3	7,7	10,2	12,7	0,60	QBAR04442	BU66T1800
200,0	213,3	7,7	10,2	12,7	0,60	QBAR04445	BU66T2000



Table 25 QUAD-RING® Seal and Back-up Ring (uncut) for Rotary Applications Ordering Information (Internal Sealing) (Imperial)

Rod Diameter C f8	Groove Diameter D H9	Groove Width (+ 0,2)			Radius R (Max)	QUAD-RING® Seal X-Seal® Part No.	Back-up Ring, Uncut Part No.
		G	G1	G2			
.500	.691	.110	.158	.205	.010	QBAR04113	BU24J0127
.625	.816	.110	.158	.205	.010	QBAR04115	BU24J0159
.750	.941	.110	.158	.205	.010	QBAR04117	BU24J0191
.875	1.136	.150	.213	.276	.015	QBAR04213	BU33N0222
1.000	1.261	.150	.213	.276	.015	QBAR04215	BU33N0254
1.125	1.386	.150	.213	.276	.015	QBAR04217	BU33N0286
1.250	1.510	.150	.213	.276	.015	QBAR04219	BU33N0318
1.375	1.635	.150	.213	.276	.015	QBAR04221	BU33N0349
1.500	1.898	.235	.314	.393	.015	QBAR04326	BU50R0381
1.625	2.023	.235	.314	.393	.015	QBAR04327	BU50R0413
1.750	2.148	.235	.314	.393	.015	QBAR04328	BU50R0445
1.875	2.273	.235	.314	.393	.015	QBAR04329	BU50R0476
2.000	2.397	.235	.314	.393	.015	QBAR04330	BU50R0508
2.125	2.522	.235	.314	.393	.015	QBAR04331	BU50R0540
2.250	2.647	.235	.314	.393	.015	QBAR04332	BU50R0572
2.375	2.772	.235	.314	.393	.015	QBAR04333	BU50R0603
2.500	2.897	.235	.314	.393	.015	QBAR04334	BU50R0635
2.625	3.022	.235	.314	.393	.015	QBAR04335	BU50R0668
2.750	3.147	.235	.314	.393	.015	QBAR04336	BU50R0699
2.875	3.272	.235	.314	.393	.015	QBAR04337	BU50R0730
3.000	3.397	.235	.314	.393	.015	QBAR04338	BU50R0762
3.125	3.522	.235	.314	.393	.015	QBAR04339	BU50R0794
3.250	3.646	.235	.314	.393	.015	QBAR04340	BU50R0826
3.375	3.771	.235	.314	.393	.015	QBAR04341	BU50R0857
3.500	3.896	.235	.314	.393	.015	QBAR04342	BU50R0889
3.625	4.021	.235	.314	.393	.015	QBAR04343	BU50R0921
3.750	4.146	.235	.314	.393	.015	QBAR04344	BU50R0953
3.875	4.271	.235	.314	.393	.015	QBAR04345	BU50R0984
4.000	4.396	.235	.314	.393	.015	QBAR04346	BU50R1016
4.125	4.521	.235	.314	.393	.015	QBAR04347	BU50R1048
4.250	4.646	.235	.314	.393	.015	QBAR04348	BU50R1080
4.375	4.771	.235	.314	.393	.015	QBAR04349	BU50R1111
4.500	4.896	.235	.314	.393	.015	QBAR04350	BU50R1143
4.625	5.145	.305	.404	.502	.025	QBAR04427	BU66T1175
4.750	5.269	.305	.404	.502	.025	QBAR04428	BU66T1207



Table 25 QUAD-RING® Seal and Back-up Ring (uncut) for Rotary Applications Ordering Information (Internal Sealing) (Imperial- Continued)

Rod Diameter C f8	Groove Diameter D (H8)	Groove Width (+ .005)			Radius R(Max)	QUAD-RING® Seal X-Seal® Part No.	Back-up Ring Uncut Part No.
		G1	G2	G3			
4.875	5.394	.305	.404	.502	.025	QBAR04429	BU66T1238
5.000	5.519	.305	.404	.502	.025	QBAR04430	BU66T1270
5.125	5.644	.305	.404	.502	.025	QBAR04431	BU66T1302
5.250	5.769	.305	.404	.502	.025	QBAR04432	BU66T1334
5.375	5.894	.305	.404	.502	.025	QBAR04433	BU66T1365
5.500	6.019	.305	.404	.502	.025	QBAR04434	BU66T1397
5.625	6.144	.305	.404	.502	.025	QBAR04435	BU66T1429
5.750	6.269	.305	.404	.502	.025	QBAR04436	BU66T1461
5.875	6.394	.305	.404	.502	.025	QBAR04437	BU66T1492
6.000	6.519	.305	.404	.502	.025	QBAR04438	BU66T1524
6.250	6.769	.305	.404	.502	.025	QBAR04439	BU66T1588
6.500	7.019	.305	.404	.502	.025	QBAR04440	BU66T1651
6.750	7.269	.305	.404	.502	.025	QBAR04441	BU66T1715
7.000	7.519	.305	.404	.502	.025	QBAR04442	BU66T1778
7.250	7.768	.305	.404	.502	.025	QBAR04443	BU66T1842
7.500	8.018	.305	.404	.502	.025	QBAR04444	BU66T1905
7.750	8.268	.305	.404	.502	.025	QBAR04445	BU66T1969
8.000	8.518	.305	.404	.502	.025	QBAR04446	BU66T2032
8.500	9.018	.305	.404	.502	.025	QBAR04447	BU66T2159
9.000	9.518	.305	.404	.502	.025	QBAR04448	BU66T2286
9.500	10.018	.305	.404	.502	.025	QBAR04449	BU66T2413
10.000	10.517	.305	.404	.502	.025	QBAR04450	BU66T2540
10.500	11.017	.305	.404	.502	.025	QBAR04451	BU66T2667
11.000	11.517	.305	.404	.502	.025	QBAR04452	BU66T2794
11.500	12.017	.305	.404	.502	.025	QBAR04453	BU66T2921
12.000	12.517	.305	.404	.502	.025	QBAR04454	BU66T3048
12.500	13.017	.305	.404	.502	.025	QBAR04455	BU66T3175
13.000	13.517	.305	.404	.502	.025	QBAR04456	BU66T3302
13.500	14.017	.305	.404	.502	.025	QBAR04457	BU66T3429
14.000	14.517	.305	.404	.502	.025	QBAR04458	BU66T3556
14.500	15.017	.305	.404	.502	.025	QBAR04459	BU66T3683
15.000	15.517	.305	.404	.502	.025	QBAR04460	BU66T3810
15.500	16.017	.305	.404	.502	.025	QBAR04461	BU66T3937
16.000	16.516	.305	.404	.502	.025	QBAR04462	BU66T4064
16.500	17.016	.305	.404	.502	.025	QBAR04463	BU66T4191



Table 25 QUAD-RING® Seal and Back-up Ring (uncut) for Rotary Applications Ordering Information (Internal Sealing) (Imperial- Continued)

Rod Diameter C f8	Groove Diameter D (H8)	Groove Width (+ .005)			Radius R(Max)	QUAD-RING® Seal X-Sel® Part No.	Back-up Ring Uncut Part No.
		G1	G2	G3			
17.000	17.516	.305	.404	.502	.025		
17.500	18.016	.305	.404	.502	.025		
18.000	18.516	.305	.404	.502	.025		
18.500	19.016	.305	.404	.502	.025		
19.000	19.516	.305	.404	.502	.025		
19.500	20.016	.305	.404	.502	.025		
20.000	20.514	.305	.404	.502	.025		

Ordering Example

X-sel® QUAD-RING® Seal and Back-up Ring for rod diameter C = 50,0 mm

QUAD-RING® Seal according to AS 568A

Dimensions: Inside diameter $d_1 = 53,34$ mm
Cord diameter $W = 5,33$ mm

Compound: NBR 70 (Acrylonitrile Butadiene Elastomer, 70 Shore A)

Order No., QUAD-RING® Seal dimensions and installation dimensions see Tables 24 and 25 on pages 75 through 79. Standard compound NBR with X-sel coating. The X-sel coating is indicated by letter B in the second position of Order No.

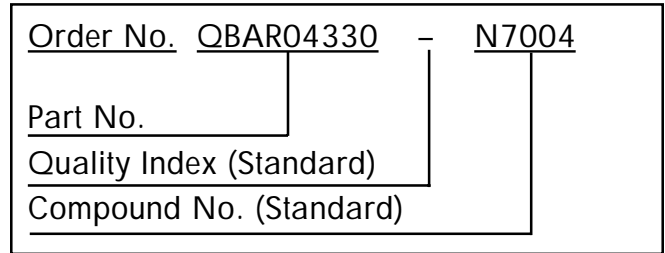

Back-up Ring, type BU (uncut) fitted for QUAD-RING® Seal rod diameter C = 50,0 mm and cord diameter $W = 5,33$ mm

Compound: PTFE (Polytetrafluorethylene)

Order No., and installation dimensions see Tables 24 and 25 on pages 75 through 79. Standard compound PTFE

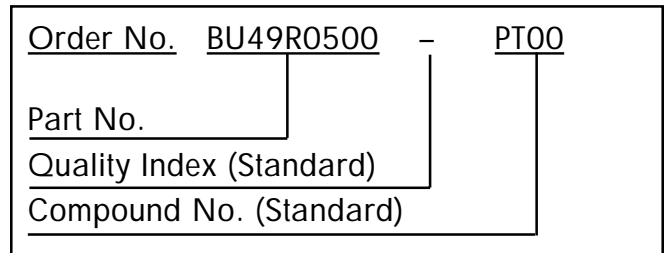

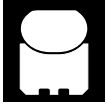

■ General

Description

The Turcon® Roto Glyd Ring® is used to seal rods, axles, rotary leadthroughs, journals, etc. with rotary or oscillating movement.

The seal is double-acting and can be exposed to pressure on both or on alternating sides.

It consists of a seal ring of high grade Turcon® materials and is activated by an O-Ring as an elastic energizing element.

The contact surface profile of the seal ring is designed for use under pressure and at low sliding speeds.

Depending on the profile cross section of the seal, the contact surface has one or two continuous machined grooves which serve to:

- Improve seal efficiency by increasing the specified surface load pressure against the sealed surface.
- Form a lubricant reservoir and reduce friction.

In order to improve the pressure activation of the O-Ring, the Turcon® Roto Glyd Ring® has notched end faces as standard.

The rear face which holds the O-Ring has a concave form. This increases the contact surface and prevents the seal from turning with the shaft.

Advantages

- Available for internal and external sealing applications
- Low friction
- Stick-slip-free starting, no sticking
- High abrasion resistance and dimensional stability
- Simple groove design, small groove dimensions
- Lubricant reservoir
- Available in all sizes up to 2.500 mm (100 inches) diameter

Technical Data

Operating Pressure:	up to 30 MPa (4350 psi)
Speed:	up 2 m/s (6,6 ft/s)
Temperature:	-54°C to +200°C (-65°F to +392°F) (depending on O-Ring material)
Media:	Mineral oil based hydraulic fluids, flame retardant hydraulic fluids, environmentally safe hydraulic fluids (bio-oils), water, air, and others, depending on O-Ring material.
Note:	For continuous operation at temperatures over +60°C (140°F), pressure and speed must be limited.

Materials

Standard materials:

Turcon® seal ring: Turcon® T40

O-Ring: NBR, 70 Shore A, Material No. N7038

For specific applications, other material combinations as listed in Table 1, page 2 may also be used.

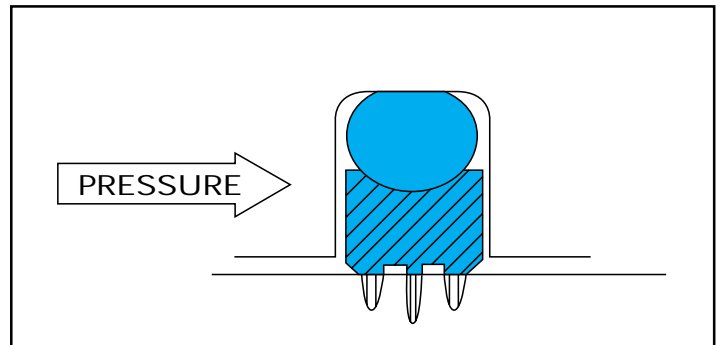

Figure 20 Load distribution profile



Installation Recommendations/External Sealing

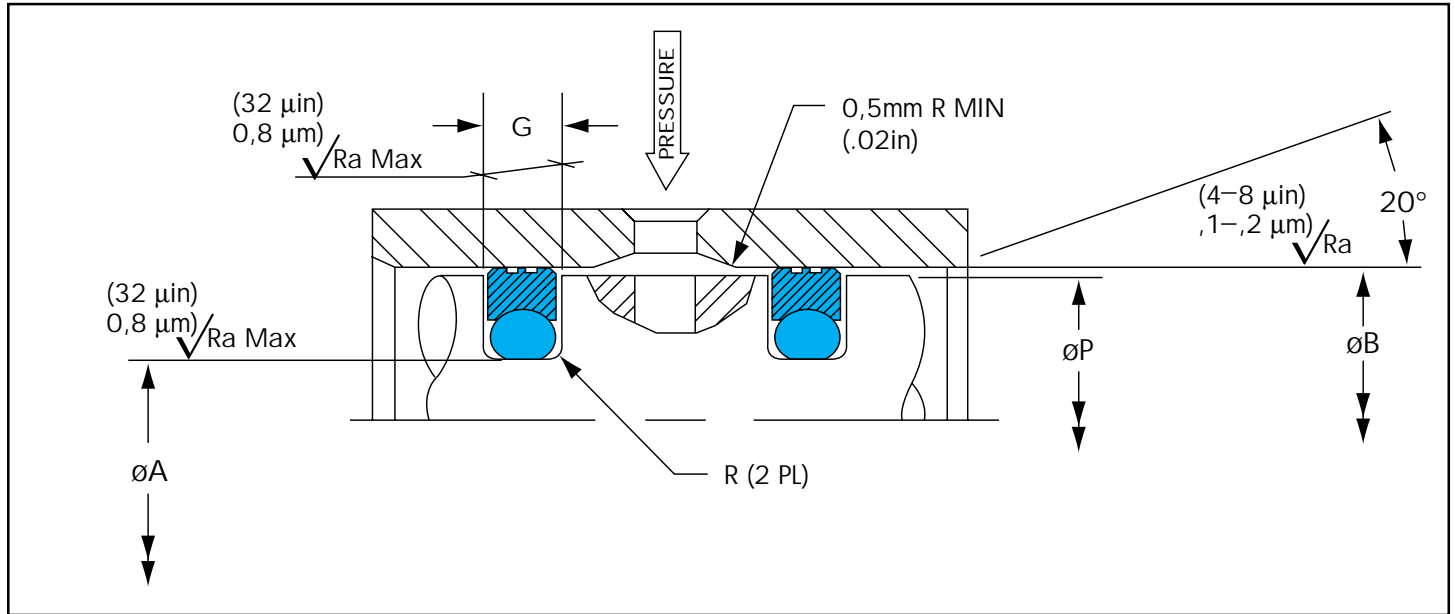

Table 26 Ordering Information/External Sealing (Metric)

Bore Diameter B H9	Groove Diameter A H9	Groove Width G+0,2	Minimum Piston Diameter P		Radius R (Max)	O-Ring Dash No.	Turcon® Roto Glyd Ring® Part Number
			10 MPa	20 MPa			
16,0	11,1	2,2	15,74	15,84	0,40	013	TG4000160
18,0	13,1	2,2	17,75	17,85	0,40	014	TG4000180
20,0	15,1	2,2	19,75	19,85	0,40	015	TG4000200
22,0	17,1	2,2	21,75	21,85	0,40	017	TG4000220
25,0	20,1	2,2	24,75	24,85	0,40	018	TG4000250
28,0	23,1	2,2	27,75	27,85	0,40	020	TG4000280
30,0	25,1	2,2	29,76	29,86	0,40	022	TG4000300
32,0	27,1	2,2	31,76	31,86	0,40	023	TG4000320
35,0	30,1	2,2	34,76	34,86	0,40	025	TG4000350
40,0	32,5	3,2	39,66	39,76	0,60	124	TG4100400
42,0	34,5	3,2	41,66	41,76	0,60	125	TG4100420
45,0	37,5	3,2	44,66	44,76	0,60	127	TG4100450
48,0	40,5	3,2	47,66	47,76	0,60	129	TG4100480
50,0	42,5	3,2	49,67	49,77	0,60	130	TG4100500
52,0	44,5	3,2	51,67	51,77	0,60	132	TG4100520

The bore diameters printed in **bold** type conform to the recommendations of ISO 3320.



Table 26 Ordering Information/External Sealing (Metric - Continued)

Bore Diameter B H9	Groove Diameter A H9	Groove Width G+0,2	Minimum Piston Diameter P		Radius R (Max)	O-Ring Dash No.	Turcon® Roto Glyd Ring® Part Number
			10 MPa	20 MPa			
55,0	47,5	3,2	54,67	54,77	0,60	133	TG4100550
60,0	52,5	3,2	59,67	59,77	0,60	137	TG4100600
63,0	55,5	3,2	62,67	62,77	0,60	138	TG4100630
65,0	57,5	3,2	64,67	64,77	0,60	140	TG4100650
70,0	62,5	3,2	69,67	69,77	0,60	143	TG4100700
75,0	67,5	3,2	74,67	74,77	0,60	146	TG4100750
80,0	69,0	4,2	79,59	79,69	1,00	231	TG4200800
85,0	74,0	4,2	84,59	84,69	1,00	233	TG4200850
90,0	79,0	4,2	89,59	89,69	1,00	234	TG4200900
95,0	84,0	4,2	94,59	94,69	1,00	236	TG4200950
100,0	89,0	4,2	99,59	99,69	1,00	237	TG4201000
105,0	94,0	4,2	104,59	104,69	1,00	239	TG4201050
110,0	99,0	4,2	109,59	109,69	1,00	241	TG4201100
115,0	104,0	4,2	114,59	114,69	1,00	243	TG4201150
120,0	109,0	4,2	119,60	119,70	1,00	244	TG4201200
125,0	114,0	4,2	124,60	124,70	1,00	245	TG4201250
130,0	119,0	4,2	129,60	129,70	1,00	247	TG4201300
135,0	119,5	6,3	134,50	134,60	1,30	350	TG4301350
140,0	124,5	6,3	139,50	139,60	1,30	352	TG4301400
150,0	134,5	6,3	149,50	149,60	1,30	355	TG4301500
160,0	144,5	6,3	159,50	159,60	1,30	358	TG4301600
170,0	154,5	6,3	169,50	169,60	1,30	361	TG4301700
180,0	164,5	6,3	179,52	179,62	1,30	363	TG4301800
190,0	174,5	6,3	189,52	189,62	1,30	364	TG4301900
200,0	184,5	6,3	199,52	199,62	1,30	366	TG4302000
210,0	194,5	6,3	209,52	209,62	1,30	367	TG4302100
220,0	204,5	6,3	219,52	219,62	1,30	369	TG4302200
230,0	214,5	6,3	229,52	229,62	1,30	370	TG4302300
240,0	224,5	6,3	239,52	239,62	1,30	372	TG4302400
250,0	234,5	6,3	249,53	249,63	1,30	374	TG4302500
280,0	264,5	6,3	279,53	279,63	1,30	377	TG4302800
300,0	284,5	6,3	299,53	299,63	1,30	379	TG4303000
320,0	304,5	6,3	319,54	319,64	1,30	381	TG4303200
350,0	329,0	8,1	349,54	349,64	1,80	454	TG4403500
360,0	339,0	8,1	359,54	359,96	1,80	455	TG4403600

The bore diameters printed in **bold** type conform to the recommendations of ISO 3320.



Table 26 Ordering Information/External Sealing (Metric - Continued)

Bore Diameter B H9	Groove Diameter A H9	Groove Width G+0,2	Minimum Piston Diameter P		Radius R (Max)	O-Ring Dash No.	Turcon® Roto Glyd Ring® Part Number
			10 MPa	20 MPa			
400,0	379,0	8,1	399,56	399,66	1,80	458	TG4404000
420,0	399,0	8,1	419,56	419,66	1,80	460	TG4404200
450,0	429,0	8,1	449,56	449,66	1,80	462	TG4404500
480,0	459,0	8,1	479,56	479,66	1,80	465	TG4404800
500,0	479,0	8,1	499,57	499,67	1,80	466	TG4405000
600,0	579,0	8,1	599,57	599,67	1,80	471	TG4406000

The bore diameters printed in **bold** type conform to the recommendations of ISO 3320.

Other dimensions and all intermediate sizes up to 2500 mm diameter including imperial (inch) sizes can be supplied.

* Matching O-Rings may have either larger or smaller ID than the groove diameter. However, the differences shall not affect the performance and reliability of the seal once the Roto Glyd Ring® is installed properly.

Table 27 Ordering Information/External Sealing (Imperial)

Bore Diameter B H9	Groove Diameter A h9	Groove Width G+.008	Minimum Piston Diameter P		Radius R (Max)	O-Ring Dash No.	Turcon® Roto Glyd Ring® Part Number
			1000 psi	3000 psi			
0.375	0.182	.087	0.356	0.362	0.015	008	TGP000375
0.438	0.245	.087	0.420	0.426	0.015	010	TGP000438
0.500	0.307	.087	0.483	0.489	0.015	011	TGP000500
0.563	0.370	.087	0.545	0.556	0.015	012	TGP000563
0.625	0.432	.087	0.607	0.613	0.015	013	TGP000625
0.688	0.495	.087	0.670	0.676	0.015	014	TGP000688
0.750	0.557	.087	0.732	0.738	0.015	015	TGP000750
0.813	0.620	.087	0.795	0.801	0.015	016	TGP000813
0.875	0.682	.087	0.857	0.863	0.015	017	TGP000875
0.938	0.745	.087	0.920	0.926	0.015	018	TGP000938
1.000	0.807	.087	0.982	0.988	0.015	019	TGP001000
1.125	0.932	.087	1.107	1.113	0.015	021	TGP001125
1.250	1.057	.087	1.232	1.238	0.015	023	TGP001250
1.375	1.182	.087	1.357	1.363	0.015	025	TGP001375
1.500	1.205	.126	1.472	1.482	0.015	123	TGP101500
1.625	1.330	.126	1.597	1.607	0.015	125	TGP101625
1.750	1.455	.126	1.722	1.732	0.015	127	TGP101750
1.875	1.580	.126	1.847	1.857	0.015	129	TGP101875

Bold print indicates Busak+Shamban Preferred Design sizes.



Table 27 Ordering Information/External Sealing (Imperial - continued)

Bore Diameter B H9	Groove Diameter A h9	Groove Width G+.008	Minimum Piston Diameter P		Radius R (Max)	O-Ring Dash No.	Turcon® Roto Glyd Ring® Part Number
			1000 psi	3000 psi			
2.000	1.705	.126	1.973	1.983	0.015	131	TGP102000
2.125	1.830	.126	2.098	2.108	0.015	133	TGP102125
2.250	1.955	.126	2.223	2.233	0.015	135	TGP102250
2.375	2.080	.126	2.348	2.358	0.015	137	TGP102375
2.500	2.205	.126	2.473	2.483	0.015	139	TGP102500
2.625	2.330	.126	2.598	2.608	0.015	141	TGP102625
2.750	2.455	.126	2.723	2.733	0.015	143	TGP102750
2.875	2.580	.126	2.848	2.858	0.015	145	TGP102875
3.000	2.567	.165	2.963	2.973	0.015	230	TGP203000
3.125	2.692	.165	3.088	3.098	0.015	231	TGP203125
3.250	2.817	.165	3.213	3.223	0.015	232	TGP203250
3.375	2.942	.165	3.338	3.348	0.015	233	TGP203375
3.500	3.067	.165	3.463	3.473	0.015	234	TGP203500
3.625	3.192	.165	3.588	3.598	0.015	235	TGP203625
3.750	3.317	.165	3.713	3.723	0.015	236	TGP203750
3.875	3.492	.165	3.838	3.848	0.015	237	TGP203875
4.000	3.567	.165	3.963	3.973	0.015	238	TGP204000
4.125	3.692	.165	4.088	4.098	0.015	239	TGP204125
4.250	3.817	.165	4.213	4.223	0.015	240	TGP204250
4.375	3.942	.165	4.338	4.348	0.015	241	TGP204375
4.500	4.067	.165	4.463	4.473	0.015	242	TGP204500
4.625	4.192	.165	4.588	4.598	0.015	243	TGP204625
4.750	4.317	.165	4.714	4.724	0.015	244	TGP204750
4.875	4.442	.165	4.839	4.849	0.015	245	TGP204875
5.000	4.567	.165	4.964	4.974	0.015	246	TGP205000
5.125	4.692	.165	5.089	5.099	0.015	247	TGP205125
5.250	4.817	.165	5.214	5.224	0.015	248	TGP205250
5.375	4.942	.165	5.339	5.349	0.015	249	TGP205375
5.500	5.067	.165	5.464	5.474	0.015	250	TGP205500
5.625	5.192	.165	5.589	5.599	0.015	251	TGP205625
5.750	5.317	.165	5.714	5.724	0.015	252	TGP205750
5.875	5.442	.165	5.839	5.849	0.015	253	TGP205875
6.000	5.390	.248	5.959	5.969	0.035	355	TGP306000
6.250	5.640	.248	6.209	6.219	0.035	357	TGP306250
6.500	5.890	.248	6.459	6.469	0.035	359	TGP306500

Bold print indicates Busak+Shamban Preferred Design sizes.



Table 27 Ordering Information/External Sealing (Imperial - continued)

Bore Diameter B H9	Groove Diameter A h9	Groove Width G+.008	Minimum Piston Diameter P		Radius R (Max)	O-Ring Dash No.	Turcon® Roto Glyd Ring® Part Number
			1000 psi	3000 psi			
6.750	6.140	.248	6.709	6.719	0.035	361	TGP306750
7.000	6.390	.248	6.959	6.969	0.035	362	TGP307000
7.250	6.640	.248	7.210	7.220	0.035	363	TGP307250
7.500	6.890	.248	7.460	7.470	0.035	364	TGP307500
8.250	7.640	.248	8.210	8.220	0.035	367	TGP308250
8.500	7.890	.248	8.460	8.470	0.035	368	TGP308500
8.750	8.140	.248	8.710	8.720	0.035	369	TGP308750
9.000	8.390	.248	8.960	8.970	0.035	370	TGP309000
9.250	8.640	.248	9.210	9.220	0.035	371	TGP309250
9.500	8.890	.248	9.460	9.470	0.035	372	TGP309500
9.750	9.140	.248	9.710	9.720	0.035	373	TGP309750
10.000	9.390	.248	9.960	9.970	0.035	374	TGP310000
10.500	9.890	.248	10.460	10.470	0.035	376	TGP310500
11.000	10.390	.248	10.960	10.970	0.035	377	TGP311000
11.500	10.890	.248	11.460	11.470	0.035	378	TGP311500
12.000	11.173	.319	11.955	11.965	0.035	451	TGP412000
12.500	11.673	.319	12.456	12.466	0.035	452	TGP412500
13.000	12.173	.319	12.956	12.966	0.035	453	TGP413000
13.500	12.673	.319	13.456	13.466	0.035	454	TGP413500
14.000	13.173	.319	13.956	13.966	0.035	455	TGP414000
14.500	13.673	.319	14.456	14.466	0.035	456	TGP414500
15.000	14.173	.319	14.956	14.966	0.035	457	TGP415000
15.500	14.673	.319	15.456	15.466	0.035	458	TGP415500
16.000	15.173	.319	15.956	15.966	0.035	459	TGP416000
16.500	15.673	.319	16.456	16.466	0.035	460	TGP416500
17.000	16.173	.319	16.956	16.966	0.035	461	TGP417000
17.500	16.673	.319	17.456	17.466	0.035	462	TGP417500
18.000	17.173	.319	17.956	17.966	0.035	463	TGP418000
18.500	17.673	.319	18.456	18.466	0.035	464	TGP418500
19.000	18.173	.319	18.956	18.966	0.035	465	TGP419000
19.500	18.673	.319	19.456	19.466	0.035	466	TGP419500
20.000	19.173	.319	19.957	19.967	0.035	467	TGP420000

Bold print indicates Busak+Shamban Preferred Design sizes.

Matching O-Rings may have either larger or smaller ID than the groove diameter. However, the differences shall not affect the performance and reliability of the seal once the Roto Glyd Ring® is installed properly. Different O-Rings may also be used (see O-Ring section on choosing O-Rings).



Installation Recommendations/Internal Sealing

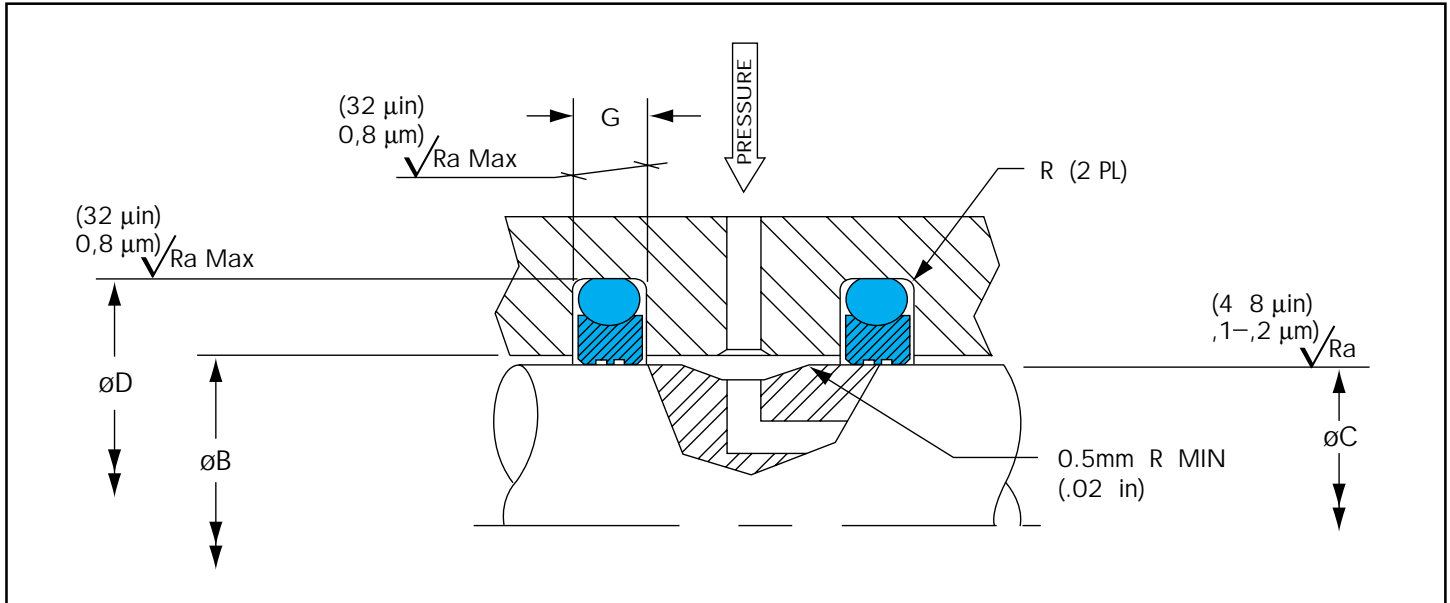

Table 28 Ordering Information/Internal Sealing (Metric)

Shaft Diameter C f8	Groove Diameter D H9	Groove Width G+0,2	Maximum Bore Diameter B		Radius R (Max)	O-Ring Dash No.	Turcon® Roto Glyd Ring® Part Number
			100 Bar	200 Bar			
12,0	16,9	2,2	12,26	12,16	0,4	015	TG3000120
14,0	18,9	2,2	14,26	14,16	0,4	016	TG3000140
15,0	19,9	2,2	15,26	15,16	0,4	017	TG3000150
16,0	20,9	2,2	16,26	16,16	0,4	017	TG3000160
18,0	22,9	2,2	18,25	18,15	0,4	018	TG3000180
20,0	27,5	3,2	20,35	20,25	0,6	118	TG3100200
22,0	29,5	3,2	22,35	22,25	0,6	120	TG3100220
25,0	32,5	3,2	25,35	25,25	0,6	122	TG3100250
28,0	35,5	3,2	28,35	28,25	0,6	124	TG3100280
30,0	37,5	3,2	30,34	30,24	0,6	125	TG3100300
32,0	39,5	3,2	32,34	32,24	0,6	126	TG3100320
35,0	42,5	3,2	35,34	35,24	0,6	128	TG3100350
36,0	43,5	3,2	36,34	36,24	0,6	129	TG3100360
40,0	51,0	4,2	40,44	40,34	1,0	224	TG3200400
42,0	53,0	4,2	42,44	42,34	1,0	225	TG3200420

Sizes in **bold** type comply with ISO 3320.



Table 28 Ordering Information/Internal Sealing (Metric - Continued)

Shaft Diameter C f8	Groove Diameter D H9	Groove Width G+0,2	Maximum Bore Diameter B		Radius R (Max)	O-Ring Dash No.	Turcon® Roto Glyd Ring® Part Number
			100 Bar	200 Bar			
45,0	56,0	4,2	45,44	45,34	1,0	226	TG3200450
48,0	59,0	4,2	48,44	48,34	1,0	227	TG3200480
50,0	61,0	4,2	50,42	50,32	1,0	227	TG3200500
52,0	63,0	4,2	52,42	52,32	1,0	228	TG3200520
55,0	66,0	4,2	55,42	55,32	1,0	229	TG3200550
56,0	67,0	4,2	56,42	56,32	1,0	229	TG3200560
60,0	71,0	4,2	60,42	60,32	1,0	230	TG3200600
63,0	74,0	4,2	63,42	63,32	1,0	231	TG3200630
65,0	76,0	4,2	65,42	65,32	1,0	232	TG3200650
70,0	81,0	4,2	70,42	70,32	1,0	234	TG3200700
75,0	86,0	4,2	75,42	75,32	1,0	235	TG3200750
80,0	91,0	4,2	80,41	80,31	1,0	237	TG3200800
85,0	96,0	4,2	85,41	85,31	1,0	238	TG3200850
90,0	101,0	4,2	90,41	90,31	1,0	240	TG3200900
95,0	106,0	4,2	95,41	95,31	1,0	241	TG3200950
100,0	111,0	4,2	100,41	100,31	1,0	243	TG3201000
105,0	116,0	4,2	105,41	105,31	1,0	245	TG3201050
110,0	121,0	4,2	110,41	110,31	1,0	246	TG3201100
115,0	126,0	4,2	115,41	115,31	1,0	248	TG3201150
120,0	131,0	4,2	120,39	120,29	1,0	249	TG3201200
125,0	136,0	4,2	125,39	125,29	1,0	251	TG3201250
130,0	141,0	4,2	130,39	130,29	1,0	252	TG3201300
135,0	146,0	4,2	135,39	135,29	1,0	254	TG3201350
140,0	151,0	4,2	140,39	140,29	1,0	256	TG3201400
150,0	161,0	4,2	150,39	150,29	1,0	258	TG3201500
160,0	171,0	4,2	160,39	160,29	1,0	260	TG3201600
170,0	181,0	4,2	170,39	170,29	1,0	262	TG3201700
180,0	191,0	4,2	180,38	180,29	1,0	263	TG3201800
190,0	201,0	4,2	190,38	190,28	1,0	265	TG3201900
200,0	215,5	6,3	200,48	200,38	1,3	369	TG3302000
210,0	225,5	6,3	210,48	210,38	1,3	371	TG3302100
220,0	235,5	6,3	220,48	220,38	1,3	373	TG3302200
230,0	245,5	6,3	230,48	230,38	1,3	374	TG3302300
240,0	255,5	6,3	240,48	240,38	1,3	376	TG3302400

Sizes in **bold** type comply with ISO 3320.



Table 28 Ordering Information/Internal Sealing (Metric - Continued)

Shaft Diameter C f8	Groove Diameter D H9	Groove Width G+0,2	Maximum Bore Diameter B		Radius R (Max)	O-Ring Dash No.	Turcon® Roto Glyd Ring® Part Number
			100 Bar	200 Bar			
250 ,0	265,5	6,3	250 ,46	250 ,36	1,3	377	TG3302500
280 ,0	301,0	8,1	280 ,46	280 ,36	1,8	452	TG3402800
300 ,0	321,0	8,1	300 ,46	300 ,36	1,8	453	TG3403000
320 ,0	341,0	8,1	320 ,45	320 ,35	1,8	455	TG3403200
350 ,0	371,0	8,1	350 ,45	350 ,35	1,8	457	TG3403500
360 ,0	381,0	8,1	360 ,45	360 ,35	1,8	458	TG3403600
400 ,0	421,0	8,1	400 ,45	400 ,35	1,8	461	TG3404000
420 ,0	441,0	8,1	420 ,44	420 ,34	1,8	463	TG3404200
450 ,0	471,0	8,1	450 ,44	450 ,34	1,8	465	TG3404500
480 ,0	501,0	8,1	480 ,44	480 ,34	1,8	467	TG3404800

Sizes in **bold** type comply with ISO 3320.

Other dimensions and all intermediate sizes up to 2500 mm diameter can be supplied.

Matching O-Rings may have either larger or smaller ID than the groove diameter. However, the differences shall not affect the performance and reliability of the seal once the Roto Glyd Ring® is installed properly.



Table 29 Ordering Information/Internal Sealing (Imperial)

Shaft Diameter C f8	Groove Diameter D H9	Groove Width G+.008	Maximum Bore Diameter B		Radius R (Max)	O-Ring Dash No.	Turcon® Roto Glyd Ring® Part Number
			1000 psi	3000 psi			
1.000	1.193	0.087	1.018	1.012	0.015	023	TGR001000
1.125	1.318	0.087	1.143	1.137	0.015	025	TGR001125
1.250	1.443	0.087	1.267	1.261	0.015	027	TGR001250
1.375	1.568	0.087	1.392	1.386	0.015	028	TGR001375
1.500	1.795	0.126	1.527	1.517	0.015	130	TGR101500
1.625	1.920	0.126	1.652	1.642	0.015	132	TGR101625
1.750	2.045	0.126	1.777	1.767	0.015	134	TGR101750
1.875	2.170	0.126	1.902	1.892	0.015	135	TGR101875
2.000	2.295	0.126	2.027	2.017	0.015	137	TGR102000
2.125	2.420	0.126	2.152	2.142	0.015	139	TGR102125
2.250	2.545	0.126	2.277	2.267	0.015	141	TGR102250
2.375	2.670	0.126	2.402	2.392	0.015	143	TGR102375
2.500	2.795	0.126	2.527	2.517	0.015	145	TGR102500
2.625	2.920	0.126	2.652	2.642	0.015	147	TGR102625
2.750	3.045	0.126	2.777	2.767	0.015	149	TGR102750
2.875	3.170	0.126	2.902	2.892	0.015	150	TGR102875
3.000	3.433	0.165	3.037	3.027	0.015	235	TGR203000
3.125	3.558	0.165	3.162	3.152	0.015	236	TGR203125
3.250	3.683	0.165	3.286	3.276	0.015	237	TGR203250
3.375	3.808	0.165	3.411	3.401	0.015	238	TGR203375
3.500	3.933	0.165	3.536	3.526	0.015	239	TGR203500
3.625	4.058	0.165	3.661	3.651	0.015	240	TGR203625
3.750	4.183	0.165	3.786	3.776	0.015	241	TGR203750
3.875	4.308	0.165	3.911	3.901	0.015	242	TGR203875
4.000	4.433	0.165	4.036	4.026	0.015	243	TGR204000
4.125	4.558	0.165	4.161	4.151	0.015	244	TGR204125
4.250	4.683	0.165	4.286	4.276	0.015	245	TGR204250
4.375	4.808	0.165	4.411	4.401	0.015	246	TGR204375
4.500	4.933	0.165	4.536	4.526	0.015	247	TGR204500
4.625	5.058	0.165	4.661	4.651	0.015	248	TGR204625
4.750	5.183	0.165	4.786	4.776	0.015	249	TGR204750
4.875	5.308	0.165	4.911	4.901	0.015	250	TGR204875
5.000	5.433	0.165	5.036	5.026	0.015	251	TGR205000
5.125	5.558	0.165	5.161	5.151	0.015	252	TGR205125
5.250	5.683	0.165	5.286	5.276	0.015	253	TGR205250

Bold print indicates Busak+Shamban Preferred Design sizes.



Table 29 Ordering Information/Internal Sealing (Imperial - Continued)

Shaft Diameter C f8	Groove Diameter D H9	Groove Width G+.008	Maximum Bore Diameter B		Radius R (Max)	O-Ring Dash No.	Turcon® Roto Glyd Ring® Part Number
			1000 psi	3000 psi			
5.375	5.808	0.165	5.411	5.401	0.015	254	TGR205375
5.500	5.933	0.165	5.536	5.526	0.015	255	TGR205500
5.625	6.058	0.165	5.661	5.651	0.015	256	TGR205625
5.750	6.183	0.165	5.786	5.776	0.015	257	TGR205750
5.875	6.308	0.165	5.911	5.901	0.015	258	TGR205875
6.000	6.610	0.248	6.041	6.031	0.035	362	TGR306000
6.250	6.860	0.248	6.291	6.281	0.035	363	TGR306250
6.500	7.110	0.248	6.541	6.531	0.035	364	TGR306500
6.750	7.360	0.248	6.791	6.781	0.035	365	TGR306750
7.000	7.610	0.248	7.041	7.031	0.035	365	TGR307000
7.250	7.860	0.248	7.290	7.280	0.035	366	TGR307250
7.500	8.110	0.248	7.540	7.530	0.035	367	TGR307500
7.750	8.360	0.248	7.790	7.780	0.035	368	TGR307750
8.000	8.610	0.248	8.040	8.030	0.035	369	TGR308000
8.250	8.860	0.248	8.290	8.280	0.035	370	TGR308250
8.500	9.110	0.248	8.540	8.530	0.035	371	TGR308500
8.750	9.360	0.248	8.790	8.780	0.035	372	TGR308750
9.000	9.610	0.248	9.040	9.030	0.035	373	TGR309000
9.250	9.860	0.248	9.290	9.280	0.035	374	TGR309250
9.500	10.110	0.248	9.540	9.530	0.035	375	TGR309500
9.750	10.360	0.248	9.790	9.780	0.035	376	TGR309750
10.000	10.610	0.248	10.040	10.030	0.035	377	TGR310000
10.500	11.110	0.248	10.540	10.530	0.035	378	TGR310500
11.000	11.610	0.248	11.040	11.030	0.035	379	TGR311000
11.500	12.110	0.248	11.540	11.530	0.035	380	TGR311500
12.000	12.827	0.319	12.045	12.035	0.035	453	TGR412000
12.500	13.327	0.319	12.544	12.534	0.035	454	TGR412500
13.000	13.827	0.319	13.044	13.034	0.035	455	TGR413000
13.500	14.327	0.319	13.544	13.534	0.035	456	TGR413500
14.000	14.827	0.319	14.044	14.034	0.035	457	TGR414000
14.500	15.327	0.319	14.544	14.534	0.035	458	TGR414500
15.000	15.827	0.319	15.044	15.034	0.035	459	TGR415000
15.500	16.327	0.319	15.544	15.534	0.035	460	TGR415500
16.000	16.827	0.319	16.044	16.034	0.035	461	TGR416000
16.500	17.327	0.319	16.544	16.534	0.035	462	TGR416500

Bold print indicates Busak+Shamban Preferred Design sizes.



Table 29 Ordering Information/Internal Sealing (Imperial - Continued)

Shaft Diameter C f8	Groove Diameter D H9	Groove Width G+.008	Maximum Bore Diameter B		Radius R (Max)	O-Ring Dash No.	Turcon® Roto Glyd Ring® Part Number
			1000 psi	3000 psi			
17.000	17.827	0.319	17.044	17.034	0.035	463	TGR417000
17.500	18.327	0.319	17.544	17.534	0.035	464	TGR417500
18.000	18.827	0.319	18.044	18.034	0.035	465	TGR418000
18.500	19.327	0.319	18.544	18.534	0.035	466	TGR418500
19.000	19.827	0.319	19.044	19.034	0.035	467	TGR419000
19.500	20.327	0.319	19.544	19.534	0.035	468	TGR419500
20.000	20.827	0.319	20.043	20.033	0.035	469	TGR410000

Bold print indicates Busak+Shamban Preferred Design sizes.

Matching O-Rings may have either larger or smaller ID than the groove diameter. However, the differences shall not affect the performance and reliability of the seal once the Roto Glyd Ring® is installed properly.

Ordering Example

Turcon® Roto Glyd Ring®, internal sealing, series TG32

Rod Diameter: C = 80.0 mm
 Part No.: TG3200800 (from Table 28)

Select the material from Table 1, page 2. The corresponding code numbers are appended to the Part No. Together they form the Order Number.

Order O-Ring separately.

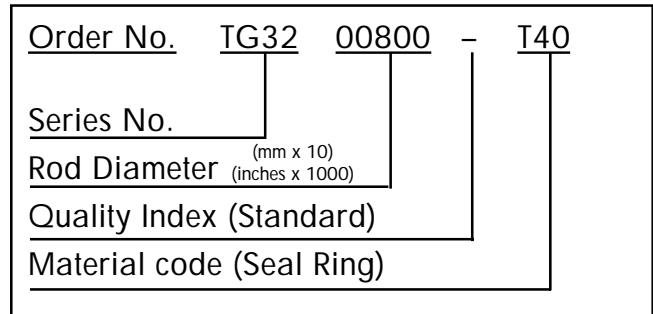



General

Description

The Turcon® Roto Variseal™ is single-acting seal consisting of a U-Shaped seal jacket and a V-shaped corrosion resistant spring.

The characteristic of the Roto Variseal™ is the flanged heel, which prevents the seal from rotating in the groove and the short and heavy dynamic lip offering reduced friction, long service life and a good scraping effect even in highly viscous media.

The Roto Variseal™ is a single-acting shaft seal which consists of an asymmetric U-Shaped seal body into which a V-shaped metallic spring is inserted as a energizing element. The seal is held axially by a flange and thus prevented from turning with the shaft.

At low and zero pressure, the metal spring provides the primary sealing force. As the system pressure increases, the main sealing force is achieved by the system pressure and ensures a tight seal from zero to high pressure.

The possibility of matching suitable materials for the seal and the spring allows use in a wide range of applications going beyond the field of hydraulics, e.g. in the chemical, pharmaceutical and food processing industries.

The Roto Variseal™ can be sterilized and is available in a special Hi-Clean version where the spring cavity is filled with a Silicone elastomer preventing contaminants from being entrapped in the seal. This design also works well in applications involving mud, slurries or adhesives to keep grit from packing into the seal cavity and inhibiting the spring action.

Advantages

- Rotary, reciprocating and static service
- Good scraping effect
- Stick-slip-free operating for precise control
- High abrasion resistance and dimensional stability
- Can handle rapid changes in temperature
- No contamination in contact with food products, pharmaceutical and medicinal fluids
- Can be sterilized
- Unlimited shelf life

Technical Data

Operating Pressure:	For dynamic loads: 15MPa (2175 psi) For static loads: 25MPa (3625 psi) Not at max. speed, please inquire.
Speed:	Rotating: up to 2 m/s (6,6 ft/s) (reciprocating up to 10 m/s (33 ft/s) Not at max. speed, please inquire.
Temperature:	-100°C to +260°C (-148°F to +500°F) For specific applications at lower temperatures, please inquire
Media:	Practically all fluids, chemicals and gases

Materials

All materials used are physiologically safe. They contain no odor or taste-affecting substances.

The following standard material combination has proved effective for most applications:

Seal ring:	Turcon® T40
Spring:	Stainless Steel Material No. AISI301

For use in accordance with the demands of the Food and Drug Administration. Suitable materials are available on request.

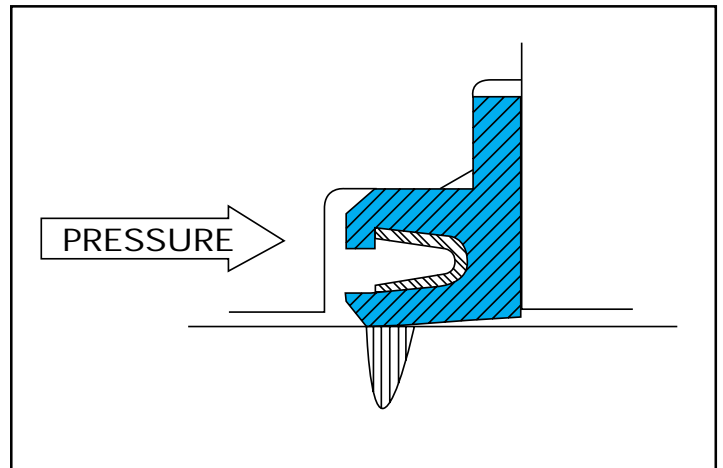

Figure 21 Turcon® Roto Variseal™ load profile



Installation Recommendations

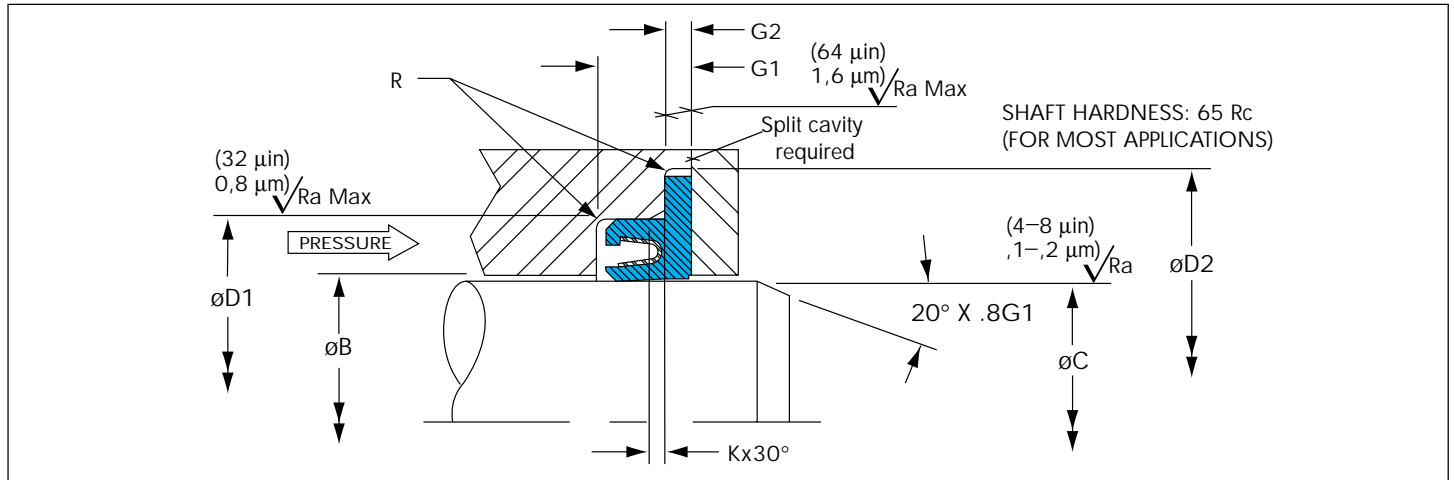

Table 30 Turcon® Roto Variseal™ Ordering Information (Metric)

Shaft Diameter C f8	Groove Diameter D1 H9	Groove Diameter D2 H10	Groove Width G1+0,2	Groove Width G2-0,15	Lead-in Chamfer K (Max)	Radius R (Max)	Maximum Bore Diameter B		Turcon® Roto Variseal™ Part Number
							10 MPa	20 MPa	
5,0	10,0	14,0	3,6	0,85	0,8	0,3	5,27	5,17	TVM100050-T40S
6,0	11,0	15,0	3,6	0,85	0,8	0,3	6,27	6,17	TVM100060-T40S
8,0	13,0	17,0	3,6	0,85	0,8	0,3	8,27	8,17	TVM100080-T40S
10,0	15,0	19,0	3,6	0,85	0,8	0,3	10,27	10,17	TVM100100-T40S
12,0	17,0	21,0	3,6	0,85	0,8	0,3	12,26	12,16	TVM100120-T40S
14,0	19,0	23,0	3,6	0,85	0,8	0,3	14,26	14,16	TVM100140-T40S
15,0	20,0	24,0	3,6	0,85	0,8	0,3	15,26	15,16	TVM100150-T40S
16,0	21,0	25,0	3,6	0,85	0,8	0,3	16,26	16,16	TVM100160-T40S
18,0	23,0	27,0	3,6	0,85	0,8	0,3	18,26	18,16	TVM100180-T40S
20,0	27,0	32,5	4,8	1,35	1,1	0,4	20,35	20,25	TVM200200-T40S
22,0	29,0	34,5	4,8	1,35	1,1	0,4	22,35	22,25	TVM200220-T40S
25,0	32,0	37,5	4,8	1,35	1,1	0,4	25,35	25,25	TVM200250-T40S
28,0	35,0	40,5	4,8	1,35	1,1	0,4	28,35	28,25	TVM200280-T40S
30,0	37,0	42,5	4,8	1,35	1,1	0,4	30,35	30,25	TVM200300-T40S
32,0	39,0	44,5	4,8	1,35	1,1	0,4	32,34	32,24	TVM200320-T40S
35,0	42,0	47,5	4,8	1,35	1,1	0,4	35,34	35,24	TVM200350-T40S
36,0	43,0	48,5	4,8	1,35	1,1	0,4	36,34	36,24	TVM200360-T40S
40,0	50,5	57,5	7,1	1,80	1,4	0,5	40,44	40,34	TVM300400-T40S
42,0	52,5	59,5	7,1	1,80	1,4	0,5	42,44	42,34	TVM300420-T40S
45,0	55,5	62,5	7,1	1,80	1,4	0,5	45,44	45,34	TVM300450-T40S

The shaft diameters printed in **bold** type conform to the recommendations of ISO 3320.



Table 30 Turcon® Roto Variseal™ Ordering Information (Metric - Continued)

Shaft Diameter C f8	Groove Diameter D1 H9	Groove Diameter D2 H10	Groove Width G1+0,2	Groove Width G2-0,15	Lead-in Chamfer K (Max)	Radius R (Max)	Maximum Bore Diameter B		Turcon® Roto Variseal™ Part Number
							10 MPa	20 MPa	
48,0	58,5	65,5	7,1	1,80	1,4	0,5	48,44	48,34	TVM300480-T40S
50,0	60,5	67,5	7,1	1,80	1,4	0,5	50,44	50,34	TVM300500-T40S
52,0	62,5	69,5	7,1	1,80	1,4	0,5	52,42	52,32	TVM300520-T40S
55,0	65,5	72,5	7,1	1,80	1,4	0,5	55,42	55,32	TVM300550-T40S
56,0	66,5	73,5	7,1	1,80	1,4	0,5	56,42	56,32	TVM300560-T40S
60,0	70,5	77,5	7,1	1,80	1,4	0,5	60,42	60,32	TVM300600-T40S
63,0	73,5	80,5	7,1	1,80	1,4	0,5	63,42	63,32	TVM300630-T40S
65,0	75,5	82,5	7,1	1,80	1,4	0,5	65,42	65,32	TVM300650-T40S
70,0	80,5	87,5	7,1	1,80	1,4	0,5	70,42	70,32	TVM300700-T40S
75,0	85,5	92,5	7,1	1,80	1,4	0,5	75,42	75,32	TVM300750-T40S
80,0	90,5	97,5	7,1	1,80	1,4	0,5	80,42	80,32	TVM300800-T40S
85,0	95,5	102,5	7,1	1,80	1,4	0,5	85,41	85,31	TVM300850-T40S
90,0	100,5	107,5	7,1	1,80	1,4	0,5	90,41	90,31	TVM300900-T40S
95,0	105,5	112,5	7,1	1,80	1,4	0,5	95,41	95,31	TVM300950-T40S
100,0	110,5	117,5	7,1	1,80	1,4	0,5	100,41	100,31	TVM301000-T40S
105,0	115,5	122,5	7,1	1,80	1,4	0,5	105,41	105,31	TVM301050-T40S
110,0	120,5	127,5	7,1	1,80	1,4	0,5	110,41	110,31	TVM301100-T40S
115,0	125,5	132,5	7,1	1,80	1,4	0,5	115,41	115,31	TVM301150-T40S
120,0	130,5	137,5	7,1	1,80	1,4	0,5	120,41	120,31	TVM301200-T40S
125,0	135,5	142,5	7,1	1,80	1,4	0,5	125,39	125,29	TVM301250-T40S
130,0	140,5	147,5	7,1	1,80	1,4	0,5	130,39	130,29	TVM301300-T40S
135,0	145,5	152,5	7,1	1,80	1,4	0,5	135,39	135,29	TVM301350-T40S
140,0	150,5	157,5	7,1	1,80	1,4	0,5	140,39	140,29	TVM301400-T40S
150,0	160,5	167,5	7,1	1,80	1,4	0,5	150,39	150,29	TVM301500-T40S
160,0	170,5	177,5	7,1	1,80	1,4	0,5	160,39	160,29	TVM301600-T40S
170,0	180,5	187,5	7,1	1,80	1,4	0,5	170,39	170,29	TVM301700-T40S
180,0	190,5	197,5	7,1	1,80	1,4	0,5	180,39	180,29	TVM301800-T40S
190,0	200,5	207,5	7,1	1,80	1,4	0,5	190,38	190,28	TVM301900-T40S
200,0	210,5	217,5	7,1	1,80	1,4	0,5	200,38	200,28	TVM302000-T40S
210,0	220,5	227,5	7,1	1,80	1,4	0,5	210,38	210,28	TVM302100-T40S
220,0	230,5	237,5	7,1	1,80	1,4	0,5	220,38	220,28	TVM302200-T40S
230,0	240,5	247,5	7,1	1,80	1,4	0,5	230,38	230,28	TVM302300-T40S
240,0	250,5	257,5	7,1	1,80	1,4	0,5	240,38	240,28	TVM302400-T40S
250,0	260,5	267,5	7,1	1,80	1,4	0,5	250,38	250,28	TVM302500-T40S
280,0	290,5	297,5	7,1	1,80	1,4	0,5	280,36	280,26	TVM302800-T40S

The shaft diameters printed in **bold** type conform to the recommendations of ISO 3320.



Table 30 Turcon® Roto Variseal™ Ordering Information (Metric - Continued)

Shaft Diameter C f8	Groove Diameter D1 H9	Groove Diameter D2 H10	Groove Width G1+0,2	Groove Width G2-0,15	Lead-in Chamfer K (Max)	Radius R (Max)	Maximum Bore Diameter B		Turcon® Roto Variseal™ Part Number
							10 MPa	20 MPa	
300,0	310,5	317,5	7,1	1,80	1,4	0,5	300,36	300,26	TVM303000-T40S
320,0	330,5	337,5	7,1	1,80	1,4	0,5	320,35	320,25	TVM303200-T40S
350,0	360,5	367,5	7,1	1,80	1,4	0,5	350,35	350,25	TVM303500-T40S
360,0	370,5	377,5	7,1	1,80	1,4	0,5	360,35	360,25	TVM303600-T40S
400,0	410,5	417,5	7,1	1,80	1,4	0,5	400,35	400,25	TVM304000-T40S
420,0	434,0	442,0	9,5	2,80	1,6	0,5	420,44	420,34	TVM404200-T40S
450,0	464,0	472,0	9,5	2,80	1,6	0,5	450,44	450,34	TVM404500-T40S
480,0	494,0	502,0	9,5	2,80	1,6	0,5	480,44	480,34	TVM404800-T40S
500,0	514,0	522,0	9,5	2,80	1,6	0,5	500,44	500,34	TVM405000-T40S
600,0	614,0	622,0	9,5	2,80	1,6	0,5	600,42	600,32	TVM406000-T40S
700,0	714,0	722,0	9,5	2,80	1,6	0,5	700,40	700,30	TVM407000-T40S

The shaft diameters printed in **bold** type conform to the recommendations of ISO 3320.

Other dimensions and all intermediate sizes up to 2500 mm diameter sizes can be supplied.

Table 31 Turcon® Roto Variseal™ Ordering Information (Imperial)

Shaft Diameter C f8	Groove Diameter D1 H9	Groove Diameter D2 H10	Groove Width G1+.10	Groove Width G2+.003	Lead-in Chamfer K (Max)	Radius R (Max)	Maximum Bore Diameter B		Turcon® Roto Variseal™ Part Number
							1000 psi	3000 psi	
.437	.625	.780	.141	.017	.030	.010	0.444	0.442	M30-MS-R-111-W109
.500	.687	.842	.141	.017	.030	.010	0.507	0.505	M30-MS-R-112-W109
.562	.750	.905	.141	.017	.030	.010	0.569	0.567	M30-MS-R-113-W109
.625	.812	.967	.141	.017	.030	.010	0.632	0.630	M30-MS-R-114-W109
.687	.875	1.030	.141	.017	.030	.010	0.694	0.692	M30-MS-R-115-W109
.750	.937	1.092	.141	.017	.030	.010	0.757	0.755	M30-MS-R-116-W109
.812	1.000	1.155	.141	.017	.030	.010	0.819	0.817	M30-MS-R-117-W109
.875	1.062	1.217	.141	.017	.030	.010	0.882	0.880	M30-MS-R-118-W109
.937	1.125	1.280	.141	.017	.030	.010	0.944	0.942	M30-MS-R-119-W109
1.000	1.187	1.342	.141	.017	.030	.010	1.007	1.005	M30-MS-R-120-W109
1.125	1.375	1.562	.188	.024	.040	.015	1.132	1.130	M30-MS-R-216-W109
1.250	1.500	1.687	.188	.024	.040	.015	1.256	1.254	M30-MS-R-218-W109
1.375	1.625	1.812	.188	.024	.040	.015	1.381	1.379	M30-MS-R-220-W109
1.500	1.750	1.937	.188	.024	.040	.015	1.506	1.504	M30-MS-R-222-W109
1.750	2.000	2.187	.188	.024	.040	.015	1.756	1.754	M30-MS-R-224-W109



Table 31 Turcon® Roto Variseal™ Ordering Information (Imperial- Continued)

Shaft Diameter C f8	Groove Diameter D1 H9	Groove Diameter D2 H10	Groove Width G1+.10	Groove Width G2+.003	Lead-in Chamfer K (Max)	Radius R (Max)	Maximum Bore Diameter B		Turcon® Roto Variseal™ Part Number
							1000 psi	3000 psi	
2.000	2.250	2.437	.188	.024	.040	.015	2.006	2.004	M30-MS-R-226-W109
2.250	2.500	2.687	.188	.024	.040	.015	2.256	2.254	M30-MS-R-228-W109
2.500	2.750	2.937	.188	.024	.040	.015	2.506	2.504	M30-MS-R-230-W109
2.750	3.000	3.187	.188	.024	.040	.015	2.756	2.754	M30-MS-R-232-W109
3.000	3.250	3.437	.188	.024	.040	.015	3.006	3.004	M30-MS-R-234-W109
3.250	3.500	3.687	.188	.024	.040	.015	3.256	3.254	M30-MS-R-236-W109
3.500	3.875	4.166	.281	.028	.055	.020	3.506	3.504	M30-MS-R-341-W109
3.750	4.125	4.416	.281	.028	.055	.020	3.756	3.754	M30-MS-R-343-W109
4.000	4.375	4.666	.281	.028	.055	.020	4.006	4.004	M30-MS-R-345-W109
4.250	4.625	4.916	.281	.028	.055	.020	4.256	4.254	M30-MS-R-347-W109
4.500	4.875	5.166	.281	.028	.055	.020	4.506	4.504	M30-MS-R-349-W109
4.750	5.125	5.416	.281	.028	.055	.020	4.756	4.754	M30-MS-R-351-W109
5.000	5.375	5.666	.281	.028	.055	.020	5.006	5.004	M30-MS-R-353-W109
5.250	5.625	5.916	.281	.028	.055	.020	5.256	5.254	M30-MS-R-355-W109
5.500	5.875	6.166	.281	.028	.055	.020	5.506	5.504	M30-MS-R-357-W109
5.750	6.125	6.416	.281	.028	.055	.020	5.756	5.754	M30-MS-R-359-W109
6.000	6.375	6.666	.281	.028	.055	.020	6.006	6.004	M30-MS-R-361-W109
6.250	6.625	6.916	.281	.028	.055	.020	6.256	6.254	M30-MS-R-362-W109
6.500	6.875	7.166	.281	.028	.055	.020	6.506	6.504	M30-MS-R-363-W109
6.750	7.250	7.572	.375	.041	.060	.020	6.756	6.754	M30-MS-R-440-W109
7.000	7.500	7.822	.375	.041	.060	.020	7.006	7.004	M30-MS-R-441-W109
7.250	7.750	8.072	.375	.041	.060	.020	7.255	7.253	M30-MS-R-442-W109
7.500	8.000	8.322	.375	.041	.060	.020	7.505	7.503	M30-MS-R-443-W109
7.750	8.250	8.572	.375	.041	.060	.020	7.755	7.753	M30-MS-R-444-W109
8.000	8.500	8.822	.375	.041	.060	.020	8.005	8.003	M30-MS-R-445-W109
8.500	9.000	9.322	.375	.041	.060	.020	8.505	8.503	M30-MS-R-446-W109
9.000	9.500	9.822	.375	.041	.060	.020	9.005	9.003	M30-MS-R-447-W109
9.500	10.000	10.322	.375	.041	.060	.020	9.505	9.503	M30-MS-R-448-W109
10.000	10.500	10.822	.375	.041	.060	.020	10.005	10.003	M30-MS-R-449-W109
10.500	11.000	11.322	.375	.041	.060	.020	10.505	10.503	M30-MS-R-450-W109
11.000	11.500	11.822	.375	.041	.060	.020	11.005	11.003	M30-MS-R-451-W109
11.500	12.000	12.322	.375	.041	.060	.020	11.505	11.503	M30-MS-R-452-W109
12.000	12.500	12.822	.375	.041	.060	.020	12.005	12.003	M30-MS-R-453-W109
12.500	13.000	13.322	.375	.041	.060	.020	12.504	12.502	M30-MS-R-454-W109
13.000	13.500	13.822	.375	.041	.060	.020	13.004	13.002	M30-MS-R-455-W109



Table 31 Turcon® Roto Variseal™ Ordering Information (Imperial- Continued)

Shaft Diameter C f8	Groove Diameter D1 H9	Groove Diameter D2 H10	Groove Width G1+.10	Groove Width G2+.003	Lead-in Chamfer K (Max)	Radius R (Max)	Maximum Bore Diameter B		Turcon® Roto Variseal™ Part Number
							1000 psi	3000 psi	
13.500	14.000	14.322	.375	.041	.060	.020	13.504	13.502	M30-MS-R-456-W109
14.000	14.500	14.822	.375	.041	.060	.020	14.004	14.002	M30-MS-R-457-W109
14.500	15.000	15.322	.375	.041	.060	.020	14.504	14.502	M30-MS-R-458-W109
15.000	15.500	15.822	.375	.041	.060	.020	15.004	15.002	M30-MS-R-459-W109
15.500	16.000	16.322	.375	.041	.060	.020	15.504	15.502	M30-MS-R-460-W109



■ Description

The Turcon® Variseal™ M2 is a single-acting seal consisting of a U-Shaped seal jacket and a V-shaped corrosion resistant spring.

The characteristic of the Variseal™ M2 is the newly developed asymmetric seal profile, where the dynamic lip has an optimized short and heavy profile, offering reduced friction and long service life.

At low and zero pressures, the metal spring provides the primary sealing force. As the system pressure increases, the main sealing force is achieved and ensures a tight seal from zero to high pressure.

The possibility of matching suitable materials for the seal and the spring enables the Turcon® Variseal™ M2 to be used in a wide range of applications going beyond the field of hydraulics, e.g. in the chemical, pharmaceutical and food processing industry.

The Variseal™ M2 can be sterilized and is available in a special Hi-Clean version where the spring cavity is filled with a silicone elastomer preventing contaminants from being entrapped in the seal. This design also works well in applications involving mud, slurries or adhesives to keep grit from packing into the seal cavity and inhibiting the spring action.

Variseal™ M2 seals can be installed in grooves to MIL-G-5514F and ISO 3771. The seal can only be installed to a limited extent in closed grooves. Installation instructions, see page 99.

The Turcon® Variseal™ M2 replaces the previous seal series: S-55601–S-55608; S-59040–S-59049; S-59060–S-59069

The Turcon® Variseal™ M2S is an alternative to the Variseal™ M2. In addition to the advantages of the Variseal™ M2, the Variseal™ M2S offers excellent scraping effect and a reciprocating and turning movement. Variseal™ M2S can be installed in grooves to MIL-G-5514F and ISO 3771.

For more information on the Variseal™ M2, please contact your Busak+Shamban representative.

Advantages

- Reciprocating and turning applications
- Resistant to most fluids and chemicals
- Low coefficients of friction
- Stick-slip-free operating for precise control
- High abrasion resistance and dimensional stability
- Can handle rapid changes in temperature
- No contamination in contact with food products, pharmaceutical and medicinal fluids
- Can be sterilized
- Unlimited shelf life

Technical Data

Operating Pressure:	For dynamic loads: 45MPa (6525 psi) For static loads: 60MPa (8700 psi)
Speed:	Reciprocating: up to 15 m/s (50 ft/s) Rotary up to 1 m/s (3.3 ft/s)
Temperature:	-70°C to +260°C (-94°F to 500°F) For specific applications at lower temperatures, please inquire
Media:	Practically all fluids, chemicals and gases
Note:	At high temperatures, pressures and speeds must be reduced.

Materials

All materials used are physiologically safe. They contain no odor or taste-affecting substances. The following standard material combination has proved effective for most applications:

Seal ring:	Turcon® T40
Spring:	S (Stainless Steel)

For use in accordance with the demands of the "Food and Drug Administration." suitable materials are available upon request.

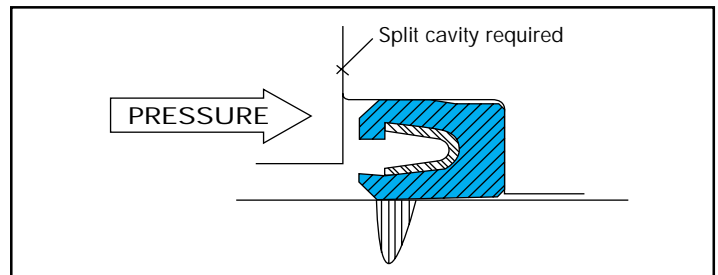

Figure 22 Turcon® Variseal™ M2 load distribution profile



Installation Recommendations for Rod

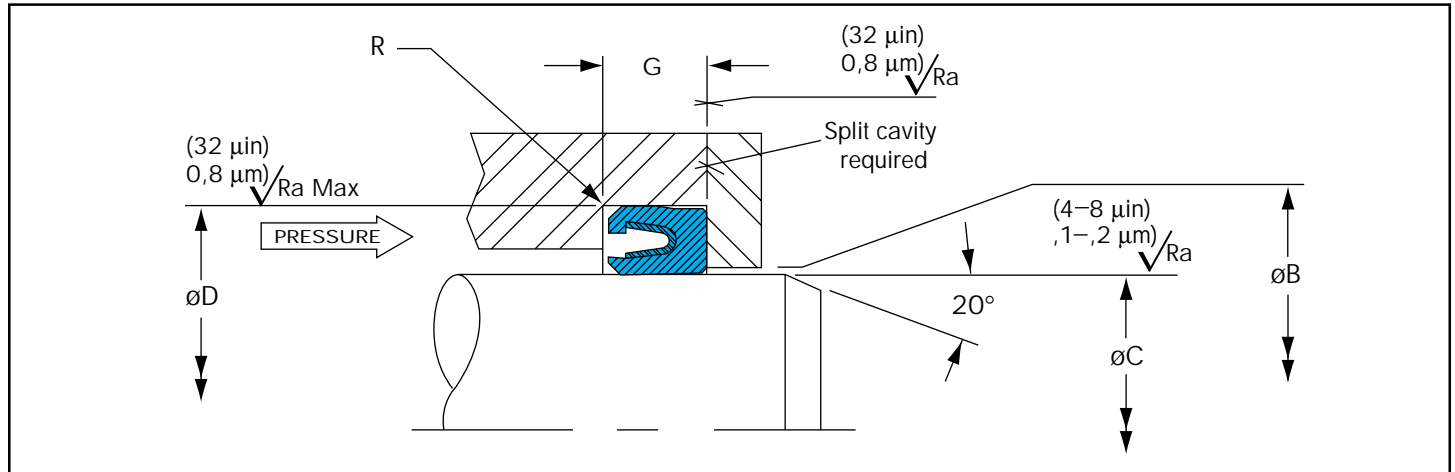

Table 32 Turcon® Variseal™ M2 Ordering Information (Metric)

Rod Diameter C f8	Groove Diameter D H9	Groove Width G+0,2	Radius R (Max)	Maximum Bore Dia B			Variseal™ Part Number
				10 MPa	20 MPa	40 MPa	
3,0	5,9	2,4	0,4	3,18	3,14	3,08	RVA000030-T40S
4,0	6,9	2,4	0,4	4,17	4,13	4,07	RVA000040-T40S
5,0	7,9	2,4	0,4	5,17	5,13	5,07	RVA000050-T40S
6,0	8,9	2,4	0,4	6,17	6,13	6,07	RVA000060-T40S
8,0	10,9	2,4	0,4	8,17	8,13	8,07	RVA000080-T40S
10,0	14,5	3,6	0,4	10,27	10,17	10,11	RVA100100-T40S
12,0	16,5	3,6	0,4	12,26	12,16	12,10	RVA100120-T40S
14,0	18,5	3,6	0,4	14,26	14,16	14,10	RVA100140-T40S
15,0	19,5	3,6	0,4	15,26	15,16	15,10	RVA100150-T40S
16,0	20,5	3,6	0,4	16,26	16,16	16,10	RVA100160-T40S
18,0	22,5	3,6	0,4	18,26	18,16	18,10	RVA100180-T40S
20,0	26,2	4,8	0,6	20,35	20,25	20,11	RVA200200-T40S
22,0	28,2	4,8	0,6	22,35	22,25	22,11	RVA200220-T40S
25,0	31,2	4,8	0,6	25,35	25,25	25,11	RVA200250-T40S
28,0	34,2	4,8	0,6	28,35	28,25	28,11	RVA200280-T40S
30,0	36,2	4,8	0,6	30,35	30,25	30,11	RVA200300-T40S
32,0	38,2	4,8	0,6	32,34	32,24	32,10	RVA200320-T40S
35,0	41,2	4,8	0,6	35,34	35,24	35,10	RVA200350-T40S
36,0	42,2	4,8	0,6	36,34	36,24	36,10	RVA200360-T40S
40,0	49,4	7,1	0,6	40,44	40,34	40,14	RVA300400-T40S

Bold type indicates the dimensions correspond to ISO 3320



Table 32 Turcon® Variseal™ M2 Ordering Information (Metric - Continued)

Rod Diameter C f8	Groove Diameter D H9	Groove Width G+0,2	Radius R (Max)	Maximum Bore Dia B			Variseal™ Part Number
				10 MPa	20 MPa	40 MPa	
42,0	51,4	7,1	0,8	42,44	42,34	42,14	RVA300420-T40S
45,0	54,4	7,1	0,8	45,44	45,34	45,14	RVA300450-T40S
48,0	57,4	7,1	0,8	48,44	48,34	48,14	RVA300480-T40S
50,0	59,4	7,1	0,8	50,44	50,34	50,14	RVA300500-T40S
52,0	61,4	7,1	0,8	52,42	52,32	52,12	RVA300520-T40S
55,0	64,4	7,1	0,8	55,42	55,32	55,12	RVA300550-T40S
56,0	65,4	7,1	0,8	56,42	56,32	56,12	RVA300560-T40S
60,0	69,4	7,1	0,8	60,42	60,32	60,12	RVA300600-T40S
63,0	72,4	7,1	0,8	63,42	63,32	63,12	RVA300630-T40S
65,0	74,4	7,1	0,8	65,42	65,32	65,12	RVA300650-T40S
70,0	79,4	7,1	0,8	70,42	70,32	70,12	RVA300700-T40S
75,0	84,4	7,1	0,8	75,42	75,32	75,12	RVA300750-T40S
80,0	89,4	7,1	0,8	80,42	80,32	80,12	RVA300800-T40S
85,0	94,4	7,1	0,8	85,41	85,31	85,11	RVA300850-T40S
90,0	99,4	7,1	0,8	90,41	90,31	90,11	RVA300900-T40S
95,0	104,4	7,1	0,8	95,41	95,31	95,11	RVA300950-T40S
100,0	109,4	7,1	0,8	100,41	100,31	100,11	RVA301000-T40S
105,0	114,4	7,1	0,8	105,41	105,31	105,11	RVA301050-T40S
110,0	119,4	7,1	0,8	110,41	110,31	110,11	RVA301100-T40S
115,0	124,4	7,1	0,8	115,41	115,31	115,11	RVA301150-T40S
120,0	132,2	9,5	0,8	120,51	120,41	120,15	RVA401200-T40S
125,0	137,2	9,5	0,8	125,49	125,39	125,13	RVA401250-T40S
130,0	142,2	9,5	0,8	130,49	130,39	130,13	RVA401300-T40S
135,0	147,2	9,5	0,8	140,49	140,39	140,13	RVA401350-T40S
140,0	152,2	9,5	0,8	145,49	145,39	145,13	RVA401400-T40S
150,0	162,2	9,5	0,8	150,49	150,39	150,13	RVA401500-T40S
160,0	172,2	9,5	0,8	160,49	160,39	160,13	RVA401600-T40S
170,0	182,2	9,5	0,8	170,49	170,39	170,13	RVA401700-T40S
180,0	192,2	9,5	0,8	180,49	180,39	180,13	RVA401800-T40S
190,0	202,2	9,5	0,8	190,48	190,38	190,12	RVA401900-T40S
200,0	212,2	9,5	0,8	200,48	200,38	200,12	RVA402000-T40S
210,0	222,2	9,5	0,8	210,48	210,38	210,12	RVA402100-T40S
220,0	232,2	9,5	0,8	220,48	220,38	220,12	RVA402200-T40S
230,0	242,2	9,5	0,8	230,48	230,38	230,12	RVA402300-T40S
240,0	252,2	9,5	0,8	240,48	240,38	240,12	RVA402400-T40S

Bold type indicates the dimensions correspond to ISO 3320



Table 32 Turcon® Variseal™ M2 Ordering Information (Metric - Continued)

Rod Diameter C f8	Groove Diameter D H9	Groove Width G+0,2	Radius R (Max)	Maximum Bore Dia B			Variseal™ Part Number
				10 MPa	20 MPa	40 MPa	
250,0	262,2	9,5	0,8	250,48	250,38	250,12	RVA402500-T40S
280,0	292,2	9,5	0,8	280,46	280,36	280,10	RVA402800-T40S
300,0	312,2	9,5	0,8	300,46	300,36	300,10	RVA403000-T40S
320,0	332,2	9,5	0,8	320,45	320,35	320,09	RVA403200-T40S
350,0	362,2	9,5	0,8	350,45	350,35	350,09	RVA403500-T40S
360,0	372,2	9,5	0,8	360,45	360,35	360,09	RVA403600-T40S
400,0	412,2	9,5	0,8	400,45	400,35	400,09	RVA404000-T40S

Bold type indicates the dimensions correspond to ISO 3320



Installation Recommendations for Bore

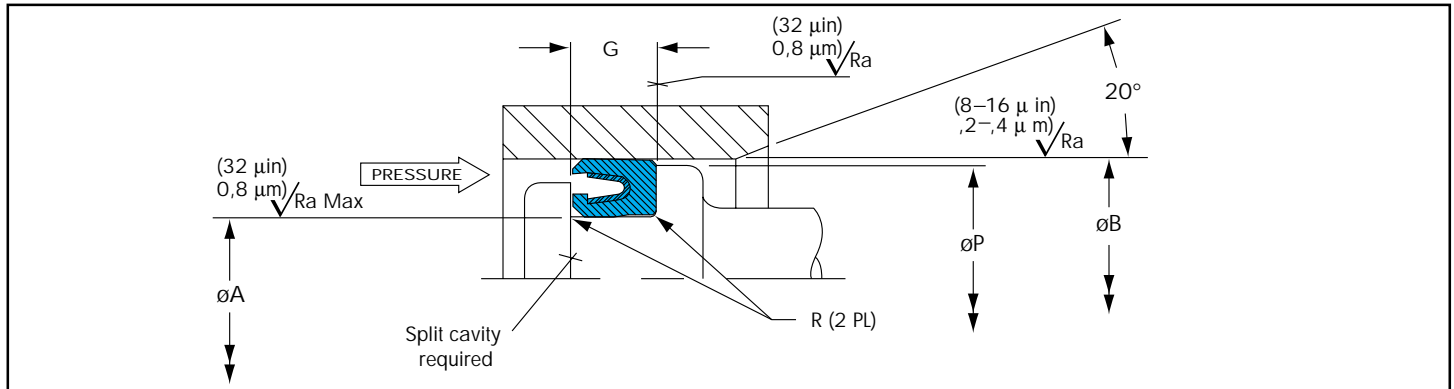

Table 33 Turcon® Variseal™ M2 Ordering Information (Metric)

Bore Diameter B H9	Groove Diameter A h9	Groove Width G+0,2	Radius R (Max)	Minimum Piston Dia P			Variseal™ Part Number
				10 MPa	20 MPa	40 MPa	
6,0	3,1	2,4	0,4	5,83	5,87	5,93	PVA000060-T40S
8,0	5,1	2,4	0,4	7,84	7,88	7,94	PVA000080-T40S
10,0	7,1	2,4	0,4	9,84	9,88	9,94	PVA000100-T40S
12,0	9,1	2,4	0,4	11,84	11,88	11,94	PVA000120-T40S
14,0	9,5	3,6	0,4	13,74	13,84	13,90	PVA100140-T40S
15,0	10,5	3,6	0,4	14,74	14,84	14,90	PVA100150-T40S
16,0	11,5	3,6	0,4	15,74	15,84	15,90	PVA100160-T40S
18,0	13,5	3,6	0,4	17,75	17,85	17,91	PVA100180-T40S
20,0	15,5	3,6	0,4	19,75	19,85	19,91	PVA100200-T40S
22,0	17,5	3,6	0,4	21,75	21,85	21,91	PVA100220-T40S
25,0	18,8	4,8	0,6	26,65	24,75	24,89	PVA200250-T40S
28,0	21,8	4,8	0,6	27,65	27,75	27,89	PVA200280-T40S
30,0	23,8	4,8	0,6	29,65	29,75	29,89	PVA200300-T40S
32,0	25,8	4,8	0,6	31,66	31,76	31,90	PVA200320-T40S
35,0	28,8	4,8	0,6	34,66	34,76	34,90	PVA200350-T40S
40,0	33,8	4,8	0,6	39,66	39,76	39,90	PVA200400-T40S
42,0	35,8	4,8	0,6	41,66	41,76	41,90	PVA200420-T40S
45,0	38,8	4,8	0,6	44,66	44,76	44,90	PVA200450-T40S
48,0	38,6	7,1	0,8	47,56	47,66	47,86	PVA300480-T40S
50,0	40,6	7,1	0,8	49,56	49,66	49,86	PVA300500-T40S
52,0	42,6	7,1	0,8	51,57	51,67	51,87	PVA300520-T40S
55,0	45,6	7,1	0,8	54,57	54,67	54,87	PVA300550-T40S
56,0	46,6	7,1	0,8	55,57	55,67	55,87	PVA300560-T40S
60,0	50,6	7,1	0,8	59,57	59,67	59,87	PVA300600-T40S
63,0	53,6	7,1	0,8	62,57	62,67	62,87	PVA300630-T40S

Bold type indicates the dimensions correspond to ISO 3320

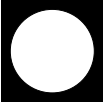

Table 33 Turcon® Variseal™ M2 Ordering Information (Metric-Continued)

Bore Diameter B H9	Groove Diameter A H9	Groove Width G+0,2	Radius R (Max)	Minimum Piston Dia P			Variseal™ Part Number
				10 MPa	20 MPa	40 MPa	
65,0	55,6	7,1	0,8	64,57	64,67	64,87	PVA300650-T40S
70,0	60,6	7,1	0,8	69,57	69,67	69,87	PVA300700-T40S
75,0	65,6	7,1	0,8	74,57	74,67	74,87	PVA300750-T40S
80,0	70,6	7,1	0,8	79,59	79,69	79,89	PVA300800-T40S
85,0	75,6	7,1	0,8	84,59	84,69	84,89	PVA300850-T40S
90,0	80,6	7,1	0,8	89,59	89,69	89,89	PVA300900-T40S
95,0	85,6	7,1	0,8	94,59	94,69	94,89	PVA300950-T40S
100,0	90,6	7,1	0,8	99,59	99,69	99,89	PVA301000-T40S
105,0	95,6	7,1	0,8	104,59	104,69	104,89	PVA301050-T40S
110,0	100,6	7,1	0,8	109,59	109,69	109,89	PVA301100-T40S
115,0	105,6	7,1	0,8	114,59	114,69	114,89	PVA301150-T40S
120,0	110,6	7,1	0,8	119,60	119,70	119,90	PVA301200-T40S
125,0	112,8	9,5	0,8	124,50	124,60	124,88	PVA401250-T40S
130,0	117,8	9,5	0,8	129,50	129,60	129,88	PVA401300-T40S
135,0	122,8	9,5	0,8	134,50	134,60	134,88	PVA401350-T40S
140,0	127,8	9,5	0,8	139,50	139,60	139,88	PVA401400-T40S
150,0	137,8	9,5	0,8	149,50	149,60	149,88	PVA401500-T40S
160,0	147,8	9,5	0,8	159,50	159,60	159,88	PVA401600-T40S
170,0	157,8	9,5	0,8	169,50	169,60	169,88	PVA401700-T40S
180,0	167,8	9,5	0,8	179,52	179,62	179,88	PVA401800-T40S
190,0	177,8	9,5	0,8	189,52	189,62	189,88	PVA401900-T40S
200,0	187,8	9,5	0,8	199,52	199,62	199,88	PVA402000-T40S
210,0	197,8	9,5	0,8	209,52	209,62	209,88	PVA402100-T40S
220,0	207,8	9,5	0,8	219,52	219,62	219,88	PVA402200-T40S
230,0	217,8	9,5	0,8	229,52	229,62	229,88	PVA402300-T40S
240,0	227,8	9,5	0,8	239,52	239,62	239,89	PVA402400-T40S
250,0	237,8	9,5	0,8	249,53	249,63	249,89	PVA402500-T40S
280,0	267,8	9,5	0,8	279,53	279,63	279,89	PVA402800-T40S
300,0	287,8	9,5	0,8	299,53	299,63	299,89	PVA403000-T40S
320,0	307,8	9,5	0,8	319,54	319,64	319,90	PVA403200-T40S
350,0	337,8	9,5	0,8	349,54	349,64	349,90	PVA403500-T40S
400,0	387,8	9,5	0,8	399,56	399,66	399,92	PVA404000-T40S
420,0	407,8	9,5	0,8	419,56	419,66	419,92	PVA404200-T40S
450,0	437,8	9,5	0,8	449,56	449,66	449,92	PVA404500-T40S
480,0	467,8	9,5	0,8	479,56	479,66	479,92	PVA404800-T40S
500,0	487,8	9,5	0,8	499,57	499,67	499,93	PVA405000-T40S

Bold type indicates the dimensions correspond to ISO

3320



■ Description

O-Rings offer the designer an efficient and economical sealing element for a wide range of different static applications.

Inexpensive production methods and ease of use have made the O-Ring the most widely used static seal.

A wide choice of elastomer materials for both standard and special applications allow the O-Ring to be used to seal practically all liquid and gaseous media.

O-Rings are vulcanized in molds and are characterized by their circular form with an annular cross section. The dimensions of the O-Ring are defined by the inside diameter d and the cross section W (Figure 23).

Cross sections of approximately 0.35 to 12 mm and inside diameters up to 5,000 mm are available.

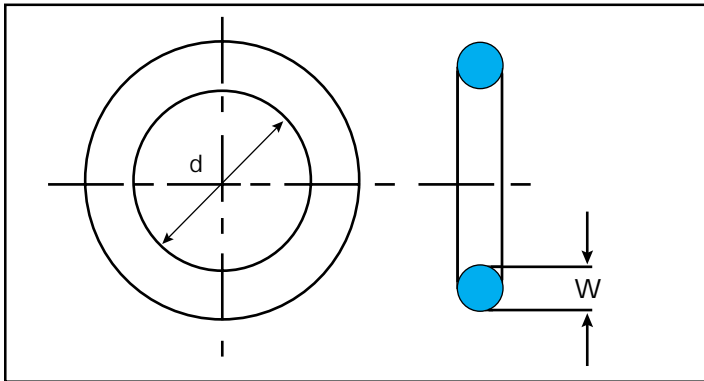

Figure 23 O-Ring dimensions

Method of Operation

O-Rings are automatic double-acting sealing elements. The initial squeeze acting in a radial or axial direction due to the installation gives the O-Ring its initial sealing capability. These forces are superimposed by the system pressure to create the total sealing force which increases with increasing system pressure (Figure 24). Under pressure, the O-Ring behaves in a similar way to a fluid with high surface tension. The pressure is transmitted uniformly to all sides.

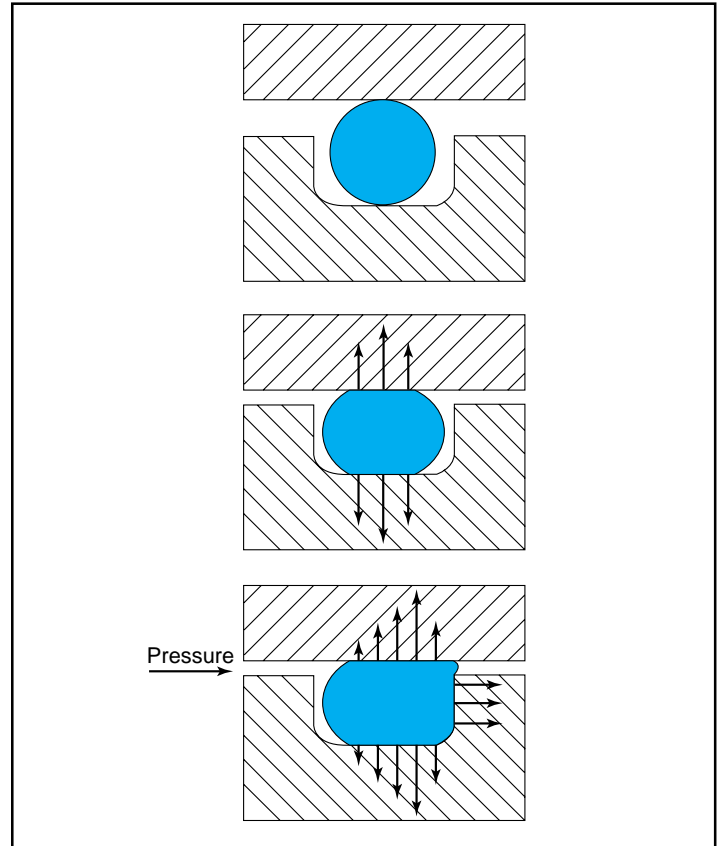

Figure 24 O-Ring sealing forces with and without system pressure

Advantages

Compared with other sealing elements, the O-Ring has a wide range of advantages:

- Inexpensive, allows low cost solutions
- Simple, one piece design reduces hardware and design costs
- Compact design allows smaller hardware
- Easy, foolproof installation reduces risk
- Applicable to a wide range of static sealing problems, single or double acting
- Wide compound choice for compatibility with most fluids
- Stock availability worldwide for easy maintenance and repair.



Fields of Application

O-Rings are used as primary static sealing elements, as energizing elements for hydraulic slipper seals and wipers and thus cover a large number of fields of application. There are no fields of industry where the O-Ring is not used. They can be used as an individual seal for repairs or maintenance to a quality assured application in aerospace, automotive or general engineering.

The O-Ring is used predominantly for static sealing applications:

- As a radial static seal, e.g. for bushings, covers, pipes and cylinders
- As an axial static seal, e.g. for flanges, plates and caps.

O-Rings in dynamic applications are not recommended because they are limited by the speed and the pressure against which they are to seal. In comparison with PTFE & polyurethane seal materials, O-Ring friction and performance characteristics are unfavorable for the majority of dynamic applications.

Technical Data

O-Rings can be used in a wide range of applications. Temperature, pressure, and media determine the choice of appropriate compounds. In order to be able to assess the suitability of the O-Ring as a sealing element for a given application, the interaction of all the operating parameters have to be taken into consideration.

Working Pressure

Static application

- up to 20 MPa (2,900 psi) without Back-up Ring
- up to 40 MPa (5,800 psi) with Back-up Ring
- up to 200 MPa (29,000 psi) with special Back-up Ring

Please note the permissible extrusion gaps.

Temperature

Depending on compound and media resistance for:

General applications: -30°C to +110°C (-22°F to +230°F)
 Special elastomers: -60°C to +316°C (-76°F to +600°F)

When assessing the application criteria, the peak and continuous operating temperature and pressure must be taken into consideration. High pressure may cause a cylinder to expand which in turn will enlarge the extrusion gap. A back-up ring must be used for such application.

Media

With the wide range of compounds now available, each with different properties, it is possible to seal against practically all liquids, gases and chemicals.

Compound

Table 36 on page 108 provides a summary of the various elastomer material groups. Busak+Shamban offers a large number of compounds within each group.

If no particular specifications are given for the compound, NBR (Nitrile Elastomer) in 70 Shore A will be supplied.

The hardness is one of the most important and most frequently quoted properties of rubber compounds; however, the values can be very misleading. The hardness cannot be regarded as a genuine measure of rigidity. Hardness calculations are measurements of minor deformations at the surface. The measured property, namely the impression at the surface, is seldom a measure of the serviceability of the sealing element or the rubber article.

Rigidity measurements, on the other hand, involve large deformations of the mass as a whole. For this reason, no correlation can be drawn between hardness and rigidity.

The hardness values and their tolerances are always based on the measurement in accordance with DIN 53505/ASTM D2240 on a test specimen and are expressed in Shore A. Hardness measurements on finished products are performed in the IRHD (International Rubber Hardness Durometer). Measurements on cross sections less than 2 mm produce inaccurate results and are therefore not permissible. In view of the different measuring instruments used, Shore A and IRHD values may differ from one another.

This is true particularly when measurements have to be performed on curved surfaces.



Tolerances

During vulcanization, elastomers are subject to dimensional changes due to shrinkage. The degree of shrinkage depends on compound, mold geometry and on the vulcanization process employed.

The following Tables, 34 and 35, show the tolerances for the Inside Diameter (d) and Cross Section (W). The tables are valid for all 70 Shore A Nitrile (NBR) elastomer compounds; other compounds may exhibit different dimensional tolerances. The tolerances normally have no influence on the function of the seals. High precision O-Rings are available if required – please contact us. O-Ring dimensions and standards not included in the tables are manufactured to tolerances according to ISO 3601/DIN 3771.

Table 34 Cross Section Tolerances.

Cross Section W	Tolerance ±
to 1,80	0,08
1,80 – 2,65	0,09
2,65 – 3,55	0,10
3,55 – 5,30	0,13
5,30 – 7,00	0,15
7,00 – 8,00	0,18
8,00 – 10,00	0,21
10,00 – 12,00	0,25

Table 35 Tolerances for O-Ring Inside Diameters d_i in Accordance with ISO 3601

Inside Diameter d	Tolerance ±
- 2,50	0,13
2,50 – 4,50	0,14
4,50 – 6,30	0,15
6,30 – 8,50	0,16
8,50 – 10,00	0,17
10,00 – 11,20	0,18
11,20 – 14,00	0,19
14,00 – 16,00	0,20
16,00 – 18,00	0,21
18,00 – 20,00	0,22
20,00 – 21,20	0,23
21,20 – 23,60	0,24
23,60 – 25,00	0,25
25,00 – 26,50	0,26
26,50 – 28,00	0,28
28,00 – 30,00	0,29
30,00 – 31,50	0,31
31,50 – 33,50	0,32
33,50 – 34,50	0,33
34,50 – 35,50	0,34
35,50 – 36,50	0,35
36,50 – 37,50	0,36
37,50 – 38,70	0,37
38,70 – 40,00	0,38
40,00 – 41,20	0,39

Inside Diameter d	Tolerance ±
41,20 – 42,50	0,42
42,50 – 43,70	0,41
43,70 – 45,00	0,42
45,00 – 46,20	0,43
46,20 – 47,20	0,44
47,20 – 48,20	0,45
48,20 – 50,00	0,46
50,00 – 51,50	0,47
51,50 – 53,00	0,48
53,00 – 54,50	0,50
54,50 – 56,00	0,51
56,00 – 58,00	0,52
58,00 – 60,00	0,54
60,00 – 61,50	0,55
61,50 – 63,00	0,56
63,00 – 65,00	0,58
65,00 – 67,00	0,59
67,00 – 69,00	0,61
69,00 – 71,00	0,63
71,00 – 73,00	0,64
73,00 – 75,00	0,66
75,00 – 77,50	0,67
77,50 – 80,00	0,69
80,00 – 82,50	0,71
82,50 – 85,00	0,73



Table 35 Tolerances for O-Ring Inside Diameters d_1 in Accordance with ISO 3601 (Continued)

Inside Diameter d	Tolerance \pm	Inside Diameter d	Tolerance \pm
85,00 - 87,50	0,75	250,00 -258,00	1,93
87,50 - 90,00	0,77	258,00 -265,00	1,98
90,00 - 92,50	0,79	265,00 -272,00	2,02
92,50 - 95,00	0,81	272,00 -280,00	2,08
95,00 - 97,50	0,83	280,00 -290,00	2,14
97,50 -100,00	0,84	290,00 -300,50	2,21
100,00 -103,00	0,87	300,00 -307,00	2,25
103,00 -106,00	0,89	307,00 -315,00	2,30
106,00 -109,00	0,91	315,00 -325,00	2,37
109,00 -112,00	0,93	325,00 -335,00	2,43
112,00 -115,00	0,95	335,00 -345,00	2,49
115,00 -118,00	0,97	345,00 -355,00	2,56
118,00 -122,00	1,00	355,00 -365,00	2,62
122,00 -125,50	1,03	365,00 -375,00	2,68
125,00 -128,00	1,05	375,00 -387,00	2,76
128,00 -132,00	1,08	387,00 -400,00	2,84
132,00 -136,00	1,10	400,00 -412,00	2,91
136,00 -140,00	1,13	412,00 -425,00	2,99
140,00 -145,00	1,17	425,00 -437,00	3,07
145,00 -150,00	1,20	437,00 -450,00	3,15
150,00 -155,00	1,24	450,00 -462,00	3,22
155,00 -160,00	1,27	462,00 -475,00	3,30
160,00 -165,00	1,31	475,00 -485,00	3,37
165,00 -170,00	1,34	485,00 -500,00	3,45
170,00 -175,00	1,38	500,00 -515,00	3,54
175,00 -180,00	1,41	515,00 -530,00	3,63
180,00 -185,00	1,44	530,00 -545,00	3,72
185,00 -190,00	1,48	545,00 -560,00	3,81
190,00 -195,00	1,51	560,00 -580,00	3,93
195,00 -200,00	1,55	580,00 -600,00	4,05
200,00 -206,00	1,59	600,00 -615,00	4,13
206,00 -212,00	1,63	615,00 -630,00	4,22
212,00 -218,00	1,67	630,00 -650,00	4,34
218,00 -224,00	1,71	650,00 -670,00	4,46
224,00 -230,00	1,75		
230,00 -236,00	1,79		
236,00 -243,00	1,83		
243,00 -250,00	1,88		

Tolerances for inside diameter $d_1 > 670$ mm are not included in the standards.

Tolerances on these diameters are approximately $\pm 0,7\%$.

**Table 36 Summary: Elastomer Materials**

Designation	Trade Name *	Abbreviation		
		ISO 1629	ASTM 1418	B+S
Nitrile Elastomer Acrylonitrile-Butadiene Elastomer	Buna N®/ Europrene N®/Hycar®/ Nipol N®/ Perbunan N®	NBR	NBR	N
Polyacrylate Elastomer	Europrene AR®/ Nipol AR®	ACM	ACM	A
Tetrafluoroethylene-Propylene Copolymer Elastomer	Aflas®	-	TFE/P**	WT
Butyl Elastomer	Esso Butyl®/ Polysar Butyl®	IIR	IIR	WI
Polychloroprene Elastomer	Baypren®/ Neoprene®	CR	CR	WC
Polysulphide Elastomer	Thiokol®	-	TWT	WY
Chlorosulphonated Polyethylene	Hypalon®	CSM	CSM	WM
Ethylene-Propylene-diene Monomer Elastomer	Dutral/Keltan®/ Vistalon®	EPDM	EPDM	E
Epichlorohydrin Elastomer	Herclor®/Hydrin	ECO	ECO	WO
Fluoroelastomer	Fluorel®/Tecnoflon®/ Viton®	FPM	FKM	V
Fluorosilicone Elastomer	Silastic®	MFQ	FVMQ	F
Natural Rubber	Natsyn®	NR	LNR	WR
Polyester Urethane Elastomer	Adiprene®/Urepan®/Vulcollan®	AU	AU	WU
Polyether Urethane Elastomer	Desmopan®	EU	EU	WU
Silicone Elastomer	Rhodorsil®/Silastic®/ Silopren®	MVQ	VMQ	S
Styrene-Butadiene Elastomer	Buna S®/Europrene®/ Polysar S®	SBR	SBR	WB
Perfluorinated Elastomer	Kalrez®/Zalak®	-	FFKPM	D
Hydrogenated Acrylonitrile-Butadiene Elastomer	Therban®/Tornac®/ Zetpol®	HNBR	HNBR	H

*Selection of registered trade names from Messrs BASF, Bayer AG, B.F. Goodrich, Chemische Werke Huls, Daikin, DuPont Dow Elastomers, DSM, Esso Chemie, Hercules, Hoechst AG, Montedison, Montefluos, Nippon Zeon, Polysar Ltd., Rhone Poulenc, 3 M Company, Wacker Chemie.

** Abbreviation not yet standardized

ASTM = American Society for Testing and Materials

ISO = International Standardization Organization



Design Recommendations

Choice of the O-Ring Size

The chosen cross section W should be in an appropriate ratio to the O-Ring inside diameter d . A minimum cross section is assigned to each inside diameter. Taking into account the tolerances, the next larger cross section is to be recommended in case of doubt. For static applications, large diameter O-Rings can safely be used with smaller cross sections.

An important parameter for assessing the sealing behavior is the compression set of the O-Ring compound. Under load, elastomers exhibit not only an elastic component but also a permanent plastic deformation (Figure 25).

The compression set is determined in accordance with DIN 53517/ASTM 395B as follows:

$$CS = \frac{h_0 - h_2}{h_0 - h_1} \cdot 100 (\%)$$

Where:

h_0 = Original height (W)

h_1 = Height in the compressed state under load

h_2 = Height after the load is removed

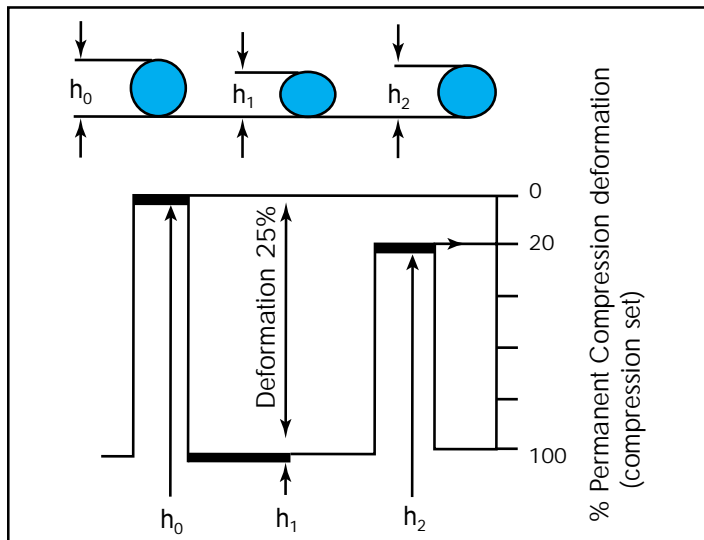

Figure 25 Illustration of the compression set

Initial Squeeze

An initial squeeze of the O-Ring in the groove is essential to ensure its function as a primary or secondary sealing element (Figure 26). It serves to:

- Achieve the initial sealing capability
- Bridge production tolerances
- Assure defined frictional forces
- Compensate for the compression set
- Compensate for wear

Depending on the application, the following values apply for the initial squeeze as a proportion of the cross section (W):

Static applications: 15 to 30%

Taking into account the tolerances of the O-Ring and the groove, minimum values are specified of 6% for hydraulics applications and 2% for pneumatic applications.

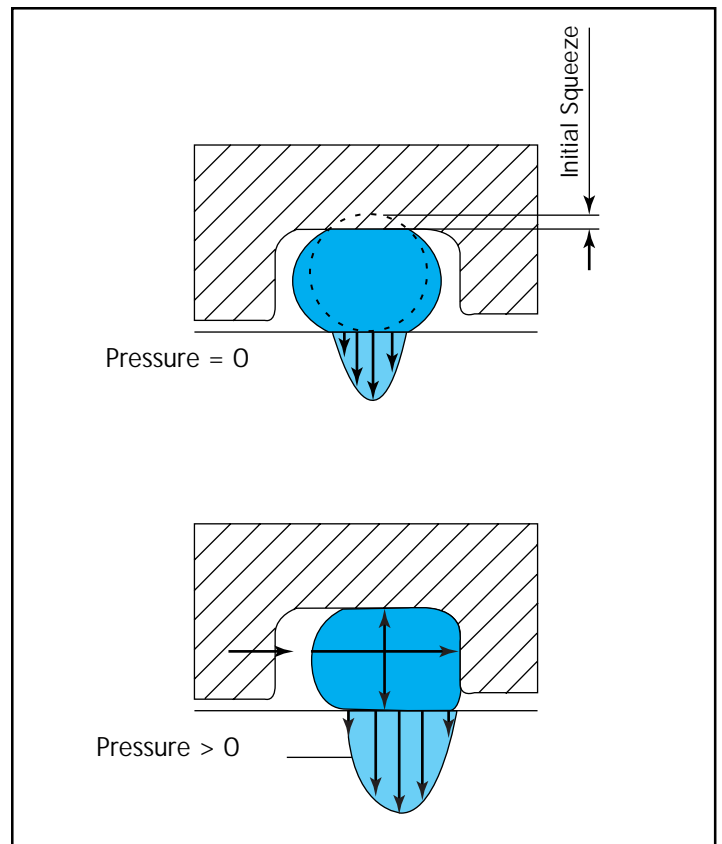

Figure 26 O-Ring contact pressure installed and under service pressure

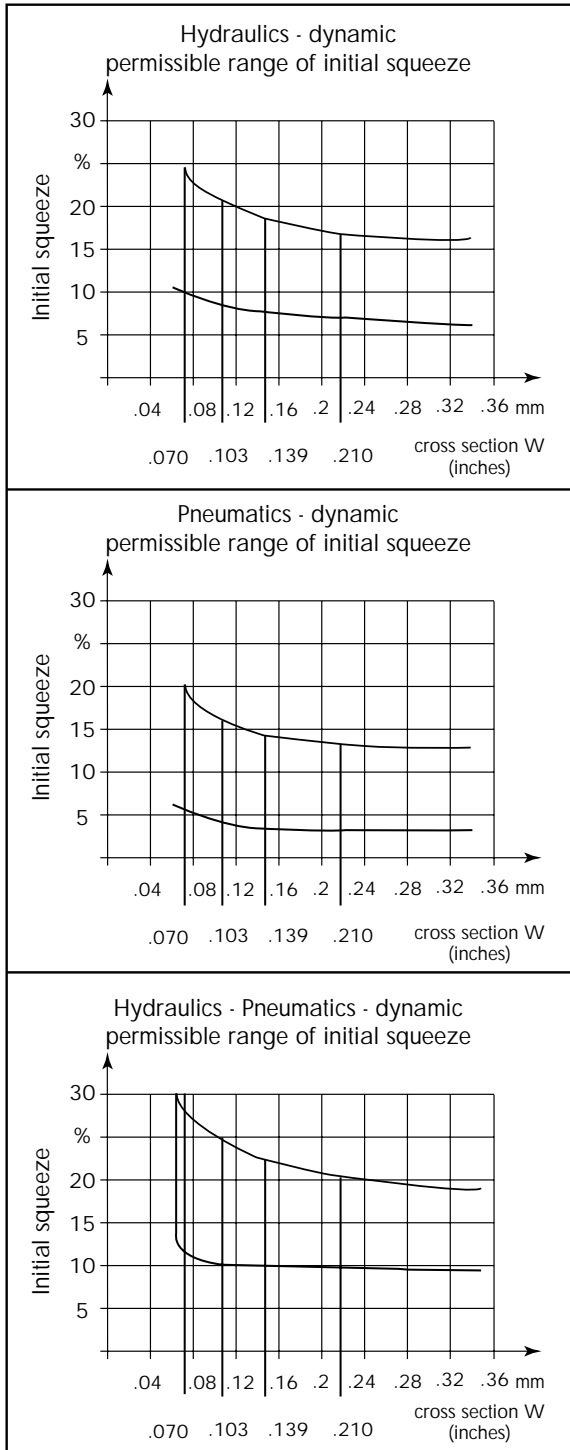

Figure 27 Initial squeeze as a function of cross section

The design of the grooves can be based on the guide values for the initial squeeze shown in the diagrams in Figure 27. These take into account the relationships between various Shore A hardnesses, loads and cross sections.

Compression forces

The deformation forces vary depending on the extent of the initial squeeze and the Shore Hardness. Figure 28 shows the specific compression force per inch of the seal circumference as a function of the cross section.

The compression forces shown can be used to estimate the total force to be applied for static installation of O-Rings.

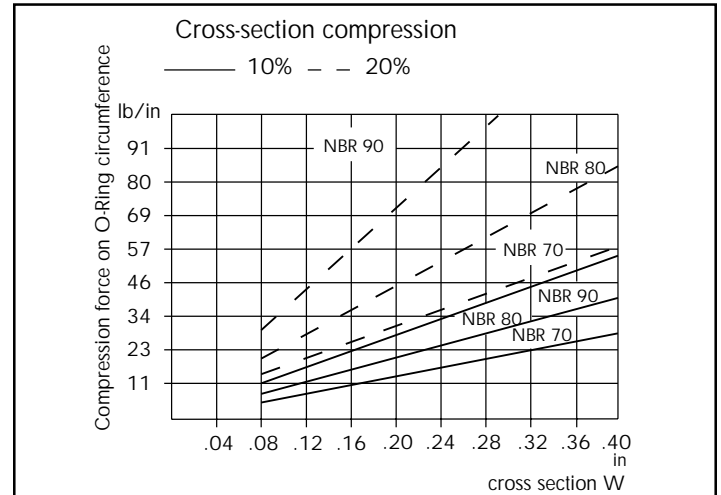

Figure 28 Compression forces on the O-Ring circumference depending on the Compound.

Elongation- Compression

With a radial sealing configuration, the O-Ring in an internal groove - "outside sealing" - should be stretched over the diameter of the groove. Maximum elongation in the installed state is 6%.

With external grooves - "inside sealing" - the O-Ring is preferably compressed along its circumference. The maximum circumferential compression in the installed state is 3%.

Exceeding these values will result in too large an increase or decrease in the O-Ring cross section. An elongation of 1% corresponds to a reduction of the cross section (W) of approximately 0.5%.



Methods of Installation

O-Rings can be used in components in a wide variety of ways.

During the design stage, installation must be taken into consideration. In order to avoid damage during installation, it should not be necessary to pass the O-Ring over edges or bores. When long sliding movements are involved, the seal hardware glands should be recessed, if possible, or the O-Rings arranged so that they only have to travel short distances during installation to reduce risk of twisting.

Radial Installation

Inner sealing

The O-Ring size should be selected so that the inside diameter d has the smallest possible deviation from the rod diameter to be sealed C (Figure 29).

Outer Sealing

The O-Ring size should be selected so that the inside diameter d is equal to or smaller than groove diameter A (Figure 29).

Axial Installation, (static)

During axial-static installation, the direction of the pressure should be taken into consideration when choosing the O-Ring size (Figure 30). With internal pressure the O-Ring should be chosen approximately 1 to 2% larger than the outer groove diameter F . With external pressure the O-Ring is chosen approximately 1 to 3% smaller than the inner groove diameter H .

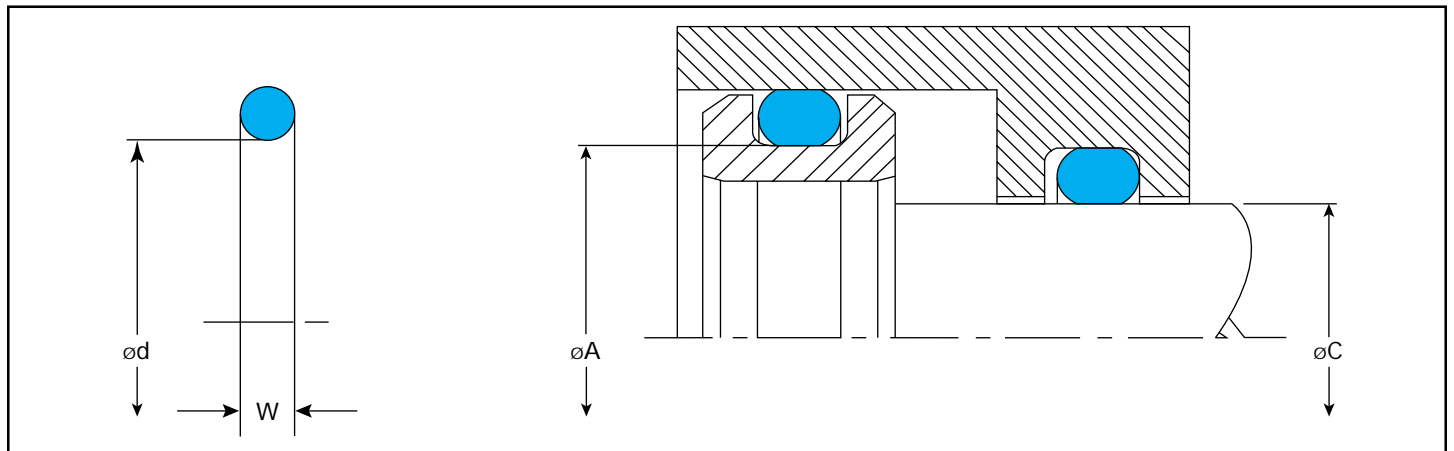

Figure 29 Radial installation

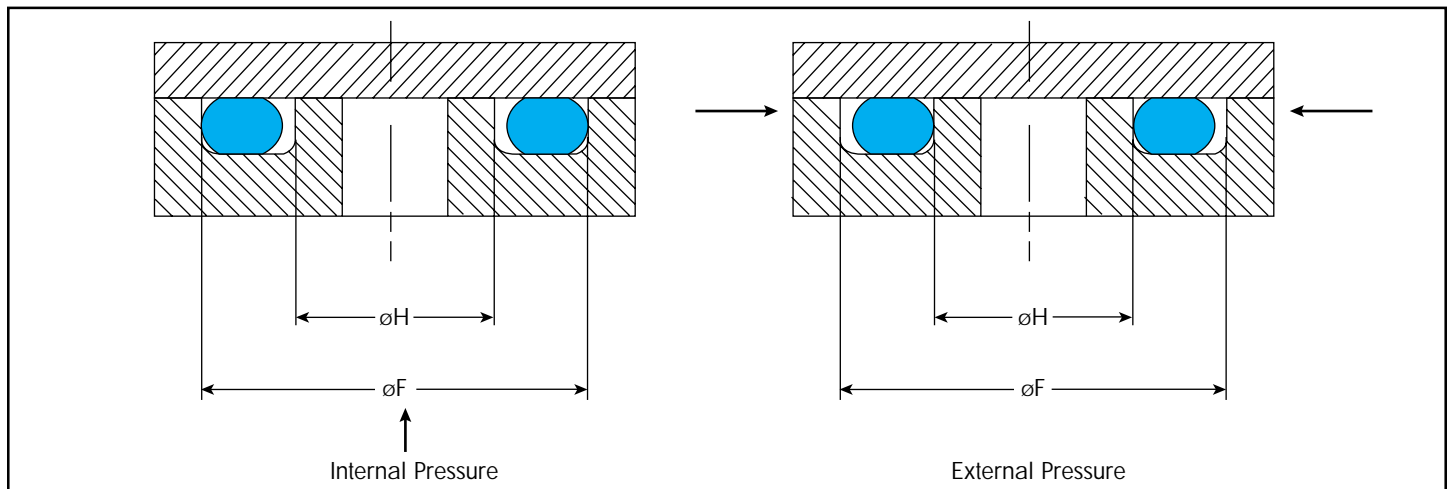
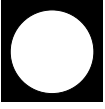

Figure 30 Axial installation, static



Groove Design

Rectangular Groove

A rectangular groove is preferred for all new designs. Designs with bevelled groove flanks up to 5° are permissible. If Back-up Rings are used, straight groove flanks are necessary. The groove widths specified in our recommendations already take into account the swelling value for O-Rings described in DIN 3771 Part 5, September 1989, whereby 15% swelling is permissible for stationary parts (Figure 31).

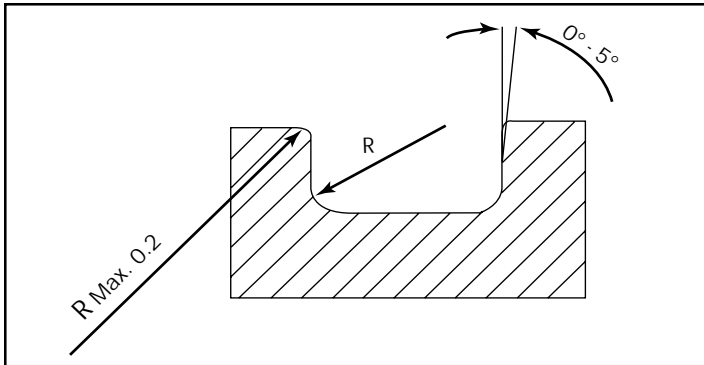

Figure 31 Groove specifications

Surfaces

Under pressure, elastomers adapt to irregular surfaces. For gas or liquid tight joints, however, certain minimum demands must be made on the surface quality of the surfaces to be sealed.

Fundamentally nicks, scratches, pit marks, concentric or spiral machining scores, etc. are not permissible.

At present, no uniform definitions exist for describing the mating surfaces. In practice, the specification of the Ra value is not sufficient to permit an assessment of the surface quality. Our recommendations therefore contain various terms and definitions in accordance with DIN 4768/1 and ISO 1302.

Surface Treatments

O-Rings can be surface treated by dipping, spraying or coating in order to reduce friction and adhesion, achieve permanent lubrication, or facilitate installation. Depending on the effect, O-Rings can also be molybdated, graphitized, powdered with talcum or coated with PTFE.

Please ask our specialists for further details.

Lead-In Chamfers

Correct design can help to eliminate possible sources of damage and seal failure from the outset.

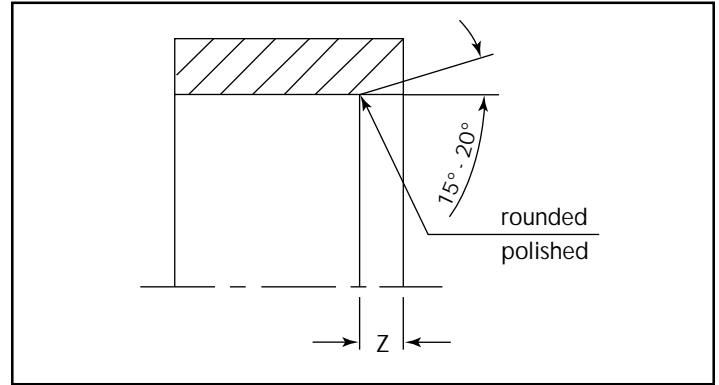

Figure 32 Lead-in chamfers for bores, tubes

Since O-Rings are squeezed during installation, lead-in Chamfers and rounded edges must be provided (Figures 32 and 33).

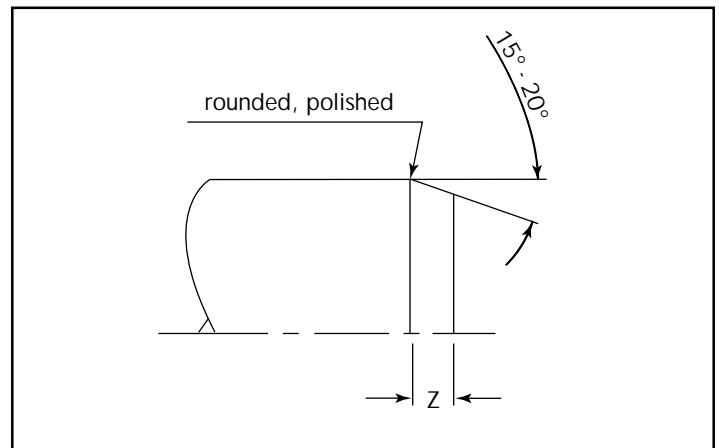

Figure 33 Lead-in chamfers for shafts, rods



The minimum lengths of the lead-in chamfers are listed in Table 37 as a function of the cross section W.

Table 37 Lead-In Chamfers

Lead-In Chamfers Length Z min	O-Ring Cross Section W
1,1	up to 1,78 1,80
1,5	up to 2,62 2,65
1,8	up to 3,53 3,55
2,7	up to 5,33 5,30
3,6	up to 7,00
4,2	up to 8,40
4,5	above 10

The permissible surface roughness of a lead-in chamfer is defined as follows:

$$R_{max} \leq 2,5 \mu\text{m} \quad R_z \leq 1,6 \mu\text{m} \quad R_a \leq 0,4 \mu\text{m}$$

Radial Clearance

The tolerances given in Table 39 and the maximum permissible radial clearance S (extrusion gap) given in Table 38 must be maintained.

If the clearance is too large, there is a risk of seal extrusion which can result in the destruction of the O-Ring (Figure 34).

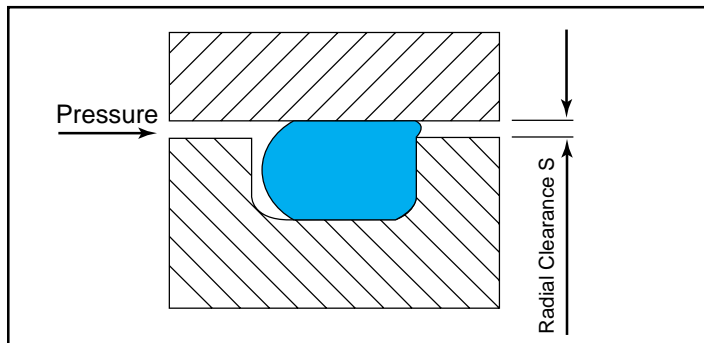

Figure 34 Radial clearance "S"

The permissible radial clearance S between the sealed parts depends on the system pressure, the cross section and the O-Ring.

Table 38 contains recommendations for the permissible clearance S as a function of the O-Ring cross section and shore hardness. The table is valid for elastomer materials with the exception of polyurethane and FEP encapsulated O-Rings.

Table 38 Radial Clearance S

O-Ring Cross Section W	up to 2	2-3	3-5	5-7	above 7
O-Rings with hardness of 70 Shore A					
Pressure MPa	Radial Clearance S				
≤ 3,50	0,08	0,09	0,10	0,13	0,15
≤ 7,00	0,05	0,07	0,08	0,09	0,10
≤ 10,50	0,03	0,04	0,05	0,07	0,08
O-Rings with hardness of 90 Shore A					
Pressure MPa	Radial Clearance S				
≤ 3,50	0,13	0,15	0,20	0,23	0,25
≤ 7,00	0,10	0,13	0,15	0,18	0,20
≤ 10,50	0,07	0,09	0,10	0,13	0,15
≤ 14,00	0,05	0,07	0,08	0,09	0,10
≤ 17,50	0,04	0,05	0,07	0,08	0,09
≤ 21,00	0,03	0,04	0,05	0,07	0,08
≤ 35,00	0,02	0,03	0,03	0,04	0,04

These values assume that the mating parts are concentric to one another and do not expand under pressure. If this is not the case, the clearance should be kept correspondingly smaller.



O-Ring Installation with Back-up Rings

Another possible method of protecting the O-Ring from extrusion into the sealing gap is the additional installation of Back-up Rings. Back-up Rings are recommended for pressure above approximately 5 MPa (725 psi) or systems with large sealing gaps.

A complete summary of our Back-up Ring product range can be found in the catalog "Back-up Rings". The following tables offer the designer a preferred series. They permit easy selection and the assignment of the Back-up Rings to the O-Ring sizes and/or groove dimensions.

The selection series contains two Back-up Ring types:

- Split design, preferred for outside sealing applications (bore)
- One-piece design, preferred for inside sealing applications (rod) and with split grooves.

The compounds for the O-Ring selection series can be found in the compound list, Table 41, page 128. The standard compound for the Back-up Rings is pure, unfilled PTFE. Special compounds e.g. for injection molded Back-up Rings, on request.

Installation Instructions

General Instructions

Before starting installation, check the following points:

- Lead-in chamfers made according to drawing?
- Inner bores deburred and edges rounded?
- Machining residues, e.g. chips, dirt and foreign particles removed?
- Screw thread tips covered?
- Seals and components greased or oiled? Ensure media compatibility with the elastomer material
- Do not use lubricants with solid additives, e.g. molybdenum disulfide or zinc sulfide.

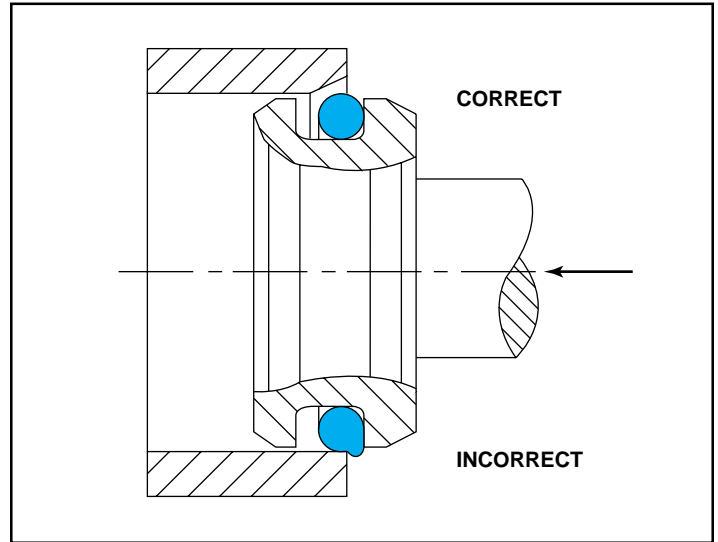

Figure 35 Piston installation with O-Ring

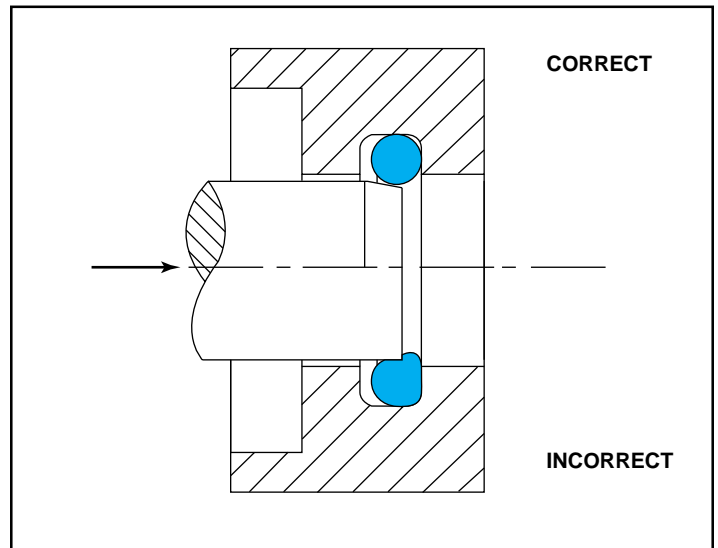

Figure 36 Rod installation with O-Ring

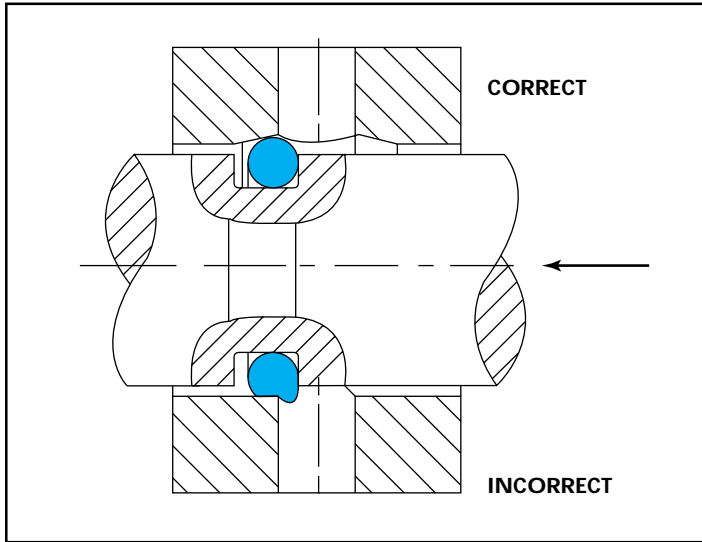
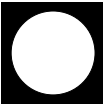

Figure 37 O-Ring installation over transverse bores

Installation by Hand

- Use no sharp tools!
- Ensure that the O-Ring is not twisted, use installation aids, e.g. thread, to assist correct positioning (Figure 38)
- Use installation aids whenever possible
- Do not overstretch O-Rings
- Do not stretch butt-vulcanized O-Rings at the joint.

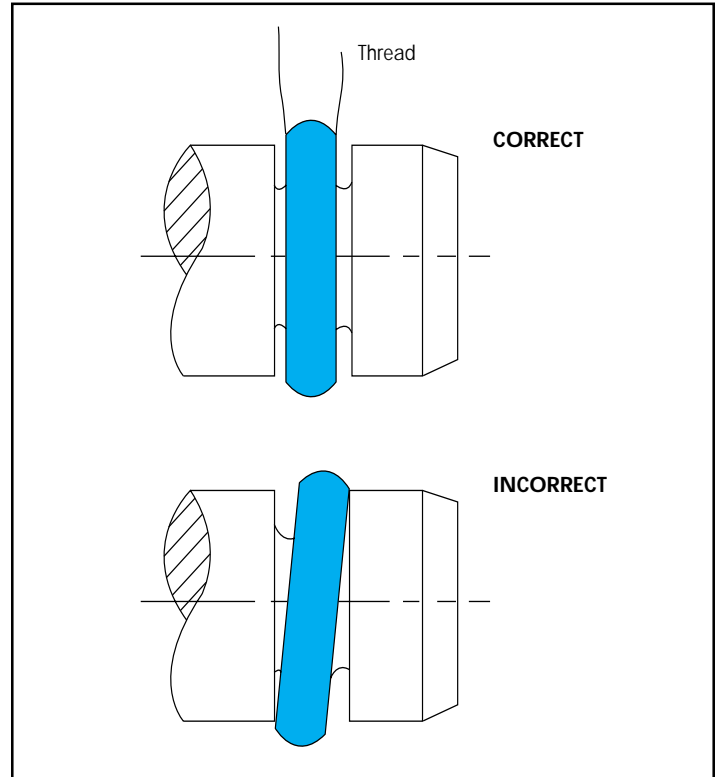

Figure 38 O-Ring installation using a thread

Automatic Installation

Automatic O-Ring installation requires good preparation. The surfaces of the O-Rings are frequently treated by molycoating, graphitizing, powdering with talcum or coating with PTFE. This offers a number of benefits during installation such as a reduction in the installation forces required. It also allows for non-stick effects and easy removal.

The handling and installation of dimensionally unstable components requires a great deal of experience. Reliable automated installation thus demands special handling and packing of the O-Rings.

Please ask our specialists for further details.



Installation Recommendations

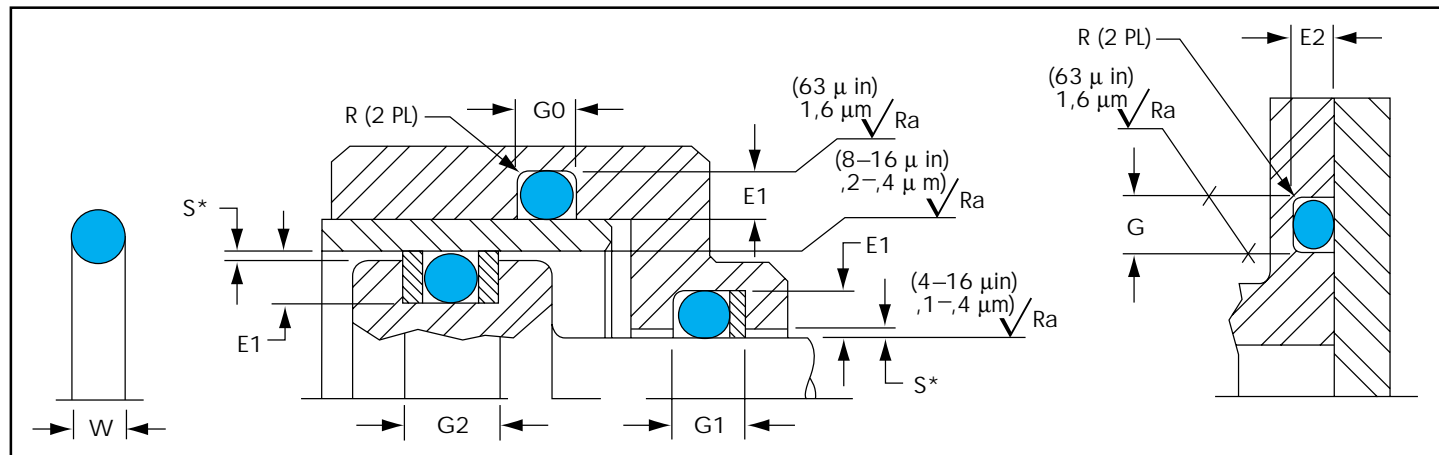

*See Table 38 on page 113 for Radial Gap S values

Table 39 Installation Dimensions for Static Applications

ARP Series	Cross Section W	Radial Installation				Axial Installation		Radius
		Groove Depth E1 + 0,05	Groove Width			Groove Depth E2 + 0,05	Groove Width G + 0,2	Without BU Ring R (Max)
			G0 + 0,2	G1 + 0,2	G2 + 0,2			
000	1,78	1,30	2,40	3,80	5,20	1,30	2,60	0,40
	1,80	1,30	2,40	3,80	5,20	1,30	2,60	0,40
	1,90	1,40	2,60	4,00	5,40	1,40	2,70	0,40
	2,40	1,80	3,20	4,60	6,00	1,80	3,30	0,50
100	2,62	2,00	3,60	5,00	6,40	2,00	3,80	0,60
	2,65	2,00	3,60	5,00	6,40	2,00	3,80	0,60
	3,10	2,40	4,10	5,50	6,90	2,40	4,10	0,60
200	3,50	2,65	4,60	6,00	7,40	2,65	4,70	0,60
	3,53	2,70	4,80	6,20	7,60	2,70	5,00	0,80
	3,55	2,70	4,80	6,20	7,60	2,70	5,00	0,80
300	5,33	4,30	7,10	8,80	10,50	4,30	7,30	1,20
	5,30	4,30	7,10	8,80	10,50	4,30	7,30	1,20
	5,70	4,60	7,20	8,90	10,60	4,60	7,40	1,20
400	6,99	5,80	9,50	12,00	14,50	5,80	9,70	1,50
	7,00	5,80	9,50	12,00	14,50	5,80	9,70	1,50
	8,40	7,10	10,00	12,50	15,00	7,10	10,30	1,50

The installation dimensions apply to NBR O-Rings. For elastomers with larger mold shrinkage, such as VMQ or FKM, the groove depth may have to be reduced. In such cases, please contact us!

For further details, please refer to our catalog, "Back-up Rings."

The installation dimensions given in this table correspond to the recommendations in DIN 3771, Part 5. The groove width can be reduced by approximately 15% if no particularly large swelling (>10%) is to be expected. The same applies to pneumatics applications.



Metric Sizes and International Standards

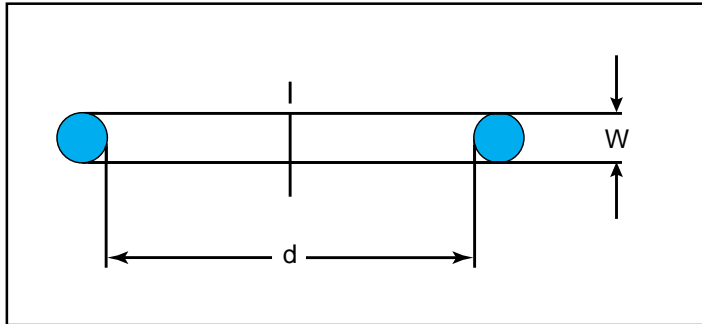

Figure 39 O-Ring dimensions

The abbreviations in the "Standard" column have the following meanings:

- DIN/ISO = DIN 3771/ISO 3601
- ARP = American standard AS 568A
British standard BS 1806
- P/G = Japanese standard JIS B 2401

Table 40 O-Ring Ordering Information (Metric)

Dimensions d x W	Part No.	Standard	Dimensions d x W	Part No.	Standard
0,74 x 1,02	ORAR00001	ARP	4,87 x 1,80	ORIA00487	DIN/ISO
1,07 x 1,27	ORAR00002	ARP	4,90 x 1,90	OR1900490	P4
1,24 x 2,62	ORAR00102	ARP	5,00 x 1,80	ORIA00500	DIN/ISO
1,42 x 1,52	ORAR00003	ARP	5,15 x 1,80	ORIA00515	DIN/ISO
1,78 x 1,78	ORAR00004	ARP	5,23 x 2,62	ORAR00107	ARP
1,80 x 1,80	ORIA00180	DIN/ISO	5,28 x 1,78	ORAR00009	ARP
2,00 x 1,80	ORIA00200	DIN/ISO	5,30 x 1,80	ORIA00530	DIN/ISO
2,06 x 2,62	ORAR00103	ARP	5,60 x 1,80	ORIA00560	DIN/ISO
2,24 x 1,80	ORIA00224	DIN/ISO	5,80 x 1,90	OR1900580	P6
2,50 x 1,80	ORIA00250	DIN/ISO	5,94 x 3,53	ORAR00202	ARP
2,57 x 1,78	ORAR00005	ARP	6,00 x 1,80	ORIA00600	DIN/ISO
2,80 x 1,80	ORIA00280	DIN/ISO	6,02 x 2,62	ORAR00108	ARP
2,80 x 1,90	OR1900280	P3	6,07 x 1,78	ORAR00010	ARP
2,84 x 2,62	ORAR00104	ARP	6,30 x 1,80	ORIA00630	DIN/ISO
2,90 x 1,78	ORAR00006	ARP	6,70 x 1,80	ORIA00670	DIN/ISO
3,15 x 1,80	ORIA00315	DIN/ISO	6,80 x 1,90	OR1900680	P7
3,55 x 1,80	ORIA00355	DIN/ISO	6,90 x 1,80	ORIA00690	DIN/ISO
3,63 x 2,62	ORAR00105	ARP	7,10 x 1,80	ORIA00710	DIN/ISO
3,68 x 1,78	ORAR00007	ARP	7,50 x 1,80	ORIA00750	DIN/ISO
3,80 x 1,90	OR1900380	P4	7,52 x 3,53	ORAR00203	ARP
4,00 x 1,80	ORIA00400	DIN/ISO	7,59 x 2,62	ORAR00109	ARP
4,34 x 3,53	ORAR00201	ARP	7,65 x 1,78	ORAR00011	ARP
4,42 x 2,62	ORAR00106	ARP	7,80 x 1,90	OR1900780	P8
4,47 x 1,78	ORAR00008	ARP	8,00 x 1,80	ORIA00800	DIN/ISO
4,50 x 1,80	ORIA00450	DIN/ISO	8,50 x 1,80	ORIA00850	DIN/ISO



Table 40 O-Ring Ordering Information (Metric - Continued)

Dimensions d x W	Part No.	Standard	Dimensions d x W	Part No.	Standard
8,76 x 1,80	ORIA00876	DIN/ISO	15,24 x 5,33	ORAR00312	ARP
8,80 x 1,90	OR1900880	P9	15,47 x 3,53	ORAR00208	ARP
9,00 x 1,80	ORIA00900	DIN/ISO	15,54 x 2,62	ORAR00114	ARP
9,12 x 3,53	ORAR00204	ARP	15,60 x 1,78	ORAR00016	ARP
9,19 x 2,62	ORAR00110	ARP	15,80 x 2,40	OR2401580	P16
9,25 x 1,78	ORAR00012	ARP	16,00 x 1,80	ORIA01600	DIN/ISO
9,50 x 1,80	ORIA00950	DIN/ISO	16,00 x 2,65	ORIB01600	DIN/ISO
9,80 x 1,90	OR1900980	P10	16,81 x 5,33	ORAR00313	ARP
9,80 x 2,40	OR2400980	P10A	17,00 x 1,80	ORIA01700	DIN/ISO
10,00 x 1,80	ORIA01000	DIN/ISO	17,00 x 2,65	ORIB01700	DIN/ISO
10,46 x 5,33	ORAR00309	ARP	17,04 x 3,53	ORAR00209	ARP
10,60 x 1,80	ORIA01060	DIN/ISO	17,12 x 2,62	ORAR00115	ARP
10,69 x 3,53	ORAR00205	ARP	17,17 x 1,78	ORAR00017	ARP
10,77 x 2,62	ORAR00111	ARP	17,80 x 2,40	OR2401780	P18
10,80 x 2,40	OR2401080	P11	18,00 x 2,65	ORIB01800	DIN/ISO
10,82 x 1,78	ORAR00013	ARP	18,00 x 3,55	ORIC01800	DIN/ISO
11,00 x 2,40	OR2401100	P11.2	18,42 x 5,33	ORAR00314	ARP
11,20 x 1,80	ORIA01120	DIN/ISO	18,64 x 3,53	ORAR00210	ARP
11,80 x 1,80	ORIA01180	DIN/ISO	18,72 x 2,62	ORAR00116	ARP
11,80 x 2,40	OR2401180	P12	18,77 x 1,78	ORAR00018	ARP
12,07 x 5,33	ORAR00310	ARP	19,00 x 2,65	ORIB01900	DIN/ISO
12,29 x 3,53	ORAR00206	ARP	19,00 x 3,55	ORIC01900	DIN/ISO
12,30 x 2,40	OR2401230	P12.5	19,80 x 2,40	OR2401980	P20
12,37 x 2,62	ORAR00112	ARP	19,99 x 5,33	ORAR00315	ARP
12,42 x 1,78	ORAR00014	ARP	20,00 x 2,65	ORIB02000	DIN/ISO
12,50 x 1,80	ORIA01250	DIN/ISO	20,00 x 3,55	ORIC02000	DIN/ISO
13,20 x 1,80	ORIA01320	DIN/ISO	20,22 x 3,53	ORAR00211	ARP
13,64 x 5,33	ORAR00311	ARP	20,29 x 2,62	ORAR00117	ARP
13,80 x 2,40	OR2401380	P14	20,35 x 1,78	ORAR00019	ARP
13,87 x 3,53	ORAR00207	ARP	20,80 x 2,40	OR2402080	P21
13,94 x 2,62	ORAR00113	ARP	21,20 x 2,65	ORIB02120	DIN/ISO
14,00 x 1,78	ORAR00015	ARP	21,20 x 3,55	ORIC02120	DIN/ISO
14,00 x 1,80	ORIA01400	DIN/ISO	21,59 x 5,33	ORAR00316	ARP
14,00 x 2,65	ORIB01400	DIN/ISO	21,70 x 3,50	OR3502170	P22A
14,80 x 2,40	OR2401480	P15	21,80 x 2,40	OR2402180	P22
15,00 x 1,80	ORIA01500	DIN/ISO	21,82 x 3,53	ORAR00212	ARP
15,00 x 2,65	ORIB01500	DIN/ISO	21,89 x 2,62	ORAR00118	ARP



Table 40 O-Ring Ordering Information (Metric - Continued)

Dimensions d x W	Part No.	Standard	Dimensions d x W	Part No.	Standard
21,95 x 1,78	ORAR00020	ARP	29,51 x 5,33	ORAR00321	ARP
22,10 x 3,50	OR3502210	P22.4	29,70 x 3,50	OR3502970	P30
22,40 x 2,62	ORIB02240	DIN/ISO	29,74 x 3,53	ORAR00217	ARP
22,40 x 3,55	ORIC02240	DIN/ISO	29,82 x 2,62	ORAR00123	ARP
23,16 x 5,33	ORAR00317	ARP	29,87 x 1,78	ORAR00025	ARP
23,39 x 3,53	ORAR00213	ARP	30,00 x 2,65	ORIB03000	DIN/ISO
23,47 x 2,62	ORAR00119	ARP	30,00 x 3,55	ORIC03000	DIN/ISO
23,52 x 1,78	ORAR00021	ARP	30,70 x 3,50	OR3503070	P31
23,60 x 2,65	ORIB02360	DIN/ISO	31,12 x 5,33	ORAR00322	ARP
23,60 x 3,55	ORIC02360	DIN/ISO	31,20 x 3,50	OR3503120	P31.5
23,70 x 3,50	OR3502370	P24	31,34 x 3,53	ORAR00218	ARP
24,40 x 3,10	OR3102440	G25	31,42 x 2,62	ORAR00124	ARP
24,70 x 3,50	OR3502470	P25	31,47 x 1,78	ORAR00026	ARP
24,77 x 5,33	ORAR00318	ARP	31,50 x 2,65	ORIB03150	DIN/ISO
24,99 x 3,53	ORAR00214	ARP	31,50 x 3,55	ORIC03150	DIN/ISO
25,00 x 2,65	ORIB02500	DIN/ISO	31,70 x 3,50	OR3503170	P32
25,00 x 3,55	ORIC02500	DIN/ISO	32,50 x 2,65	ORIB03250	DIN/ISO
25,07 x 2,62	ORAR00120	ARP	32,50 x 3,55	ORIC03250	DIN/ISO
25,12 x 1,78	ORAR00022	ARP	32,69 x 5,33	ORAR00323	ARP
25,20 x 3,50	OR3502520	P25.5	32,92 x 3,53	ORAR00219	ARP
25,70 x 3,50	OR3502570	P26	32,99 x 2,62	ORAR00125	ARP
25,80 x 2,65	ORIB02580	DIN/ISO	33,05 x 1,78	ORAR00027	ARP
25,80 x 3,55	ORIC02580	DIN/ISO	33,50 x 2,65	ORIB03350	DIN/ISO
26,34 x 5,33	ORAR00319	ARP	33,50 x 3,55	ORIC03350	DIN/ISO
26,57 x 3,53	ORAR00215	ARP	33,70 x 3,50	OR3503370	P34
26,64 x 2,62	ORAR00121	ARP	34,29 x 5,33	ORAR00324	ARP
26,70 x 1,78	ORAR00023	ARP	34,40 x 3,10	OR3103440	G35
27,70 x 3,50	OR3502770	P28	34,50 x 2,65	ORIB03450	DIN/ISO
27,94 x 5,33	ORAR00320	ARP	34,50 x 3,55	ORIC03450	DIN/ISO
28,00 x 2,65	ORIB02800	DIN/ISO	34,52 x 3,53	ORAR00220	ARP
28,00 x 3,55	ORIC02800	DIN/ISO	34,59 x 2,62	ORAR00126	ARP
28,17 x 3,53	ORAR00216	ARP	34,65 x 1,78	ORAR00028	ARP
28,24 x 2,62	ORAR00122	ARP	34,70 x 3,50	OR3503470	P35
28,30 x 1,78	ORAR00024	ARP	35,20 x 3,50	OR3503520	P35.5
28,70 x 3,50	OR3502870	P29	35,50 x 2,65	ORIB03550	DIN/ISO
29,20 x 3,50	OR3502920	P29.5	35,50 x 3,55	ORIC03550	DIN/ISO
29,40 x 3,10	OR3102940	G30	35,70 x 3,50	OR3503570	P36



Table 40 O-Ring Ordering Information (Metric - Continued)

Dimensions d x W	Part No.	Standard	Dimensions d x W	Part No.	Standard
36,09 x 3,53	ORAR00221	ARP	44,40 x 3,10	OR3104440	G45
36,17 x 2,62	ORAR00127	ARP	44,70 x 3,50	OR3504470	P45
36,50 x 2,65	ORIB03650	DIN/ISO	45,00 x 3,55	ORIC04500	DIN/ISO
36,50 x 3,55	ORIC03650	DIN/ISO	45,00 x 5,30	ORID04500	DIN/ISO
37,47 x 5,33	ORAR00325	ARP	45,69 x 2,62	ORAR00133	ARP
37,50 x 2,65	ORIB03750	DIN/ISO	45,70 x 3,50	OR3504570	P46
37,50 x 3,55	ORIC03750	DIN/ISO	46,20 x 3,55	ORIC04620	DIN/ISO
37,69 x 3,53	ORAR00222	ARP	46,20 x 5,30	ORID04620	DIN/ISO
37,70 x 3,50	OR3503770	P38	46,99 x 5,33	ORAR00328	ARP
37,77 x 2,62	ORAR00128	ARP	47,22 x 3,53	ORAR00225	ARP
37,82 x 1,78	ORAR00029	ARP	47,29 x 2,62	ORAR00134	ARP
38,70 x 2,65	ORIB03870	DIN/ISO	47,35 x 1,78	ORAR00032	ARP
38,70 x 3,50	OR3503870	P39	47,50 x 3,55	ORIC04750	DIN/ISO
38,70 x 3,55	ORIC03870	DIN/ISO	47,50 x 5,30	ORID04750	DIN/ISO
39,34 x 2,62	ORAR00129	ARP	47,60 x 5,70	OR5704760	P48A
39,40 x 3,10	OR3103940	G40	47,70 x 3,50	OR3504770	P48
39,70 x 3,50	OR3503970	P40	48,70 x 3,50	OR3504870	P49
40,00 x 3,55	ORIC04000	DIN/ISO	48,70 x 3,55	ORIC04870	DIN/ISO
40,00 x 5,30	ORID04000	DIN/ISO	48,70 x 5,30	ORID04870	DIN/ISO
40,64 x 5,33	ORAR00326	ARP	48,90 x 2,62	ORAR00135	ARP
40,70 x 3,50	OR3504070	P41	49,40 x 3,10	OR3104940	G50
40,87 x 3,53	ORAR00223	ARP	49,60 x 5,70	OR5704960	P50A
40,94 x 2,62	ORAR00130	ARP	49,70 x 3,50	OR3504970	P50
41,00 x 1,78	ORAR00030	ARP	50,00 x 3,55	ORIC05000	DIN/ISO
41,20 x 3,55	ORIC04120	DIN/ISO	50,00 x 5,30	ORID05000	DIN/ISO
41,20 x 5,30	ORID04120	DIN/ISO	50,17 x 5,33	ORAR00329	ARP
41,70 x 3,50	OR3504170	P42	50,39 x 3,53	ORAR00226	ARP
42,50 x 3,55	ORIC04250	DIN/ISO	50,47 x 2,62	ORAR00136	ARP
42,50 x 5,30	ORID04250	DIN/ISO	50,52 x 1,78	ORAR00033	ARP
42,52 x 2,62	ORAR00131	ARP	51,50 x 3,55	ORIC05150	DIN/ISO
43,70 x 3,50	OR3504370	P44	51,50 x 5,30	ORID05150	DIN/ISO
43,70 x 3,55	ORIC04370	DIN/ISO	51,60 x 5,70	OR5705160	P52
43,70 x 5,30	ORID04370	DIN/ISO	52,07 x 2,62	ORAR00137	ARP
43,82 x 5,33	ORAR00327	ARP	52,60 x 5,70	OR5705260	P53
44,04 x 3,53	ORAR00224	ARP	53,00 x 3,55	ORIC05300	DIN/ISO
44,12 x 2,62	ORAR00132	ARP	53,00 x 5,30	ORID05300	DIN/ISO
44,17 x 1,78	ORAR00031	ARP	53,34 x 5,33	ORAR00330	ARP



Table 40 O-Ring Ordering Information (Metric - Continued)

Dimensions d x W	Part No.	Standard	Dimensions d x W	Part No.	Standard
53,57 x 3,53	ORAR00227	ARP	63,22 x 1,78	ORAR00037	ARP
53,64 x 2,62	ORAR00138	ARP	64,40 x 3,10	OR3106440	G65
53,70 x 1,78	ORAR00034	ARP	64,60 x 5,70	OR5706460	P65
54,40 x 3,10	OR3105440	G55	64,77 x 2,62	ORAR00145	ARP
54,50 x 3,55	ORIC05450	DIN/ISO	65,00 x 3,55	ORIC06500	DIN/ISO
54,50 x 5,30	ORID05450	DIN/ISO	65,00 x 5,30	ORID06500	DIN/ISO
54,60 x 5,70	OR5705460	P55	66,04 x 5,33	ORAR00334	ARP
55,25 x 2,62	ORAR00139	ARP	66,27 x 3,53	ORAR00231	ARP
55,60 x 5,70	OR5705560	P56	66,34 x 2,62	ORAR00146	ARP
56,00 x 3,55	ORIC05600	DIN/ISO	66,40 x 1,78	ORAR00038	ARP
56,00 x 5,30	ORID05600	DIN/ISO	66,60 x 5,70	OR5706660	P67
56,52 x 5,33	ORAR00331	ARP	67,00 x 3,55	ORIC06700	DIN/ISO
56,74 x 3,53	ORAR00228	ARP	67,00 x 5,30	ORID06700	DIN/ISO
56,82 x 2,62	ORAR00140	ARP	67,95 x 2,62	ORAR00147	ARP
56,87 x 1,78	ORAR00035	ARP	69,00 x 3,55	ORIC06900	DIN/ISO
57,60 x 5,70	OR5705760	P58	69,00 x 5,30	ORID06900	DIN/ISO
58,00 x 3,55	ORIC05800	DIN/ISO	69,22 x 5,33	ORAR00335	ARP
58,00 x 5,30	ORID05800	DIN/ISO	69,40 x 3,10	OR3106940	G70
58,42 x 2,62	ORAR00141	ARP	69,44 x 3,53	ORAR00232	ARP
59,40 x 3,10	OR3105940	G60	69,52 x 2,62	ORAR00148	ARP
59,60 x 5,70	OR5705960	P60	69,57 x 1,78	ORAR00039	ARP
59,69 x 5,33	ORAR00332	ARP	69,60 x 5,70	OR5706960	P70
59,92 x 3,53	ORAR00229	ARP	70,60 x 5,70	OR5707060	P71
59,99 x 2,62	ORAR00142	ARP	71,00 x 3,55	ORIC07100	DIN/ISO
60,00 x 3,55	ORIC06000	DIN/ISO	71,00 x 5,30	ORID07100	DIN/ISO
60,00 x 5,30	ORID06000	DIN/ISO	71,12 x 2,62	ORAR00149	ARP
60,05 x 1,78	ORAR00036	ARP	72,39 x 5,33	ORAR00336	ARP
61,50 x 3,55	ORIC06150	DIN/ISO	72,62 x 3,53	ORAR00233	ARP
61,50 x 5,30	ORID06150	DIN/ISO	72,69 x 2,62	ORAR00150	ARP
61,60 x 2,62	ORAR00143	ARP	72,75 x 1,78	ORAR00040	ARP
61,60 x 5,70	OR5706160	P62	73,00 x 3,55	ORIC07300	DIN/ISO
62,60 x 5,70	OR5706260	P63	73,00 x 5,30	ORID07300	DIN/ISO
62,87 x 5,33	ORAR00333	ARP	74,40 x 3,10	OR3107440	G75
63,00 x 3,55	ORIC06300	DIN/ISO	74,60 x 5,70	OR5707460	P75
63,00 x 5,30	ORID06300	DIN/ISO	75,00 x 3,55	ORIC07500	DIN/ISO
63,09 x 3,53	ORAR00230	ARP	75,00 x 5,30	ORID07500	DIN/ISO
63,17 x 2,62	ORAR00144	ARP	75,57 x 5,33	ORAR00337	ARP



Table 40 O-Ring Ordering Information (Metric - Continued)

Dimensions d x W	Part No.	Standard	Dimensions d x W	Part No.	Standard
75,79 x 3,53	ORAR00234	ARP	94,40 x 3,10	OR3109440	G95
75,87 x 2,62	ORAR00151	ARP	94,60 x 5,70	OR5709460	P95
75,92 x 1,78	ORAR00041	ARP	94,62 x 5,33	ORAR00343	ARP
77,50 x 3,55	ORIC07750	DIN/ISO	94,84 x 3,53	ORAR00240	ARP
77,50 x 5,30	ORID07750	DIN/ISO	94,92 x 2,62	ORAR00154	ARP
78,74 x 5,33	ORAR00338	ARP	94,97 x 1,78	ORAR00044	ARP
78,97 x 3,53	ORAR00235	ARP	95,00 x 3,55	ORIC09500	DIN/ISO
79,40 x 3,10	OR3107940	G80	95,00 x 5,30	ORID09500	DIN/ISO
79,60 x 5,70	OR5707960	P80	97,50 x 3,55	ORIC09750	DIN/ISO
80,00 x 3,55	ORIC08000	DIN/ISO	97,50 x 5,30	ORID09750	DIN/ISO
80,00 x 5,30	ORID08000	DIN/ISO	97,79 x 5,33	ORAR00344	ARP
81,92 x 5,33	ORAR00339	ARP	98,02 x 3,53	ORAR00241	ARP
82,14 x 3,53	ORAR00236	ARP	99,40 x 3,10	OR3109940	G100
82,22 x 2,62	ORAR00152	ARP	99,60 x 5,70	OR5709960	P100
82,27 x 1,78	ORAR00042	ARP	100,00 x 3,55	ORIC10000	DIN/ISO
82,50 x 3,55	ORIC08250	DIN/ISO	100,00 x 5,30	ORID10000	DIN/ISO
82,50 x 5,30	ORID08250	DIN/ISO	100,97 x 5,33	ORAR00345	ARP
84,40 x 3,10	OR3108440	G85	101,19 x 3,53	ORAR00242	ARP
84,60 x 5,70	OR5708460	P85	101,27 x 2,62	ORAR00155	ARP
85,00 x 3,55	ORIC08500	DIN/ISO	101,32 x 1,78	ORAR00045	ARP
85,00 x 5,30	ORID08500	DIN/ISO	101,60 x 5,70	OR5710160	P102
85,09 x 5,33	ORAR00340	ARP	103,00 x 3,55	ORIC10300	DIN/ISO
85,32 x 3,53	ORAR00237	ARP	103,00 x 5,30	ORID10300	DIN/ISO
87,50 x 3,55	ORIC08750	DIN/ISO	104,14 x 5,33	ORAR00346	ARP
87,50 x 5,30	ORID08750	DIN/ISO	104,37 x 3,53	ORAR00243	ARP
88,27 x 5,33	ORAR00341	ARP	104,40 x 3,10	OR3110440	G105
88,49 x 3,53	ORAR00238	ARP	104,60 x 5,70	OR5710460	P105
88,57 x 2,62	ORAR00153	ARP	106,00 x 3,55	ORIC10600	DIN/ISO
88,62 x 1,78	ORAR00043	ARP	106,00 x 5,30	ORID10600	DIN/ISO
89,40 x 3,10	OR3108940	G90	107,32 x 5,33	ORAR00347	ARP
89,60 x 5,70	OR5708960	P90	107,54 x 3,53	ORAR00244	ARP
90,00 x 3,55	ORIC09000	DIN/ISO	107,62 x 2,62	ORAR00156	ARP
90,00 x 5,30	ORID09000	DIN/ISO	107,67 x 1,78	ORAR00046	ARP
91,44 x 5,33	ORAR00342	ARP	109,00 x 3,55	ORIC10900	DIN/ISO
91,67 x 3,53	ORAR00239	ARP	109,00 x 5,30	ORID10900	DIN/ISO
92,50 x 3,55	ORIC09250	DIN/ISO	109,40 x 3,10	OR3110940	G110
92,50 x 5,30	ORID09250	DIN/ISO	109,60 x 5,70	OR5710960	P110



Table 40 O-Ring Ordering Information (Metric - Continued)

Dimensions d x W	Part No.	Standard	Dimensions d x W	Part No.	Standard
110,49 x 5,33	ORAR00348	ARP	126,59 x 3,53	ORAR00250	ARP
110,72 x 3,53	ORAR00245	ARP	126,67 x 2,62	ORAR00159	ARP
111,60 x 5,70	OR5711160	P112	126,72 x 1,78	ORAR00049	ARP
112,00 x 3,55	ORIC11200	DIN/ISO	128,00 x 3,55	ORIC12800	DIN/ISO
112,00 x 5,30	ORID11200	DIN/ISO	128,00 x 5,30	ORID12800	DIN/ISO
113,67 x 5,33	ORAR00349	ARP	129,40 x 3,10	OR3112940	G130
113,67 x 7,00	ORAR00425	ARP	129,54 x 5,33	ORAR00354	ARP
113,89 x 3,53	ORAR00246	ARP	129,54 x 7,00	ORAR00430	ARP
113,97 x 2,62	ORAR00157	ARP	129,60 x 5,70	OR5712960	P130
114,02 x 1,78	ORAR00047	ARP	129,77 x 3,53	ORAR00251	ARP
114,40 x 3,10	OR3111440	G115	131,60 x 5,70	OR5713160	P132
114,60 x 5,70	OR5711460	P115	132,00 x 3,55	ORIC13200	DIN/ISO
115,00 x 3,55	ORIC11500	DIN/ISO	132,00 x 5,30	ORID13200	DIN/ISO
115,00 x 5,30	ORID11500	DIN/ISO	132,72 x 5,33	ORAR00355	ARP
116,84 x 5,33	ORAR00350	ARP	132,72 x 7,00	ORAR00431	ARP
116,84 x 7,00	ORAR00426	ARP	132,94 x 3,53	ORAR00252	ARP
117,07 x 3,53	ORAR00247	ARP	133,02 x 2,62	ORAR00160	ARP
118,00 x 3,55	ORIC11800	DIN/ISO	133,07 x 1,78	ORAR00050	ARP
118,00 x 5,30	ORID11800	DIN/ISO	134,40 x 3,10	OR3113440	G135
119,40 x 3,10	OR3111940	G120	134,60 x 5,70	OR5713460	P135
119,60 x 5,70	OR5711960	P120	135,89 x 5,33	ORAR00356	ARP
120,02 x 5,33	ORAR00351	ARP	135,89 x 7,00	ORAR00432	ARP
120,02 x 7,00	ORAR00427	ARP	136,00 x 3,55	ORIC13600	DIN/ISO
120,24 x 3,53	ORAR00248	ARP	136,00 x 5,30	ORID13600	DIN/ISO
120,32 x 2,62	ORAR00158	ARP	136,12 x 3,53	ORAR00253	ARP
120,37 x 1,78	ORAR00048	ARP	139,07 x 5,33	ORAR00357	ARP
122,00 x 3,55	ORIC12200	DIN/ISO	139,07 x 7,00	ORAR00433	ARP
122,00 x 5,30	ORID12200	DIN/ISO	139,29 x 3,53	ORAR00254	ARP
123,19 x 5,33	ORAR00352	ARP	139,37 x 2,62	ORAR00161	ARP
123,19 x 7,00	ORAR00428	ARP	139,40 x 3,10	OR3113940	G140
123,42 x 3,53	ORAR00249	ARP	139,60 x 5,70	OR5713960	P140
124,40 x 3,10	OR3112440	G125	140,00 x 3,55	ORIC14000	DIN/ISO
124,60 x 5,70	OR5712460	P125	140,00 x 5,30	ORID14000	DIN/ISO
125,00 x 3,55	ORIC12500	DIN/ISO	142,24 x 5,33	ORAR00358	ARP
125,00 x 5,30	ORID12500	DIN/ISO	142,24 x 7,00	ORAR00434	ARP/R62
126,37 x 5,33	ORAR00353	ARP	142,47 x 3,53	ORAR00255	ARP
126,37 x 7,00	ORAR00429	ARP	144,40 x 3,10	OR3114440	G145

**Table 40 O-Ring Ordering Information (Metric - Continued)**

Dimensions d x W	Part No.	Standard	Dimensions d x W	Part No.	Standard
144,60 x 5,70	OR5714460	P145	165,00 x 3,55	ORIC16500	DIN/ISO
145,00 x 3,55	ORIC14500	DIN/ISO	165,00 x 5,30	ORID16500	DIN/ISO
145,00 x 5,30	ORID14500	DIN/ISO	169,30 x 5,70	OR5716930	G170
145,42 x 5,33	ORAR00359	ARP	169,50 x 8,40	OR8416950	P170
145,42 x 7,00	ORAR00435	ARP	170,00 x 3,55	ORIC17000	DIN/ISO
145,64 x 3,53	ORAR00256	ARP	170,00 x 5,30	ORID17000	DIN/ISO
145,72 x 2,62	ORAR00162	ARP	170,82 x 5,33	ORAR00364	ARP
148,49 x 5,33	ORAR00360	ARP	170,82 x 7,00	ORAR00440	ARP
148,59 x 7,00	ORAR00436	ARP	171,04 x 3,53	ORAR00261	ARP
148,82 x 3,53	ORAR00257	ARP	171,12 x 2,62	ORAR00166	ARP
149,30 x 5,70	OR5714930	G150	174,30 x 5,70	OR5717430	G175
149,50 x 8,40	OR8414950	P150A	174,50 x 8,40	OR8417450	P175
149,60 x 5,70	OR5714960	P150	175,00 x 3,55	ORIC17500	DIN/ISO
150,00 x 3,55	ORIC15000	DIN/ISO	175,00 x 5,30	ORID17500	DIN/ISO
150,00 x 5,30	ORID15000	DIN/ISO	177,17 x 5,33	ORAR00365	ARP
151,77 x 5,33	ORAR00361	ARP	177,17 x 7,00	ORAR00441	ARP
151,77 x 7,00	ORAR00437	ARP	177,39 x 3,53	ORAR00262	ARP
151,99 x 3,53	ORAR00258	ARP	177,47 x 2,62	ORAR00167	ARP
152,07 x 2,62	ORAR00163	ARP	179,30 x 5,70	OR5717930	G180
154,30 x 5,70	OR5715430	G155	179,50 x 8,40	OR8417950	P180
154,50 x 8,40	OR8415450	P155	180,00 x 3,55	ORIC18000	DIN/ISO
155,00 x 3,55	ORIC15500	DIN/ISO	180,00 x 5,30	ORID18000	DIN/ISO
155,00 x 5,30	ORID15500	DIN/ISO	183,52 x 5,33	ORAR00366	ARP
158,12 x 5,33	ORAR00362	ARP	183,52 x 7,00	ORAR00442	ARP
158,12 x 7,00	ORAR00438	ARP	183,74 x 3,53	ORAR00263	ARP
158,34 x 3,53	ORAR00259	ARP	183,82 x 2,62	ORAR00168	ARP
158,42 x 2,62	ORAR00164	ARP	184,30 x 5,70	OR5718430	G185
159,30 x 5,70	OR5715930	G160	184,50 x 8,40	OR8418450	P185
159,50 x 8,40	OR8415950	P160	185,00 x 3,55	ORIC18500	DIN/ISO
160,00 x 3,55	ORIC16000	DIN/ISO	185,00 x 5,30	ORID18500	DIN/ISO
160,00 x 5,30	ORID16000	DIN/ISO	189,30 x 5,70	OR5718930	G190
164,30 x 5,70	OR5716430	G165	189,50 x 8,40	OR8418950	P190
164,47 x 5,33	ORAR00363	ARP	189,87 x 5,33	ORAR00367	ARP
164,47 x 7,00	ORAR00439	ARP	189,87 x 7,00	ORAR00443	ARP
164,50 x 8,40	OR8416450	P165	190,00 x 3,55	ORIC19000	DIN/ISO
164,69 x 3,53	ORAR00260	ARP	190,00 x 5,30	ORID19000	DIN/ISO
164,77 x 2,62	ORAR00165	ARP	190,09 x 3,53	ORAR00264	ARP



Table 40 O-Ring Ordering Information (Metric - Continued)

Dimensions d x W	Part No.	Standard	Dimensions d x W	Part No.	Standard
190,17 x 2,62	ORAR00169	ARP	221,62 x 5,33	ORAR00372	ARP
194,30 x 5,70	OR5719430	G195	221,84 x 3,53	ORAR00269	ARP
194,50 x 8,40	OR8419450	P195	221,92 x 2,62	ORAR00174	ARP
195,00 x 3,55	ORIC19500	DIN/ISO	224,00 x 5,30	ORID22400	DIN/ISO
195,00 x 5,30	ORIC19500	DIN/ISO	224,00 x 7,00	ORIE22400	DIN/ISO
196,22 x 5,33	ORAR00368	ARP	224,50 x 8,40	OR8422450	P225
196,22 x 7,00	ORAR00444	ARP	227,97 x 5,33	ORAR00373	ARP
196,44 x 3,53	ORAR00265	ARP	227,97 x 7,00	ORAR00447	ARP
196,52 x 2,62	ORAR00170	ARP	228,19 x 3,53	ORAR00270	ARP
199,30 x 5,70	OR5719930	G200	228,27 x 2,62	ORAR00175	ARP
199,50 x 8,40	OR8419950	P200	229,30 x 5,70	OR5722930	G230
200,00 x 3,55	ORIC20000	DIN/ISO	229,50 x 8,40	OR8422950	P230
200,00 x 5,30	ORID20000	DIN/ISO	230,00 x 5,30	ORID23000	DIN/ISO
202,57 x 5,33	ORAR00369	ARP	230,00 x 7,00	ORIE23000	DIN/ISO
202,57 x 7,00	ORAR00445	ARP	234,32 x 5,33	ORAR00374	ARP
202,79 x 3,53	ORAR00266	ARP	234,50 x 8,40	OR8423450	P235
202,87 x 2,62	ORAR00171	ARP	234,54 x 3,53	ORAR00271	ARP
204,50 x 8,40	OR8420450	P205	234,62 x 2,62	ORAR00176	ARP
206,00 x 5,30	ORID20600	DIN/ISO	236,00 x 5,30	ORID23600	DIN/ISO
206,00 x 7,00	ORIE20600	DIN/ISO	236,00 x 7,00	ORIE23600	DIN/ISO
208,50 x 8,40	OR8420850	P209	239,30 x 5,70	OR5723930	G240
208,92 x 5,33	ORAR00370	ARP	239,50 x 8,40	OR8423950	P240
209,14 x 3,53	ORAR00267	ARP	240,67 x 5,33	ORAR00375	ARP
209,22 x 2,62	ORAR00172	ARP	240,67 x 7,00	ORAR00448	ARP
209,30 x 5,70	OR5720930	G210	240,89 x 3,53	ORAR00272	ARP
209,50 x 8,40	OR8420950	P210	240,97 x 2,62	ORAR00177	ARP
212,00 x 5,30	ORID21200	DIN/ISO	243,00 x 5,30	ORID24300	DIN/ISO
212,00 x 7,00	ORIE21200	DIN/ISO	243,00 x 7,00	ORIE24300	DIN/ISO
214,50 x 8,40	OR8421450	P215	244,50 x 8,40	OR8424450	P245
215,27 x 5,33	ORAR00371	ARP	247,02 x 5,33	ORAR00376	ARP
215,27 x 7,00	ORAR00446	ARP	247,24 x 3,53	ORAR00273	ARP
215,49 x 3,53	ORAR00268	ARP	247,32 x 2,62	ORAR00178	ARP
215,57 x 2,62	ORAR00173	ARP	249,30 x 5,70	OR5724930	G250
218,00 x 5,30	ORID21800	DIN/ISO	249,50 x 8,40	OR8424950	P250
218,00 x 7,00	ORIE21800	DIN/ISO	250,00 x 7,00	ORIE25000	DIN/ISO
219,30 x 5,70	OR5721930	G220	253,37 x 5,33	ORAR00377	ARP
219,50 x 8,40	OR8421950	P220	253,37 x 7,00	ORAR00449	ARP

**Table 40 O-Ring Ordering Information (Metric - Continued)**

Dimensions d x W	Part No.	Standard	Dimensions d x W	Part No.	Standard
253,59 x 3,53	ORAR00274	ARP	304,17 x 5,33	ORAR00381	ARP
254,50 x 8,40	OR8425450	P255	304,17 x 7,00	ORAR00453	ARP
258,00 x 5,30	ORID25800	DIN/ISO	304,39 x 3,53	ORAR00278	ARP
258,00 x 7,00	ORIE25800	DIN/ISO	307,00 x 5,30	ORID30700	DIN/ISO
259,30 x 5,70	OR5725930	G260	307,00 x 7,00	ORIE30700	DIN/ISO
259,50 x 8,40	OR8425950	P260	314,50 x 8,40	OR8431450	P315
264,50 x 8,40	OR8426450	P265	315,00 x 5,30	ORID31500	DIN/ISO
265,00 x 5,30	ORID26500	DIN/ISO	315,00 x 7,00	ORIE31500	DIN/ISO
265,00 x 7,00	ORIE26500	DIN/ISO	316,87 x 7,00	ORAR00454	ARP
266,07 x 5,33	ORAR00378	ARP	319,50 x 8,40	OR8431950	P320
266,07 x 7,00	ORAR00450	ARP	325,00 x 5,30	ORID32500	DIN/ISO
266,29 x 3,53	ORAR00275	ARP	325,00 x 7,00	ORIE32500	DIN/ISO
269,30 x 5,70	OR5726930	G270	329,57 x 5,33	ORAR00382	ARP
269,50 x 8,40	OR8426950	P270	329,57 x 7,00	ORAR00455	ARP
272,00 x 5,30	ORID27200	DIN/ISO	329,79 x 3,53	ORAR00279	ARP
272,00 x 7,00	ORIE27200	DIN/ISO	334,50 x 8,40	OR8433450	P335
274,50 x 8,40	OR8427450	P275	335,00 x 5,30	ORID33500	DIN/ISO
278,77 x 5,33	ORAR00379	ARP	335,00 x 7,00	ORIE33500	DIN/ISO
278,77 x 7,00	ORAR00451	ARP	339,50 x 8,40	OR8433950	P340
278,99 x 3,53	ORAR00276	ARP	342,27 x 7,00	ORAR00456	ARP
279,30 x 5,70	OR5727930	G280	345,00 x 5,30	ORID34500	DIN/ISO
279,50 x 8,40	OR8427950	P280	345,00 x 7,00	ORIE34500	DIN/ISO
280,00 x 5,30	ORID28000	DIN/ISO	354,50 x 8,40	OR8435450	P355
280,00 x 7,00	ORIE28000	DIN/ISO	354,97 x 5,33	ORAR00383	ARP
284,50 x 8,40	OR8428450	P285	354,97 x 7,00	ORAR00457	ARP
289,30 x 5,70	OR5728930	G290	355,00 x 5,30	ORID35500	DIN/ISO
289,50 x 8,40	OR8428950	P290	355,00 x 7,00	ORIE35500	DIN/ISO
290,00 x 5,30	ORID29000	DIN/ISO	355,19 x 3,53	ORAR00280	ARP
290,00 x 7,00	ORIE29000	DIN/ISO	359,50 x 8,40	OR8435950	P360
291,47 x 5,33	ORAR00380	ARP	365,00 x 5,30	ORID36500	DIN/ISO
291,47 x 7,00	ORAR00452	ARP	365,00 x 7,00	ORIE36500	DIN/ISO
291,69 x 3,53	ORAR00277	ARP	367,67 x 7,00	ORAR00458	ARP
294,50 x 8,40	OR8429450	P295	374,50 x 8,40	OR8437400	P375
299,30 x 5,70	OR5729930	G300	375,00 x 5,30	ORID37500	DIN/ISO
299,50 x 8,40	OR8429950	P300	375,00 x 7,00	ORIE37500	DIN/ISO
300,00 x 5,30	ORID30000	DIN/ISO	380,37 x 5,33	ORAR00384	ARP
300,00 x 7,00	ORIE30000	DIN/ISO	380,37 x 7,00	ORAR00459	ARP



Table 40 O-Ring Ordering Information (Metric - Continued)

Dimensions d x W	Part No.	Standard	Dimensions d x W	Part No.	Standard
380,59 x 3,53	ORAR00281	ARP	545,00 x 7,00	ORIE54500	DIN/ISO
384,50 x 8,40	OR8438450	P385	557,66 x 5,33	ORAR00391	ARP
387,00 x 5,30	ORID38700	DIN/ISO	557,66 x 7,00	ORAR00471	ARP
387,00 x 7,00	ORIE38700	DIN/ISO	560,00 x 7,00	ORIE56000	DIN/ISO
393,07 x 7,00	ORAR00460	ARP	580,00 x 7,00	ORIE58000	DIN/ISO
399,50 x 8,40	OR8439950	P400	582,68 x 5,33	ORAR00392	ARP
400,00 x 5,30	ORID40000	DIN/ISO	582,68 x 7,00	ORAR00472	ARP
400,00 x 7,00	ORIE40000	DIN/ISO	600,00 x 7,00	ORIE60000	DIN/ISO
405,26 x 3,53	ORAR00282	ARP	608,08 x 5,33	ORAR00393	ARP
405,26 x 5,33	ORAR00385	ARP	608,08 x 7,00	ORAR00473	ARP
405,26 x 7,00	ORAR00461	ARP	615,00 x 7,00	ORIE61500	DIN/ISO
412,00 x 7,00	ORIE41200	DIN/ISO	630,00 x 7,00	ORIE63000	DIN/ISO
417,96 x 7,00	ORAR00462	ARP	633,48 x 5,33	ORAR00394	ARP
425,00 x 7,00	ORIE42500	DIN/ISO	633,48 x 7,00	ORAR00474	ARP
430,66 x 3,53	ORAR00283	ARP	650,00 x 7,00	ORIE65000	DIN/ISO
430,66 x 5,33	ORAR00386	ARP	658,88 x 5,33	ORAR00395	ARP
430,66 x 7,00	ORAR00463	ARP	658,88 x 7,00	ORAR00475	ARP
437,00 x 7,00	ORIE43700	DIN/ISO	670,00 x 7,00	ORIE67000	DIN/ISO
443,36 x 7,00	ORAR00464	ARP			
450,00 x 7,00	ORIE45000	DIN/ISO			
456,06 x 3,53	ORAR00284	ARP			
456,06 x 5,33	ORAR00387	ARP			
456,06 x 7,00	ORAR00465	ARP			
462,00 x 7,00	ORIE46200	DIN/ISO			
468,76 x 7,00	ORAR00466	ARP			
475,00 x 7,00	ORIE47500	DIN/ISO			
481,46 x 5,33	ORAR00388	ARP			
481,46 x 7,00	ORAR00467	ARP			
487,00 x 7,00	ORIE48700	DIN/ISO			
494,16 x 7,00	ORAR00468	ARP			
500,00 x 7,00	ORIE50000	DIN/ISO			
506,86 x 5,33	ORAR00389	ARP			
506,86 x 7,00	ORAR00469	ARP			
515,00 x 7,00	ORIE51500	DIN/ISO			
530,00 x 7,00	ORIE53000	DIN/ISO			
532,26 x 5,33	ORAR00390	ARP			
532,26 x 7,00	ORAR00470	ARP			

Ordering Example O-Ring 40 x 3

Dimensions: Inside Diameter = 40,0 mm
Cross Section = 3,0 mm

Compound: NBR70 (Nitrile Elastomer 70 Shore A)

The previously used part numbers can be used as an alternate reference. Ordering can also be made according to O-Ring dimensions and material.

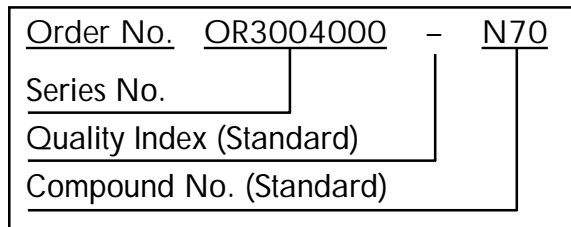



Table 41 Fluid and Chemical Compatibility

RATING GUIDE

- A - SATISFACTORY
- B - FAIR
- C - DOUBTFUL
- U - UNSATISFACTORY
- X - INSUFFICIENT DATA

Polymer	Compound No.	Temperature Range
Ethylene-Propylene	E75, E85	-60°C +150°C (-76°F +302°F)
Fluorocarbon	V70, V80, V90	-20°C +260°C (-4°F +500°F)
Neoprene	WC70	-40°C +120°C (-40°F +248°F)
Nitrile	N70, N80, N90	-54°C +135°C (-65°F +275°F)
Polyurethane	WU7T1, WU9T2	-40°C +100°C (-40°F +212°F)
Silicone	S70R	-75°C +260°C (-103°F +500°F)

MEDIUM	°F (-/+)	°C (-/+)	Ethylene Propylene	Fluoro-Carbon	Fluoro-Silicone	CR Neoprene	Nitrile	Poly-Acrylate	Poly-Urethane	Silicone (Static)
Acetaldehyde	-65/200	-55/95	A	U	U	C	U	U	U	A
Acetate Solvents	-65/200	-55/95	A	U	U	U	U	U	U	U
Acetic Acid	-65/200	-55/95	A	U	B	B	U	U	U	A
Acetic Acid Glacial	-65/200	-55/95	A	U	C	C	U	U	U	B
Acetic Acid Vapors	-65/200	-55/95	A	U	C	C	U	U	U	B
Acetic Anhydride	-65/200	-55/95	B	U	C	C	U	U	U	B
Acetone	-65/200	-55/95	A	U	U	U	U	U	U	U
Acetylene Gas	-40/200	-40/95	A	A	X	B	A	X	A	C
Acetylene Gas with Water or Liquid Hydrocarbon	-40/200	-40/95	A	A	X	B	A	X	A	C
Acetylene Tetrabromide	-20/200	-30/95	A	A	X	B	U	X	U	X
Acid Copper Plating Solution	-65/250	-55/120	A	A	C	A	B	U	U	C
Acid Spin Bath Rayon	-65/250	-55/120	A	U	U	B	B	U	U	U
Acid, Arsenic Solution	-40/160	-40/70	A	A	A	A	A	C	C	A
Acid, Benzoic Solution	-20/200	-30/95	U	A	B	U	U	U	U	U
Acid, Boric Solution	-40/200	-40/95	A	A	A	A	A	U	U	A
Acid, Butyric	-65/250	-55/120	B	B	X	U	U	U	X	X
Acid, Carbolic (Phenol)	-20/160	-30/70	B	A	A	C	U	U	C	U
Acid, Chloroacetic	-65/160	-55/70	B	U	U	U	U	U	U	U
Acid, Chlorosulfonic	No recommendation		U	C	U	U	U	U	U	U
Acid, Chromic Solution	-20/160	-30/70	C	A	C	U	U	U	U	C
Acid, Citric Solution	-40/200	-40/95	A	A	A	A	A	X	A	A
Acid, Fluosilicic	-65/120	-55/50	A	A	U	A	B	X	X	U
Acid, Formic	-65/200	-55/95	A	C	O	A	B	X	U	C
Acid, Hydrobromic	-40/120	-40/50	A	A	C	U	U	U	U	U
Acid, Hydrochloric or Muriatic	-20/160	-30/70	B	A	X	X	U	X	X	X
Acid, Hydrocyanic	-20/120	-30/50	A	A	B	B	B	U	X	C
Acid, Hydrofluosilicic	-20/120	-30/50	A	A	U	A	B	X	X	U
Acid, Hydroxy Acetic	-65/120	-55/50	A	U	B	B	C	C	U	U
Acid, Hypochlorous	-20/160	-30/70	B	A	X	U	U	U	X	X
Acid, Lactic	-40/160	-40/70	A	A	A	A	A	X	X	A
Acid, Maleic	-40/160	-40/70	A	U	X	U	B	X	X	U
Acid, Mine water	-20/180	-30/80	U	A	X	U	U	U	X	X



Table 41 Fluid and Chemical Compatibility (Continued)

MEDIUM	°F (-/+)	°C (-/+)	Ethylene Propylene	Fluoro- Carbon	Fluoro- Silicone	CR Neoprene	Nitrile	Poly- Acrylate	Poly- Urethane	Silicone (Static)
Acid, Napthenic	-20/120	-30/50	U	A	A	U	B	X	X	U
Acid, Nitric (under 10%)	-65/200	-55/95	A	A	B	A	U	U	U	C
Acid, Nitric, Concentrated	-20/120	-30/50	C	A	U	U	U	U	U	U
Acid, Nitric Fuming Red/White	-20/120	-30/50	U	B	U	U	U	U	U	U
Acid, Oleic	-40/160	-40/70	U	A	X	U	A	U	B	U
Acid, Oxalic	-65/160	-55/70	A	A	A	B	B	X	X	B
Acid, Palmitic	-40/160	-40/70	B	A	A	B	A	U	U	U
Acid, Phosphoric	-65/250	-55/120	A	A	C	B	B	B	U	C
Acid, Picric Solution	-40/160	-40/70	A	A	B	A	A	X	X	X
Acid, Propionic	-65/160	-55/70	A	U	X	B	A	U	U	A
Acid, Stearic	-40/250	-40/120	B	X	X	B	B	X	X	B
Acid, Sulfuric (50% & less)	-65/250	-55/120	A	A	C	B	C	U	B	U
Acid, Sulfuric, Concentrated	-65/120	-55/50	A	A	U	U	U	U	U	U
Acid, Sulphurous	-20/120	-30/50	B	A	X	U	U	U	U	U
Acid, Tannic	-40/200	-40/95	A	A	X	A	A	U	U	B
Acid, Tartaric	-40/200	-40/95	B	A	A	B	A	X	A	A
Acrolein	-40/120	-40/50	A	U	X	C	C	U	U	X
Acrylonitrile	No recommendation		X	X	U	U	U	U	U	U
Air	-40/200	-40/95	A	A	A	A	A	A	C	A
Alcohol, Methyl	-65/160	-55/70	A	U	A	A	A	U	U	A
Alcohol, IsoButyl	-65/160	-55/70	A	B	A	A	B	U	U	A
Alcohol, IsoPropyl	-65/160	-55/70	A	A	B	A	A	U	U	A
Alcohol, Octyl	-65/160	-55/70	A	A	B	B	B	U	U	B
Aldehyde Acetaldehyde	-65/120	-55/50	A	U	U	C	U	U	U	A
Alkyl Benzene	-20/120	-30/50	U	A	A	U	U	U	U	U
Alkylate, Light	-40/200	-40/95	U	A	A	U	A	A	A	U
Alkyl Arylsulphonic Acid	-65/120	-55/50	A	U	U	C	C	U	U	U
Allyl, Ketone	-65/120	-55/50	A	U	U	C	U	U	U	B
Allyl, Chloride	-20/120	-30/50	A	A	U	A	A	U	X	A
Alum, Solution	-40/160	-40/70	A	U	U	A	A	U	X	A
Aluminum Chloride, Solution	-40/160	-40/70	A	A	A	A	A	A	C	B
Aluminum Hydroxide, Solution	-40/160	-40/70	A	A	A	A	A	U	X	A
Aluminum Sulphate, Solution	-40/160	-40/70	A	A	A	A	A	U	X	A
Amines, Primary (such as Methyl, Ethyl, Propyl, Allyl)	-65/250	-55/120	A	U	U	U	U	U	U	C
Ammonia, Anhydrous	-40/120	-40/50	A	U	U	A	A	U	U	B
Ammonia, Anhydrous	-65/240	-55/115	A	U	U	A	C	U	U	C
Ammonia, Aqueous Solution	-65/200	-55/95	A	U	U	A	C	U	U	C
Ammonium Carbonate Solution	-40/160	-40/70	A	X	X	B	U	X	X	X
Ammonium Chloride Solution	-40/160	-40/70	A	X	X	A	A	X	X	X
Ammonium Hydroxide Solution	-40/160	-40/70	A	U	U	A	C	U	U	U
Ammonium Nitrate Solution	-40/160	-40/70	A	X	X	A	A	B	X	X
Ammonium Phosphate, Monobasic, Dibasi, Tribasic	-40/160	-40/70	A	X	X	A	A	X	X	A
Ammonium Sulfate Solution	-65/120	-55/50	A	U	X	A	A	U	X	X
Amyl Acetate	-65/200	-55/95	A	U	U	U	U	U	U	U
Amyl Alcohol	-65/200	-55/95	A	B	A	A	B	U	U	U
Amyl Chloride	-20/160	-30/70	U	A	B	U	X	U	X	U
Amyl Nitrate	-65/200	-55/95								
Anderol L-774 (MIL-L 7808 Type)	-65/275	-55/135	U	A	A	U	A	A	U	U
Anderol L-774 (MIL-L 7808 Type)	-20/400	-30/205	U	A	A	U	A	A	U	U
Aniline Liquid	-65/200	-55/95	A	U	U	U	U	U	U	U



Table 41 Fluid and Chemical Compatibility (Continued)

MEDIUM	°F (-/+)	°C (-/+)	Ethylene Propylene	Fluoro- Carbon	Fluoro- Silicone	CR Neoprene	Nitrile	Poly- Acrylate	Poly- Urethane	Silicone (Static)
Aromatic Fuels (up to 50% Aromatic)	-65/250	-55/120	U	A	A	U	A	B	B	U
Aromatic Hydrocarbons (100% Aromatic)	-20/300	-30/150	U	A	A	U	U	U	U	U
Arsenic Acid	-40/200	-40/95	A	A	A	A	A	C	C	A
Asphalt, Emulsion	-20/200	-30/95	U	A	B	B	B	B	B	U
Automatic Transmission Fluid	-40/250	-40/120	U	A	X	X	A	A	X	X
Automotive Gasoline	-65/250	-55/120	U	A	A	U	A	B	B	U
Automotive Gasoline	-60/250	-50/120	U	A	A	U	A	B	B	U
Aviation Gasoline (Ground Equip.)	-65/250	-55/120	U	A	A	U	A	U	B	U
Aviation Gasoline (Airborne Equip.)	-65/200	-55/95	U	U	A	U	A	U	B	U
B										
Barium Chloride Solution	-40/200	-40/95	A	A	A	A	A	U	A	A
Barium Hydroxide Solution	-40/200	-40/95	A	A	A	A	A	U	U	A
Barium Nitrate Solution	-40/200	-40/95	A	A	A	A	A	U	A	A
Barium Sulfide Solution	-40/200	-40/95	A	A	A	A	A	U	A	A
Beer	-65/250	-55/120	A	A	A	A	A	U	B	A
Beer, Wort	-65/250	-55/120	A	A	A	A	A	U	B	A
Beet Juice/Pulp	-40/200	-40/95	A	A	A	B	A	U	U	A
Beet Sugar Liquors	-40/200	-40/95	A	A	A	B	A	U	U	A
Benzaldehyde	-65/200	-55/95	A	U	U	U	U	U	U	B
Benzene (Benzol)	-20/300	-30/150	U	A	A	U	U	U	U	U
Benzene (Gasoline)	-65/250	-55/120	U	A	A	U	A	B	B	U
Benzoic Acid Solution	-20/160	-30/70	U	A	B	U	U	U	U	U
Benzol (Benzene)	-20/250	-30/120	U	A	A	U	U	U	U	U
Benzyl Chloride	-20/200	-30/95	U	A	A	U	U	U	U	U
Bichloride of Mercury Solution	-40/200	-40/95	A	A	A	A	U	U	A	A
Black Sulfate Liquor	-65/250	-55/120	A	A	X	B	B	U	U	X
Blast Furnace Gas	-65/250	-55/120	U	A	B	U	U	U	U	A
Bleaching Powder Solution	-65/200	-55/95	A	A	B	B	C	U	U	B
Boiler Feed Water	-65/250	-55/120	A	B	B	C	B	U	U	C
Borax Solutions	-65/200	-55/95	A	B	B	U	B	U	U	B
Bordeaux Mixtures	-40/160	-40/70	A	A	B	B	A	U	U	B
Boric Acid	-40/200	-40/95	A	A	A	A	A	U	A	A
Brake Fluids	-65/250	-55/120	A	U	U	B	U	U	U	U
Brine, Calcium Chloride Solution	-40/200	-40/95	A	A	A	A	A	U	B	A
Brine, Calcium Chloride Inhibited	-40/200	-40/95	A	A	A	A	A	U	B	A
Brine, Copper Chloride	-40/200	-40/95	A	A	A	B	A	A	A	A
Brine, Sea Water	-65/200	-55/95	A	A	A	B	A	U	B	A
Brine, Sodium Chloride, Solution	-40/200	-40/95	A	A	A	B	A	U	B	A
Bromine	-20/200	-30/95	U	A	B	U	U	U	U	U
Bunker "C" Fuel Oil	-65/250	-55/120	U	A	A	U	A	B	B	U
Butadiene	-20/250	-30/120	U	A	A	U	U	U	U	U
Butane	-40/200	-40/95	U	A	A	C	A	A	A	U
Buttermilk	-65/160	-55/70	A	A	A	A	A	U	A	A
Butyl Acetate	-65/250	-55/120	A	U	U	U	U	U	U	U
Butyl Alcohol	-65/250	-55/120	A	A	A	B	A	U	U	B
Butyl Amine (See Amines, primary)										
Butylene	-40/250	-40/120	U	A	A	C	A	A	B	U
Butyric Acid	-20/250	-30/120	U	A	B	C	B	U	U	U
Butyl Carbitol	-65/200	-55/95	A	C	U	C	U	U	X	U
Butyl Cellosolve	-65/200	-55/95	A	U	U	C	C	U	U	X
Butyl Phthalate	-65/250	-55/120	A	U	A	U	U	U	U	A



Table 41 Fluid and Chemical Compatibility (Continued)

MEDIUM	°F (-/+)	°C (-/+)	Ethylene Propylene	Fluoro- Carbon	Fluoro- Silicone	CR Neoprene	Nitrile	Poly- Acrylate	Poly- Urethane	Silicone (Static)
C										
Cabinol (Methanol)	-65/200	-55/95	A	U	A	A	A	U	U	A
Calcium Bisulfide Solution	-65/200	-55/95	A	B	C	B	B	C	C	C
Calcium Carbonate Slurry	-40/200	-40/95	A	A	A	A	A	U	U	A
Calcium Chloride Brine	-40/200	-40/95	A	A	A	A	A	U	B	A
Calcium Hydroxide Solution	-40/200	-40/95	A	A	A	A	A	U	B	A
Calcium Hypochlorite Solution	-65/250	-55/120	A	A	A	B	B	U	U	B
Calcium Phosphate Slurry	-40/200	-40/95	A	A	A	B	A	A	A	A
Calgon	-40/200	-40/95	A	A	A	A	A	U	U	A
Caliche Liquors	-40/200	-40/95	A	A	A	A	A	A	A	B
Cane Sugar Liquors & Juices	-40/200	-40/95	A	A	A	A	A	U	U	A
Carbolic Acid	-20/200	-30/95	B	A	A	U	U	U	C	U
Carbon Bisulfide	-20/200	-30/95	U	A	A	U	U	U	U	U
Carbon Dioxide Wet or Dry (Low Pressure)	-40/160	-40/70	B	B	B	B	A	X	A	B
Carbon Dioxide (High Pressure)	-65/200	-55/95	B	C	C	C	A	U	A	U
Carbon Monoxide	-40/160	-40/70	A	B	B	B	A	K	A	A
Carbon Tetrachloride Anhydrous	-20/250	-30/120	B	A	B	U	C	U	U	U
Carbonated Beverages	-65/250	-55/120	A	A	B	A	A	X	B	C
Carbonic Acid	-40/200	-40/95	A	A	A	A	A	X	A	A
Casein	-40/200	-40/95	B	A	A	A	A	X	X	A
Castor Oil	-40/200	-40/95	B	A	A	A	A	A	A	A
Caustic Soda	-65/250	-55/120	A	U	C	B	B	U	U	C
Cellulose	-40/200	-40/95	B	U	B	B	B	U	B	B
Chinawood Oil	-40/200	-40/95	U	A	A	B	A	X	C	U
Cellulubes	-65/250	-55/120	A	C	C	C	U	U	U	C
Chlorine, Anhydrous or Wet	-20/300	-30/150	U	C	U	U	U	U	X	U
Chlorine Dioxide	-20/400	-30/205	C	A	B	U	U	U	X	X
Chlorine Trifluoride	(No Compound available)									
Chlorinated Solvents (except MethylChloride)	-20/200	-30/95	U	A	A	U	U	U	X	U
Chlorinated Biphenyl	-20/160	-30/70	U	A	U	U	U	U	U	U
Chloroacetic Acid	-65/160	-55/70	A	U	B	U	U	U	U	U
Chloroacetaldehyde	-65/160	-55/70	A	U	C	U	U	U	U	U
Chlorobenzene, Mono, Di, Tri	-20/200	-30/95	U	A	A	U	U	U	U	U
Chlorobromomethane	-20/200	-30/95	B	A	B	U	U	U	U	U
Chloroform	-20/200	-30/95	U	A	U	U	U	U	U	U
Chloromethyl Ether	-65/160	-55/70	C	U	U	U	U	U	U	U
Chlorosulfonic Acid	-65/200	-55/95	C	U	U	U	U	U	U	U
Chlorox	-65/250	-55/120	B	A	A	B	B	U	U	X
Chromic Acid	-20/200	-30/95	C	A	C	U	U	U	U	C
Cider	-65/275	-55/135	A	B	A	B	A	U	U	B
Citric Acid Solution	-40/200	-40/95	A	A	A	A	A	X	X	A
Clay Slurry	-40/200	-40/95	A	B	C	A	A	X	A	C
Coal Tar	-65/200	-55/95	A	A	U	A	A	U	U	U
Cocoa Butter	-65/180	-55/80	U	A	A	B	A	X	B	U
Coca-Cola	-65/180	-55/80	A	B	A	B	A	U	B	A
Coconut, Fatty Acid	-40/200	-40/95	U	A	A	B	A	A	A	A
Coffee Extract	-65/250	-55/120	A	A	A	A	A	U	U	A
Coke Oven Gas	20/250	-5/120	U	A	B	U	U	U	U	B
Copper Ammonium Acetate	-65/200	-55/95	A	U	U	C	U	U	U	U
Copper Acetate Solution	-65/200	-55/95	A	U	U	C	U	U	U	U
Copper Chloride, Solution	-65/120	-55/50	A	A	A	B	A	U	B	A
Copper Plating Solution	-65/200	-55/95	A	A	C	A	B	U	U	C
Copper Sulfate (Blue Vitriol) Solution	-65/200	-55/95	A	A	A	A	A	U	U	A



Table 41 Fluid and Chemical Compatibility (Continued)

MEDIUM	°F (-/+)	°C (-/+)	Ethylene Propylene	Fluoro- Carbon	Fluoro- Silicone	CR Neoprene	Nitrile	Poly- Acrylate	Poly- Urethane	Silicone (Static)
Corn Oil	-40/200	-40/95	C	A	A	C	A	A	A	A
Corn Starch Slurry	-40/200	-40/95	A	A	A	B	A	U	B	B
Corn Syrup	-40/200	-40/95	A	A	A	B	A	U	B	A
Cottonseed Oil	-40/200	-40/95	C	A	A	C	A	A	A	A
Creosote	-20/200	-30/95	U	A	A	B	A	U	U	U
Creosols Cresylic Acid	-20/350	-30/175	A	A	B	U	U	U	A	U
Crontonaldehyde	-65/200	-55/95	A	U	U	U	U	U	U	U
Crude Oils	-65/250	-55/120	U	A	A	C	A	A	B	U
Cumene	-20/200	-30/95	U	A	U	U	U	U	U	U
Cyclohexylamine	-65/200	-55/95	A	U	U	U	U	U	U	U
Cuprous Ammonia Acetate Solution	-65/200	-55/95	A	U	U	U	U	U	U	U
Cyanic Acid Solution	-65/200	-55/95	A	U	U	U	U	U	U	U
Cyanic Compounds	-65/200	-55/95	A	U	U	U	U	U	U	U
Cyanogen	-65/200	-55/95	A	U	U	U	U	U	U	U
Cyclohexane	-65/250	-55/120	U	A	A	C	A	B	A	U
D										
DC 200, 510, 550, & 710 (Silicone Oils)	-20/300	-30/150	B	A	U	B	B	B	B	U
DDT Solutions (Toluene Solvent)	-20/300	-30/150	U	A	A	U	U	U	U	U
DDT Solutions (Kerosene Solvent)	-65/200	-55/95	U	A	A	C	A	B	B	U
Dead Oil	-20/300	-30/150	U	A	A	C	A	A	B	U
Diacetone Alcohol	-65/160	-55/70	A	U	U	B	U	U	U	U
Diamylamine	-65/200	-55/95	A	U	U	U	U	U	U	U
Dibutyl Cellosolve Adipate	-65/200	-55/95	A	U	U	U	U	U	U	U
Dibutyl Ether	-65/120	-55/50	C	U	C	U	U	C	U	U
Dibutyl Pthalate	-65/250	-55/120	A	C	C	U	U	U	C	U
Dichlorobenzene	-20/200	-30/95	U	A	A	U	U	U	U	U
Dichloroethane	-20/200	-30/95	U	A	C	U	U	U	U	U
Dichloro Pentane	-10/200	-25/95	U	A	C	U	U	U	U	U
Diesel Fuel	-65/250	-55/120	U	A	A	U	A	B	C	U
Diethanolamine	-65/160	-55/70	A	U	U	U	U	U	U	U
Diethyl Aniline	-65/160	-55/70	A	U	U	U	U	U	U	U
Diethyl Benzene	-20/200	-30/95	U	A	A	U	U	U	U	U
Diethyl Carbonate	-20/200	-30/95	U	A	B	U	U	U	U	U
Diethyl Formaldehyde	-65/200	-55/95	A	U	U	U	U	U	U	U
Diethyl Hydrazine	-65/160	-55/70	A	U	U	C	C	U	U	U
Diethyl Maleate	-65/160	-55/70	A	U	U	C	C	U	U	U
Diethyl Sulfate	-65/160	-55/70	A	U	C	A	U	U	U	A
Diethylene Glycol	-40/200	-40/95	A	A	A	A	A	U	U	B
Diethylene Triamine	-65/200	-55/95	A	U	U	U	U	U	U	U
Di-Isobutyl Ketone	-65/200	-55/95	A	U	U	U	U	U	U	U
Di-Isobutylene	-40/200	-40/95	U	A	C	U	A	U	U	U
Di-Isopropyl Benzene	-20/200	-30/95	U	A	A	U	U	U	U	U
Dimethyl Aniline	-65/160	-55/70	A	U	U	U	U	U	U	U
Dimethyl Phthalate	-65/200	-55/95	B	B	B	U	U	U	U	X
Diocetyl Amine	-65/120	-55/50	A	U	U	U	U	U	U	U
Diocetyl Phthalate	-65/200	-55/95	A	B	U	U	U	U	U	X
Dioxane	-65/160	-55/70	A	U	U	U	U	U	U	U
Dipentene	-65/200	-55/95	U	A	A	U	A	U	U	U
Diphenyl	-20/300	-30/150	U	A	B	U	U	U	U	U



Table 41 Fluid and Chemical Compatibility (Continued)

MEDIUM	°F (-/+)	°C (-/+)	Ethylene Propylene	Fluoro- Carbon	Fluoro- Silicone	CR Neoprene	Nitrile	Poly- Acrylate	Poly- Urethane	Silicone (Static)
Diphenyl, Chlorinated	-20/300	-30/150	U	A	B	U	U	U	U	U
Divinyl Benzene	-20/120	-30/50	U	A	B	U	U	U	U	U
DMT (Dimethyl Terephthalate)	-65/200	-55/95	A	A	B	U	U	U	U	U
DNCB (Dinitrochlorobenzene)	-20/120	-30/50	U	A	B	U	U	U	U	U
Dowanol	-65/120	-55/50	A	U	U	U	B	U	U	U
Dowtherm A	-20/300	-30/150	U	A	B	U	U	U	U	U
Dowtherm E	-20/300	-30/150	U	A	B	U	U	U	U	U
E										
Embalming Fluid	-40/160	-40/70	X	X	X	X	A	X	X	X
Esso Turbo Oil	-65/250	-55/120	U	A	A	U	A	B	U	U
Esso Turbo Oil	-20/400	-30/205	U	A	A	U	U	U	U	U
Ethane	-65/120	-55/50	U	A	A	U	A	A	B	U
Ethanolamine	-65/120	-55/50	A	U	U	U	U	U	U	U
Ethanolamine, Mono, Di, Tri	-65/120	-55/50	A	U	U	U	U	U	U	U
Ether	-65/160	-55/70	C	U	U	U	U	U	U	U
Ethyl Acetate	-65/200	-55/95	A	U	U	U	U	U	U	U
Ethyl Alcohol	-65/200	-55/95	A	C	B	B	A	U	U	B
Ethyl Amine (See Amines primary)										
Ethyl Bromide	-20/200	-30/95	U	A	A	U	B	U	U	U
Ethyl Cellulose	-40/200	-40/95	B	U	U	B	B	U	B	B
Ethyl Chloride	-20/200	-30/95	C	A	A	U	A	C	B	U
Ethyl Dichloride	-20/200	-30/95	U	A	A	U	U	U	U	U
Ethyl Ether (See Ether)										
Ethyl Mercaptan	-65/200	-55/95	A	B	X	C	U	X	X	U
Ethyl Pyridine	-65/200	-55/95	A	U	U	U	U	U	U	U
Ethyl Sulfate (Diethyl Sulfate)	-65/200	-55/95	A							
Ethylene	-65/200	-55/95	U	A	A	C	A	B	B	U
Ethylene Bromide	-20/200	-30/95	C	A	C	U	U	U	U	U
Ethylene Chloride	-20/120	-30/50	U	A	B	U	U	U	U	U
Ethylene Diamine	-65/120	-55/50	A	U	U	U	U	U	U	U
Ethylene Dibromide	-20/120	-30/50	U	A	C	U	U	U	U	U
Ethylene Dichloride	-20/120	-30/50	U	A	C	U	U	U	U	U
Ethylene Glycol	-40/200	-40/95	A	A	A	B	A	A	B	C
Ethylene Oxide	-65/120	-55/50	A	U	U	U	U	U	U	U
F										
Fatty Acids	-40/250	-40/120	U	A	A	B	A	A	B	C
Ferric Chloride Solution	-40/160	-40/70	A	A	A	B	A	X	A	B
Ferric Sulphate Solution	-40/160	-40/70	A	A	A	A	A	X	A	B
Ferrous Sulfate (Green Cooperas) Solution	-40/160	-40/70	A	A	A	A	A	X	A	B
Film Dope	-65/160	-55/70	A							
Fish Oil	-40/250	-40/120	U	A	A	B	A	A	B	U
Fluoroboric Acid	-40/120	-40/50	A	A	A	A	A	X	X	A
Fluorine (No compound available)										
Fluorosilicic	-40/120	-40/50	A	A	A	A	A	X	X	A
Formaldehyde (Formalin)	-65/120	-55/50	A	U	U	U	C	U	U	C
Formic Acid	-65/120	-55/50	A	U	C	B	C	X	X	C
Freons	-50/250	-45/120								

Consult B+S Engineering for specific compounds



Table 41 Fluid and Chemical Compatibility (Continued)

MEDIUM	°F (-/+)	°C (-/+)	Ethylene Propylene	Fluoro- Carbon	Fluoro- Silicone	CR Neoprene	Nitrile	Poly- Acrylate	Poly- Urethane	Silicone (Static)
Fruit Juices	-65/250	-55/120	A	A	A	A	A	X	X	A
Fumaric Acid	-65/160	-55/70	B	A	A	B	A	X	X	A
Furfural	-65/160	-55/70	A	U	U	U	U	U	C	U
Fuel Oils	-65/250	-55/120	U	A	A	U	A	A	A	U
G										
Gallic Acid	-20/120	-30/50	B	A	B	B	B	U	U	X
Gas Oil	-65/250	-55/120	U	A	A	U	A	U	B	U
Gasoline, Aromatic	-65/250	-55/120	U	A	A	U	A	U	A	U
Gasoline, Automotive	-65/250	-55/120	U	A	A	U	A	U	B	U
Gasoline, Ethyl and Regular	-65/250	-55/120	U	A	A	U	A	U	B	U
Gasoline, 100 Octane	-65/250	-55/120	U	A	A	U	A	U	B	U
Gasoline, 130 Octane	-65/250	-55/120	U	A	A	U	A	U	B	U
Gasoline, Refined	-65/250	-55/120	U	A	A	U	A	U	B	U
Gasoline, Sour	-65/250	-55/120	U	A	A	U	A	U	B	U
Gasoline, with Mercaptan	-65/250	-55/120	U	A	A	U	A	U	B	U
Gelatin	-40/200	-40/95	A	A	A	A	A	U	U	A
Glacial Acetic Acid	-65/120	-55/50	A	U	U	U	C	U	U	B
Glaubers Salt	-20/160	-30/70	B	A	A	B	U	U	X	X
Glucose	-40/200	-40/95	A	A	A	A	A	X	U	A
Glue	-40/160	-40/70	A	A	A	A	A	A	A	A
Glue Sizing	-40/160	-40/70	A	A	A	A	A	A	A	A
Glycerin (Glycerol)	-40/250	-40/120	A	A	A	A	A	U	U	A
Glycerol	-40/250	-40/120	A	A	A	A	A	U	U	A
Glycol, Diethylene	-40/250	-40/120	A	A	A	A	A	U	U	A
Glycol, Ethylene	-40/250	-40/120	A	A	A	A	A	U	B	A
Glycol, Propylene	-40/250	-40/120	A	A	A	A	A	U	U	A
Grain Mash	-65/250	-55/120	A	A	A	A	A	U	U	A
Grape Juice	-65/250	-55/120	A	A	A	A	A	U	U	A
Green Sulfate Liquor	-65/200	-55/95	A	A	B	B	B	U	U	X
H										
HEF-3	-20/120	-30/50	U	A	B	U	B	U	U	U
Helium Gas	-40/200	-40/95	A	A	A	A	A	A	A	A
Heptane	-65/250	-55/120	U	A	A	B	A	A	B	U
Hexamine	-20/250	-30/120	A	U	U	U	U	U	U	U
Hexane	-65/250	-55/120	U	A	A	B	A	A	B	U
Hexachloro Acetone	-65/200	-55/95	A	U	U	U	U	U	U	U
Hexone	-65/200	-55/95	A	U	U	B	U	U	U	B
Hexyl Alcohol	-65/200	-55/95	A	A	B	B	A	U	U	B
Hought-O-Safe (1000 & 1100 Series)	-65/250	-55/120	A	A	B	U	U	U	X	C
Hought-O-Safe (620)	-40/250	-40/120	A	B	B	B	A	U	U	B
Hydrazine Anhydrous	-65/200	-55/95	A	U	U	B	B	X	U	B
Hydraulic Oils, Petroleum Base, -40	-40/250	-40/120	U	A	A	C	A	A	A	U
	-65/250	-55/120								
Hydrobromic Acid	-65/200	-55/95	A	A	C	U	U	U	U	U
Hydrocarbons, Light	-40/250	-40/120	U	A	A	U	A	A	A	U
Hydrochloric Acid (Muriatic Acid) 37%	-20/160	-30/70	B	A	U	U	U	U	U	U
Hydrocyanic Acid	-65/120	-55/50	A	A	B	B	B	U	X	C
Hydrofluosilicic Acid	-65/120	-55/50	A	A	U	B	B	X	X	U



Table 41 Fluid and Chemical Compatibility (Continued)

MEDIUM	°F (-/+)	°C (-/+)	Ethylene Propylene	Fluoro- Carbon	Fluoro- Silicone	CR Neoprene	Nitrile	Poly- Acrylate	Poly- Urethane	Silicone (Static)
Hydrofluoric Acid	-20/120	-30/50	U	B	U	U	U	U	U	U
Hydrogen, Gas	-40/200	-40/95	A	A	C	A	A	B	A	C
Hydrogen, Bromide, Anhydrous	-20/120	-30/50	A	A	U	B	C	U	U	U
Hydrogen Chloride Gas	-65/200	-55/95	A	A	C	B	U	X	X	U
Hydrogen Fluoride	-20/120	-30/50	B	A	U	U	U	U	U	U
Hydrogen Peroxide (Less than 90% Active)	-20/160	-30/70	U	B	U	U	U	U	U	B
Hydrogen Peroxide (90% Active)	-40/160	-40/70	U	A	U	U	U	U	U	B
Hydrogen Sulfide	-65/250	-55/120	A	U	U	B	U	U	X	U
Hydrosulfite	-40/120	-40/50					A			
Hydroxy Acetic Acid	-65/200	-55/95	A	U	U	U	U	U	U	B
Hydrochlorous Acid	-40/120	-40/50	A	A	A	B	A	U	U	U
Hypoid Lubes, Gear Oils	-10/300	-25/150	U	U	U	U	U	A	U	U
I										
Ink										
Insecticides	-20/200	-30/95	X	A	X	X	X	X	X	X
Iodine	-65/160	-55/70	A	A	A	U	B	X	X	X
Iodoform	-65/120	-55/50	A	X	X	X	X	X	X	X
Iron Pyritic Acid	-65/120	-55/50	A	X	X	X	X	X	X	X
Iron Sulfate Solution	-40/200	-40/95	A	A	A	A	A	A	A	B
Iso-Butane	-65/250	-55/120	U	A	A	U	A	A	A	U
Iso-Butyl Alcohol	-65/160	-55/70	A	A	B	A	B	U	U	A
Iso-Butyl Methyl Ketone	-65/200	-55/95	A	U	U	U	U	U	U	U
Iso-Butylene	-40/250	-40/120	U	A	A	U	A	U	U	U
Iso-Butyraldehyde	-65/160	-55/70	A	U	U	U	U	U	U	U
Iso-Cyanate	-65/120	-55/50	A	X	X	X	X	X	X	X
Iso-Octane	-65/250	-55/120	U	A	A	U	A	A	B	U
Iso-Pentane	-65/250	-55/120	U	A	A	U	A	A	B	U
Iso-Propyl-Acetate	-65/160	-55/70	A	U	U	U	U	U	U	U
Iso-Propyl-Alcohol	-65/160	-55/70	A	A	A	A	A	U	U	A
Iso-Propyl-Benzene	-20/200	-30/95	U	A	A	U	U	U	U	U
Iso-Propyl-Chloride	-20/160	-30/70	U	A	B	U	U	U	U	U
Iso-Propyl-Ether	-65/200	-55/95	C	U	U	U	U	U	U	U
J										
Jet Fuel (JP 4 & JP 5) (7 & 8) (Ground Equip.)	-65/250	-55/120	U	A	A	U	A	A	B	U
Jet Fuel (JP 4 & JP 5) (7 & 8) (Airborne Equip.)	-65/200	-55/95	U	A	A	U	A	U	B	U
K										
Kerosene	-65/250	-55/120	U	A	A	U	A	A	B	U
Ketchup	-40/200	-40/95	A	A	A	A	A	U	B	A
Ketones	-65/200	-55/95	A	U	U	U	U	U	U	U
L										
Lacquer (with Ketone Solvent)	-65/160	-55/70	A	U	U	U	U	U	U	U
Lactic Acid	-40/200	-40/95	U	A	B	U	A	U	U	B
Lard	-40/200	-40/95	B	A	A	B	A	A	A	B



Table 41 Fluid and Chemical Compatibility (Continued)

MEDIUM	°F (-/+)	°C (-/+)	Ethylene Propylene	Fluoro- Carbon	Fluoro- Silicone	CR Neoprene	Nitrile	Poly- Acrylate	Poly- Urethane	Silicone (Static)
Latex	-40/160	-40/70	A	A	A	A	A	U	U	A
Lead Acetate Salt Solution	-65/200	-55/95	A	U	U	U	C	U	U	U
Lead Nitrate Solution	-40/200	-40/95	A	X	A	A	A	X	X	B
Lime Water (Milk of Lime)	-40/160	-40/70	A	A	A	B	A	U	X	B
Lindol	-65/250	-55/120	A	U	C	U	U	U	U	C
Linseed Oil	-40/200	-40/95	C	A	A	C	A	A	B	A
Liquified Petroleum Gases, LPG	-65/250	-55/120	U	A	A	U	A	C	A	C
Lithium Bromide Brine	-40/160	-40/70	A	A	A	A	A	U	U	A
Lithium Chloride	-40/160	-40/70	A	A	A	A	A	U	U	A
Lithium Hydroxide	-65/160	-55/70	A	C	U	U	U	U	U	U
Lube Oil (SAE) 10, 20, 30, etc.	-40/250	-40/120	U	A	A	U	A	A	A	U
Lye (See Sodium Hydroxide)										
M										
Magnesium Acetate Solution	-65/120	-55/50	A	U	U	U	U	U	U	U
Magnesium Chloride Solution	-40/120	-40/50	A	A	A	A	A	X	A	A
Maganese Chloride	-40/160	-40/70	A	A	A	A	A	U	B	A
Magnesium Hydroxide Solution	-65/120	-55/50	A	A	X	B	B	U	U	X
Magnesium Sulfate (Epson Salts)	-40/120	-40/50	A	A	A	A	A	U	X	A
Maleic Acid	-65/120	-55/50	A	U	X	U	U	U	U	U
Malt Beverage	-65/250	-55/120	A	A	A	A	A	U	B	A
Marsh Gas	-65/250	-55/120	U	A	A	U	A	A	B	U
Mayonaise	-65/250	-55/120	U	U	U	U	A	X	U	A
Melamine Resins	-65/120	-55/50	A	X	X	X	X	U	U	X
Mercaptans	-65/160	-55/70	A	U	U	U	U	U	U	U
Mercuric Chloride Solution	-40/160	-40/70	A	A	A	A	A	X	X	A
Mercury	-40/120	-40/50	A	A	A	A	A	X	X	A
Mesityl Oxide	-65/120	-55/50	A	U	U	U	U	U	U	U
Methanol Std. Fluorocarbon not satisfactory	-65/160	-55/70	A	A	A	A	A	U	U	A
Methyl Acetate	-65/160	-55/70	A	U	U	U	U	U	U	U
Methyl Acrylate	-65/160	-55/70	A	U	U	B	U	U	U	U
Methyl Bromide	-20/160	-30/70	U	A	A	U	B	C	X	X
Methyl Chloride	-40/160	-40/70	U	U	U	B	U	U	U	U
Methyl Cellosolve	-65/200	-55/95	A	U	U	U	U	U	U	U
Methyl Cyclopentane	-20/250	-30/120	U	A	B	U	U	U	U	U
Methyl Ethyl Ketone	-65/120	-55/50	A	U	U	U	U	U	U	U
Methyl Formate	-65/120	-55/50	A	U	U	U	U	U	U	U
Methyl Iso-Butyl Ketone	-65/120	-55/50	A	U	U	U	U	U	U	U
Methyl Methacrylate	-65/160	-55/70	U	U	U	U	U	U	U	U
Methylene Chloride	-20/160	-30/70	U	B	C	U	U	U	U	U
Methylene Dichloride	-20/160	-30/70	U	A	B	U	U	U	U	U
Milk	-65/250	-55/120	A	A	A	A	A	U	B	A
Mineral Spirits	-65/250	-55/120	U	A	A	C	A	A	B	U
Molasses	-40/200	-40/95	A	A	A	A	A	U	B	A
Monochloroacetic Acid	-65/200	-55/95	A	U	U	U	U	U	U	B
Monochlorobenzene	-20/200	-30/95	U	A	A	U	U	U	U	U
Monoethanolamine (MEA)	-65/200	-55/95	A	U	U	U	U	U	U	U
Mononitrochlorobenzene	-20/160	-30/70	U	A	A	U	U	U	U	U
Muriatic Acid (HCL)	-20/160	-30/70	B	A	X	X	U	U	U	U
Mustard	-40/160	-40/70	A	A	A	A	A	X	X	A



Table 41 Fluid and Chemical Compatibility (Continued)

MEDIUM	°F (-/+)	°C (-/+)	Ethylene Propylene	Fluoro- Carbon	Fluoro- Silicone	CR Neoprene	Nitrile	Poly- Acrylate	Poly- Urethane	Silicone (Static)
N										
Naptha	-65/250	-55/120	U	A	A	U	A	A	A	U
Naptha Sour	-65/250	-55/120	U	A	A	U	A	A	A	U
Napthalene	-20/160	-30/70	U	A	A	U	U	X	B	U
Naphthenic Acid	-20/160	-30/70	U	A	A	X	A	X	X	X
Natural Gas	-65/250	-55/120	U	A	A	B	A	A	B	U
Neats Foot Oil	-40/250	-40/120	B	A	A	U	A	A	A	B
Nickel Chloride	-40/160	-40/70	A	A	A	B	A	C	C	A
Nickel Sulfate	-40/160	-40/70	A	A	A	A	A	U	C	A
Nitrating Acids	-65/120	-55/50	A	U	U	U	U	U	U	U
Nitric Acid (Concentrated)	-20/120	-30/50	B	A	U	U	U	U	U	U
Nitric Acid (10-50%) RFNA, IRFNA	-65/120	-55/50	A	A	U	U	U	U	U	U
Nitric Acid Fuming	-20/120	-30/50	U	B	U	U	U	U	U	U
Nitrobenzene	-20/120	-30/50	U	A	B	A	U	U	U	U
Nitro Methane	-65/120	-55/50	A	U	U	U	U	U	U	U
Nitrogen Gas	-65/200	-55/95	A	A	A	A	A	A	A	A
Nitrous Oxide			A	A	X	X	A	X	X	A
Nitrogen Tetroxide, Very limited exposure	-65/70	-55/20	B	U	U	U	U	U	U	U
O										
Oil, Air Force Hydraulic, MIL-H-5606B	-65/275	-55/135	U	A	A	U	A	A	B	U
Oil, Asphalt Base	-20/300	-30/150	U	A	B	U	B	B	B	U
Oil, Bunker C Fuel Oil	-65/250	-55/120	U	A	A	U	A	A	A	U
Oil, Caster	-40/250	-40/120	B	A	A	A	A	A	A	A
Oil, Chinawood	-40/250	-40/120	U	A	A	B	A	X	C	U
Oil, Coconut	-40/250	-40/120	U	A	A	A	A	A	A	B
Oil, Corn	-40/250	-40/120	C	A	A	C	A	A	A	A
Oil, Cottonseed	-40/250	-40/120	C	A	A	C	A	A	A	A
Oil, Crude (Asphalt Base)	-20/250	-30/120	U	A	B	U	B	B	B	U
Oil, Crude (Corrosive)	-65/250	-55/120	U	A	A	U	A	B	B	U
Oil, Crude (Parafin Base)	-65/250	-55/120	U	A	A	U	A	B	B	U
Oil, Crude (Sweet)	-40/250	-40/120	U	A	A	U	A	B	B	U
Oil, Cutting Soluble	-40/250	-40/120	U	A	A	C	A	A	A	U
Oil, Diesel	-65/250	-55/120	U	A	A	U	A	A	A	U
Oil, Domestic Fuel	-65/250	-55/120	U	A	A	U	A	A	A	U
Oil, Fuel	-65/250	-55/120	U	A	A	U	A	A	A	U
Oil, Fuel & Gas	-65/250	-55/120	U	A	A	U	A	A	A	U
Oil, #6 Fuel Oil	-65/250	-55/120	U	A	A	U	A	A	A	U
Oil, Hydraulic	-40/250	-40/120	U	A	A	U	A	U	A	U
	-65/250	-55/120	U	U	A	U	A	U	A	U
Oil, Hydraulic	-65/275	-55/135	U	A	A	U	A	U	A	U
Oil, Linseed	-40/250	-40/120	U	A	A	C	A	A	B	U
Oil, Lubricating	-40/250	-40/120	U	A	A	U	A	A	A	U
Oil, Mineral	-40/250	-40/120	U	A	A	C	A	A	A	U
Oil, Nut	-40/250	-40/120	U	A	A	U	A	A	A	U
Oil, Olive	-40/250	-40/120	U	A	A	U	A	A	A	U
Oil, Palm	-40/200	-40/95	U	A	A	U	A	A	A	U
Oil, Parafin Base (Petroleum)	-40/250	-40/120	U	A	A	U	A	A	A	U
Oil, Peanut	-40/200	-40/95	U	A	A	U	A	A	A	U
Oil, Petroleum (Crude)	-40/250	-40/120	U	A	A	U	A	A	A	U



Table 41 Fluid and Chemical Compatibility (Continued)

MEDIUM	°F (-/+)	°C (-/+)	Ethylene Propylene	Fluoro- Carbon	Fluoro- Silicone	CR Neoprene	Nitrile	Poly- Acrylate	Poly- Urethane	Silicone (Static)
Oil, Pine	-40/250	-40/120	U	A	A	U	A	A	A	U
Oil, Quenching	-40/250	-40/120	U	A	A	U	A	A	A	U
Oil, Rapeseed	-40/250	-40/120	U	A	A	U	A	A	A	U
Oil, Silicone	-20/375	-30/190	A	A	A	A	A	X	X	U
Oil, Soya Bean	-40/250	-40/120	U	A	A	A	A	A	A	U
Oil, Tall	-40/250	-40/120	U	A	A	A	A	A	A	A
Oil, Transformer	-20/300	-30/150	U	A	A	X	A	X	X	A
Oil, Vegetable Types (Food Service)	-40/250	-40/120	U	A	A	U	A	A	A	U
Oil, Vegetable Types (Non-Food Service)	-40/250	-40/120	U	A	A	U	A	A	A	U
Oil, and Freon 11 & 12 & 114	-40/200	-40/95	U	U	U	A	A	U	U	U
Oil, and Freon 22 (Low Aniline Oil)	-40/200	-40/95	U	U	U	A	U	U	U	U
Oil, and Freon 22 (High Aniline Oil)	-40/200	-40/95	U	U	U	A	U	U	U	U
Olefin, Crude	-40/250	-40/120	U	A	A	U	A	A	A	U
Oleic Acid	-40/160	-40/70	U	A	X	U	A	X	X	U
Oleum	-20/160	-30/70	U	A	U	U	U	U	U	U
Oleum Spirits	-65/160	-55/70	U	A	B	U	B	X	C	U
Oronite 8200 & 8515	-20/400	-30/205	U	A	A	A	U	X	A	U
Orthodichlorobenzene	-20/200	-30/95	U	A	B	U	U	U	U	U
OS 45 and OS-45-1	-20/400	-30/205	U	A	B	A	U	U	U	U
OS 45 and OS-45-1	-40/250	-40/120	U	A	B	A	U	U	U	U
Oxalic Acid	-65/250	-55/120	A	A	A	B	B	X	X	B
Oxygen, Gaseous, Low Pressure	-40/200	-40/95	A	A	A	A	B	B	A	A
Oxygen, Liquid	(No Compound Available)		U	U	U	U	U	U	U	U
Ozone (High Concentration Static)	-80/400	-60/205	A	A	A	B	C	A	A	A
Ozone (High Concentration Dynamic)	-20/400	-30/205	A	A	U	B	C	A	A	U
P										
Palmitic Acid	-40/160	-40/70	B	A	A	B	A	X	A	X
Palm Oil	-40/250	-40/120	U	A	A	U	A	A	A	U
Parafin (Molten)	-40/250	-40/120	U	A	A	B	A	A	A	B
Pectin Liquor	-40/200	-40/95	U	A	A	C	A	A	A	A
Penicillin Liquid	-80/200	-60/95	X	X	X	X	X	X	X	A
Pentane	-65/250	-55/120	U	A	A	U	A	A	U	U
Pentachloro Phenol	-20/250	-30/120	B	A	B	B	C	X	U	X
Pentasol	-65/160	-55/70	A	B	A	A	B	U	U	U
Perchloroethylene	-20/200	-30/95	U	A	B	U	U	U	U	B
Peroxide of Hydrogen	See Hydrogen Peroxide									
Petroleum Ether (Ligraine)	-65/160	-55/70	U	A	A	U	A	A	B	U
Petroleum Ether, Liquified (UL Approved)	-65/200	-55/95	U	A	A	U	A	B	A	U
Petroleum Oils	-40/250	-40/120	U	A	A	U	A	B	A	U
Phenol	-65/200	-55/95	A	A	B	U	U	U	U	U
Phenylacetic Acid 75%	-65/200	-55/95	A	U	U	U	U	U	U	U
Phenylcellulosolve	-65/200	-55/95	A	A	A	A	U	U	U	A
Phosphoric Acid 45%	-65/200	-55/95	A	A	A	B	B	C	U	B
Phthalic Anhydride	-65/20	-55/95	A	X	X	X	X	X	X	X
Picoline, Alpha	-65/250	-55/120	A	U	X	X	X	X	X	X
Picric Acid, Aqueous Solution	-65/200	-55/95	A	A	B	A	B	X	B	U
Polyvinyl Acetates	-65/20	-55/95	A	U	X	B	X	X	X	X
Poly Glycols	-40/250	-40/120	A	A	A	A	A	U	U	A
Potassium Bicarbonate	-40/200	-40/95	A	A	A	A	A	U	U	A
Potassium Bromide	-40/200	-40/95	A	A	A	A	A	U	U	A
Potassium Carbonate	-40/200	-40/95	A	A	A	A	A	U	U	A



Table 41 Fluid and Chemical Compatibility (Continued)

MEDIUM	°F (-/+)	°C (-/+)	Ethylene Propylene	Fluoro- Carbon	Fluoro- Silicone	CR Neoprene	Nitrile	Poly- Acrylate	Poly- Urethane	Silicone (Static)
Potassium Chloride	-40/200	-40/95	A	A	A	A	A	A	A	A
Potassium Cyanide	-40/200	-40/95	A	A	A	A	A	A	A	A
Potassium Hydroxide	-65/200	-55/95	A	B	C	A	B	U	U	C
Potassium Perfluoroacetate	-65/200	-55/95	A	U	U	B	B	X	X	X
Potassium Permanganate	-65/200	-55/95	A	A	X	X	X	X	X	X
Potassium Prospante, Di, Tri	-40/200	-40/95	A	A	A	A	A	U	U	A
Potassium Silicate	-40/160	-40/70	A	A	A	A	A	A	A	A
Potassium Sulfate	-40/160	-40/70	A	A	A	A	A	U	A	A
Power Steering Fluid	-40/250	-40/120	X	X	X	X	A	X	X	X
Prestone	-40/250	-40/120	A	A	A	A	A	U	U	A
Producer Gas	-65/250	-55/120	U	A	A	U	A	U	U	A
Propane	-65/250	-55/120	U	A	A	U	A	U	U	A
Propanol	-65/200	-55/95	A	U	A	A	A	U	U	A
Propanol	-40/200	-40/95	A	A	A	A	A	U	U	A
Propionic Acid	-65/200	-55/95	A	U	X	B	A	U	U	A
Propion Aldehyde	-65/200	-55/95	A	U	U	U	U	U	U	U
Porpylene	-40/250	-40/120	U	A	A	U	A	U	U	U
Propylene Glycol	-40/250	-40/120	A	A	A	A	A	U	U	A
Propylene Dichloride	-20/300	-30/150	U	A	B	U	U	U	U	U
Propylene Oxide	-65/120	-55/50	B	U	U	U	U	U	U	U
Propyl Nitrate	-65/160	-55/70	B	U	U	U	U	U	U	U
Pulp Stock	-40/200	-40/95	A	A	A	A	A	U	U	A
Pyridine	-65/160	-55/70	A	U	U	U	U	U	U	U
R										
Rapeseed Oil	-40/250	-40/120	U	A	A	B	A	U	U	U
Rosin Paper Mill	-40/200	-40/95	A	A	A	A	A	U	U	A
Rosins	-40/200	-40/95	A	A	A	A	A	U	U	A
S										
Sal Ammoniac	-40/160	-40/70	A	A	A	A	A	A	A	B
Salicylic Acid	-65/200	-55/95	A	A	A	X	B	X	X	X
Salt Solution	-40/200	-40/95	A	A	A	A	A	U	U	A
Sea Water	200	95	A	A	A	B	A	U	U	A
Sewage	200	95	A	A	A	A	A	U	U	A
Shellac	-65/200	-55/95	A	X	X	X	X	X	X	X
Silver Cyanide Solution	-65/120	-55/50	U	A	A	A	U	U	U	U
Silicate Esters	-20/400	-30/205	U	A	A	B	B	U	U	U
Silicone Oils & Greases	See Oil	Silicone								
Silver Nitrate Solution	-40/120	-40/50	A	A	A	A	B	A	A	A
Silver Salts	-40/200	-40/95	A	A	A	A	A	U	U	A
Skydrol (7000 and 500)	-65/250	-55/120	A	U	U	U	U	U	U	U
Sludge, Acid	-65/200	-55/95	A	X	X	X	X	X	X	X
Soap, Liquor	-40/200	-40/95	A	A	A	A	A	U	U	A
Soap, Solution	-40/200	-40/95	A	A	A	A	A	U	U	A
Soda Ash (Sodium Carbonate)	-40/160	-40/70	A	A	A	A	A	U	U	A
Soda, Caustic	See Sodium Hydroxide									
Sodium Acetate Solution	-65/200	-55/95	A	U	U	B	B	U	U	X
Sodium Bicarbonate Solution	-40/200	-40/95	A	A	A	A	A	U	U	A
Sodium Bisulfate Solution	-40/200	-40/95	A	A	A	A	A	U	A	A



Table 41 Fluid and Chemical Compatibility (Continued)

MEDIUM	°F (-/+)	°C (-/+)	Ethylene Propylene	Fluoro- Carbon	Fluoro- Silicone	CR Neoprene	Nitrile	Poly- Acrylate	Poly- Urethane	Silicone (Static)
Sodium Bisulfite Solution	-40/200	-40/95	A	A	A	A	A	U	A	A
Sodium Carbonate Solution	-40/200	-40/95	A	A	A	A	A	X	X	A
Sodium Chloride Solution	-40/200	-40/95	A	A	X	A	A	X	X	X
Sodium Cyanide Solution	-65/120	-55/50	A	X	X	A	A	X	X	A
Sodium Hydroxide Solution	-65/250	-55/120	A	A	C	A	B	U	U	C
Sodium Hydrosulfite Solution	-40/160	-40/70	A	A	A	A	A	U	X	A
Sodium Hypochlorite Solution	-65/160	-55/70	A	A	B	B	B	U	U	B
Sodium Metaphosphate Solution	-40/200	-40/95	A	A	A	B	A	X	X	X
Sodium Nitrate Solution	-65/200	-55/95	A	X	X	B	B	X	X	U
Sodium Perborate Solution	-65/200	-55/95	A	A	A	B	B	X	X	B
Sodium Peroxide Solution	-65/120	-55/50	A	A	A	B	B	U	U	U
Sodium Phosphate, Mono, Di, Tri, Solution	-40/200	-40/95	A	A	X	B	A	X	X	U
Sodium Silicate Solution	-40/200	-40/95	A	A	X	A	A	X	X	X
Sodium Sulfate (Glauber's Salts) Solution	-40/200	-40/95	A	A	A	A	A	U	A	A
Sodium Sulphhydrate Solution	-65/200	-55/95	A	A	A	A	A	U	X	A
Sodium Sulfide Solution	-65/200	-55/95	A	A	A	A	A	U	A	A
Sodium Sulfite Solution	-65/200	-55/95	A	A	A	A	A	U	U	A
Sodium Tetraborate Solution	-65/200	-55/95	A	A	A	B	B	U	X	B
Sodium Thiosulfate (or Hypo) Solution	-65/160	-55/70	A	A	A	A	B	U	A	A
Stannic Chloride Solution	-40/200	-40/95	A	A	A	U	A	X	X	B
Soy Bean Oil	-40/250	-40/120	C	A	A	C	A	A	X	A
Sperm Oil	-40/250	-40/120	U	A	A	C	A	A	X	U
Steam & Hot Water to Continuous 400° Intermittant	-65/275	-55/135	A	U	U	U	U	U	U	U
Stearic Acid	-40/250	-40/120	B	X	X	B	B	U	U	B
Stoddard Solvent	-65/250	-55/120	U	A	A	B	A	A	A	U
Styrene	-20/120	-30/50	U	A	C	U	U	U	U	U
Sugar Solutions	-65/250	-55/120	A	A	A	B	A	U	U	A
Sulfate Liquors	-40/160	-40/70	A	A	B	B	B	U	X	U
Sulfur	-65/250	-55/120	A	A	A	A	U	U	X	X
Sulfur, Chloride	-20/120	-30/50	U	A	A	U	U	U	X	C
Sulfur, Dioxide Gaseous	-65/120	-55/50	A	U	B	U	U	U	X	B
Sulfur Dioxide Liquid (Anhydrous)	-65/120	-55/50	A	U	B	U	U	U	X	B
Sulfur Hexafluoride	-65/120	-55/50	A	A	B	A	B	U	X	B
Sulfur Trioxide	-65/120	-55/50	A	A	B	U	U	U	X	B
Sulfuric Acid (0 to 50%)	-65/70	-55/20	A	A	C	C	U	U	C	U
Sulfuric Acid (Concentrated)	-20/120	-30/50	C	A	X	U	U	U	U	U
Sulphite Pulp	-20/160	-30/70	B	A	B	B	B	U	X	U
T										
Tallow - Hot	-40/200	-40/95	U	A	A	C	A	A	A	U
Tall Oil	-40/200	-40/95	U	A	A	U	A	A	A	U
Tannic Acid	-40/200	-40/95	A	A	X	B	A	U	X	B
Tanning Liquors (Vegetable)	-40/200	-40/95	A	A	X	B	A	U	X	B
Tar, Hot	-20/300	-30/150	U	A	A	C	B	U	X	B
Tetrachloroethane	-20/200	-30/95	U	A	B	U	U	U	U	U
Tetrachorethylene	-20/200	-30/95	U	A	B	U	U	U	U	U
Tetraethyl Lead	-20/120	-30/50	U	A	B	B	B	X	X	X
Tetrahydrofuran	(No Recommended Compound)									
Titanium Tetrachloride	-20/160	-30/70	U	A	B	U	B	U	U	U
Toluene (Toluol)	-20/200	-30/95	U	A	B	U	U	U	U	U
Toluene Diisocyanate	-20/120	-30/50	X	B	X	X	X	X	X	X



Table 41 Fluid and Chemical Compatibility (Continued)

MEDIUM	°F (-/+)	°C (-/+)	Ethylene Propylene	Fluoro- Carbon	Fluoro- Silicone	CR Neoprene	Nitrile	Poly- Acrylate	Poly- Urethane	Silicone (Static)
Trichloroethane	-20/200	-30/95	U	A	B	U	U	U	U	U
Trichloroethylene	-20/200	-30/95	U	A	B	U	U	U	U	U
Tricresyl Phosphate	-65/200	-55/95	A	U	U	U	U	U	U	U
Trichloro Benzene	-20/160	-30/70	X	A	U	U	X	U	U	U
Triethanolamine	-65/160	-55/70	A	X	X	X	X	U	U	U
Triethylamine	-65/160	-55/70	A	X	X	X	X	U	U	U
Tri-Normal-Butyl Phosphate	-65/250	-55/120	A	U	U	U	U	U	U	U
Trisodium Phosphate Solution	-40/200	-40/95	A	A	A	A	A	U	U	A
Tung Oil	-40/250	-40/120	U	A	A	B	A	A	A	U
Turpentine	-40/200	-40/95	U	A	A	U	A	B	B	U
U										
Ucon Hydrolubes	-40/200	-40/95	X	B	X	X	A	U	U	X
UDMH			A	U	U	U	U	U	U	U
Ultra Violet Light	-80/450	-60/230	X	X	X	X	X	X	X	A
V										
Varnish	(Depends upon composition and solvent base)									
Vegetable Juices	250	120	A	A	A	B	A	U	U	A
Vegetable Oils	-40/200	-40/95	C	A	A	C	A	A	U	B
Versilubes	-20/400	-30/205	A	A	A	B	B	A	A	U
Vinegar	200	95	A	U	C	B	B	U	U	A
Vinyl Acetate	-65/160	-55/70	B	U	X	U	U	U	U	U
Vinylidene Chloride	-20/160	-30/70	U	B	U	U	U	U	U	U
W										
Water to 275°F	33/275	1/135	A	B	A	C	U	U	U	U
Water to 180°F	33/180	1/80	A	B	A	B	B	U	U	B
Water Detergent Solution to 180°F	33/180	1/80	A	B	A	C	B	U	U	B
Water, Sea to 180°F	33/180	1/80	A	B	A	C	B	U	U	B
Water, Soap Solution to 180°F	33/180	1/80	A	B	A	C	B	U	U	B
Water, with Soluble Oil, to 180°F	33/180	1/80	U	B	B	B	A	U	U	U
Whiskey and Alcoholic Beverages	200	95	A	A	A	C	A	U	U	A
Wine	200	95	A	A	A	C	A	U	U	A
X										
Xylene (Xylol)	-20/300	-30/150	U	A	U	U	U	U	U	U
Xylydine										
Z										
Zinc Chloride Solutions, Salt Solutions	180	80	A	B	B	B	A	U	U	B



■ Description

Back-up Rings have no intended sealing function. Instead, as their name indicates, they are protective and supporting elements made from extrusion-resistant materials. They are installed in a groove together with an elastomer seal—preferably with an O-Ring or a QUAD-RING® Seal.

Due to the tight fit of the Back-up Ring in the housing, it prevents extrusion of the pressurized elastomer sealing element into the seal gap.

Back-up Rings generally have a rectangular cross-section and are specified to fit the groove dimensions of the corresponding O-Ring and QUAD-RING® Seal.

Designs

Standard designs with rectangular cross-section (Figure 40)

- Back-up Ring, Type BU, uncut

This uncut design is preferred for use for internal sealing in static applications in conjunction with O-Ring or slow dynamic applications with QUAD-RING® Seals, especially where extreme O-Ring deformations occur as a result of high pressures and high or low temperatures. An open groove is generally preferred for external sealing applications.

- Back-up Ring, Type BG, cut

The cut Back-up Ring is preferred for use in external sealing applications with static O-Ring seals.

For internal sealing applications, cut Back-up Rings offer an alternative where the uncut design cannot be fitted or if an open groove is not possible.

Cut Back-up Rings are cut at an angle of 30° or 40° so protection of the O-Ring is also ensured of the cut.

- Back-up Ring, Type BP, spiral

The spiral-type Back-up Ring consists as standard of two spiral windings. The ends of the windings are cut at an angle. This design can be used for both external sealing and internal sealing applications with static O-Ring seals.

The particular advantage of the spiral Back-up Ring is found in applications where large temperature fluctuations occur. The spiral-shaped ring can compensate for larger changes in tolerances without difficulty by a helical elongation and contraction. It can thus react more flexibly to deviations in tolerances and offers a very wide range of potential applications.

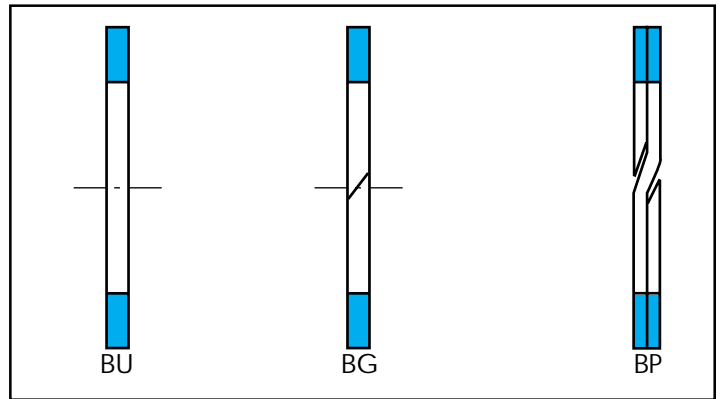

Figure 40 Back-up Ring types

Method of Operation

When exposed to high pressure, elastomer O-Rings will attempt to migrate into gaps on the low pressure side (extrusion). Under pulsating pressures there is a danger that material which has migrated into the sealing gap will be nibbled away.

This tendency to extrusion is increased with

- materials with a low Shore hardness
- large gaps
- high pressures

If, for design reasons, large sealing gaps cannot be avoided, e.g. to prevent metal to metal contact between components, the gaps can be reduced or even closed using Back-up Rings. Figure 41 shows such a situation with and without Back-up Ring.

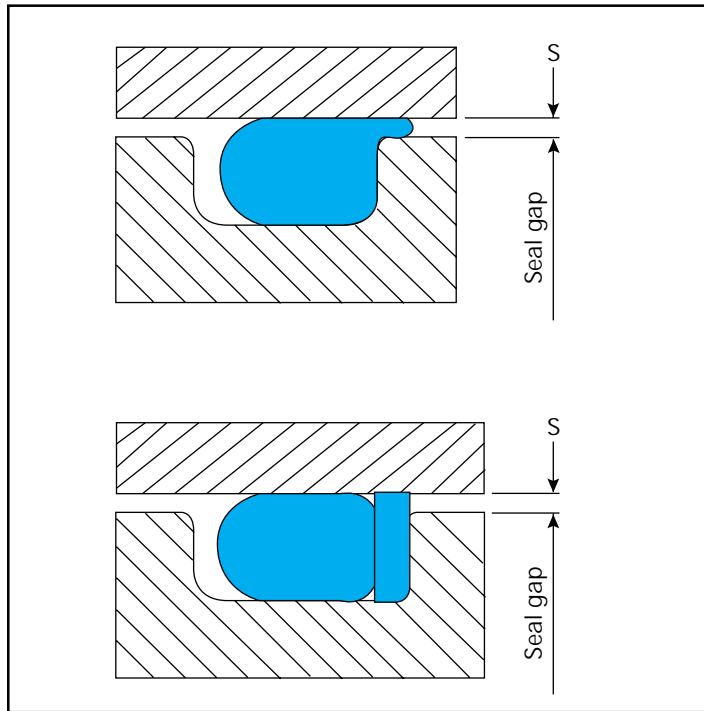

Figure 41 O-Ring installation with and without Back-up Ring

Materials

Back-up Rings are manufactured from virgin PTFE (polytetrafluoroethylene) (PT00), which can be used for pressures up to 25 MPa (3625 psi) and temperatures from -150°C to 200°C (-238°F to 392°F). For higher pressure applications filled PTFE materials (with glassfiber, bronze, carbon, etc.) have to be employed. For sealing against high pressures, Back-up Rings made from specially modified thermoplastic materials can be used. An open groove is preferred for these applications. Back-up Rings of this type can be manufactured to very close tolerances.

For the series production of larger quantities, injection molded Back-up Rings can be manufactured, e.g. in acrylonitrile butadiene rubber (NBR), 90 Shore A, or thermoplastic materials. For materials other than PTFE, please contact Busak+Shamban.

Fields of Application

Back-up Rings can be manufactured for all types of elastomer seal elements.

The use of Back-up Rings is necessary when a sealing situation involves at least one of the following operating conditions:

- Moderately high pressures above approx. 5 MPa (725 psi)
- Large tolerances between the components to be sealed or large diameter tolerances and large radial sealing gaps
- Extreme pressure pulsation and pressure cycling
- Elevated temperatures and temperature fluctuations.

Design Instructions

The recommendations for O-Rings (see "O-Rings" catalog) and for QUAD-RING® Seal (see "QUAD-RING® Seal catalog) are generally valid for the use of Back-up Rings. This applies to the groove design, surface roughness, lead-in chamfers, etc. Back-up Ring materials are chosen depending on pressure, temperature and working medium.

Where the pressure is applied from only one side, it is sufficient to install a Back-up Ring on the downstream side of the O-Ring. Where the seal is exposed to pressure from two sides, two Back-up Rings - one on each side of the O-Ring - have to be used.

To avoid possible errors in installation, it is advantageous to install two Back-up Rings even when the seal is only exposed to pressure from one side.

Groove Design

Table 42 shows recommendations for the groove design for internal and external sealing for different Back-up Ring types.

Permissible Sealing Gap

The use of Back-up Rings allows the service pressure and/or permissible sealing gap specified in our O-Ring catalog to be increased. With high service temperatures or service pressure the tolerance band H7/f7 is recommended.



Installation Instructions

Depending on the Back-up Ring type and component configuration, closed or open grooves must be provided for installation. Table 42 summarizes the possible installation arrangements.

Table 42 Groove design for Back-up Rings

Type of Back-up Ring	External sealing groove	Internal sealing groove
uncut BU	open	big diameter closed small diameter open
cut BG	closed	closed
spiral BP	closed	closed

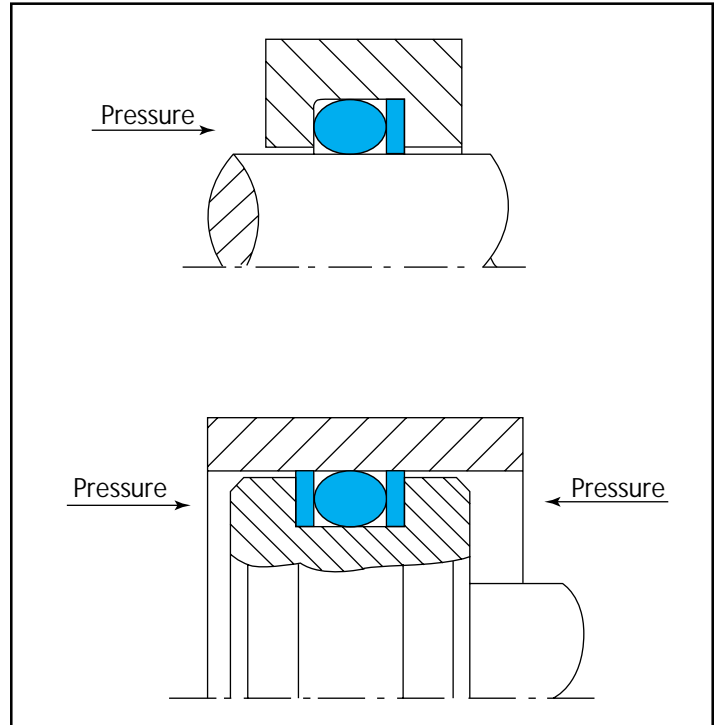
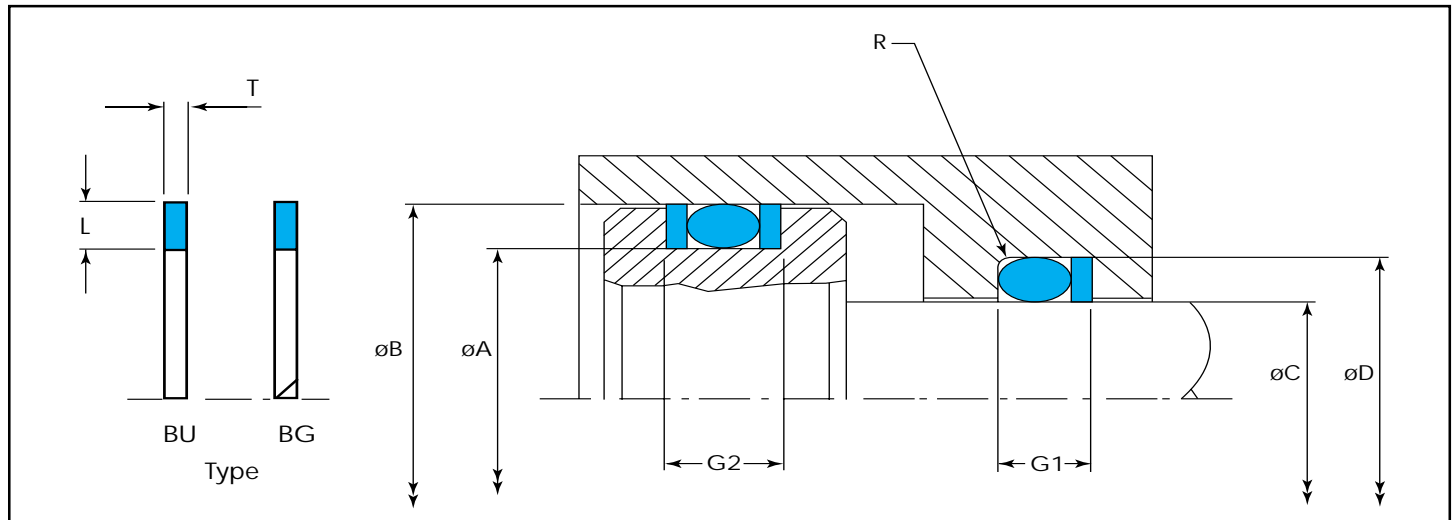

Figure 42 Back-up Ring installation, depending on the direction of the pressure

Installation Recommendations Back-up Ring, Type BU (Uncut) and Back-up Ring, Type BG (Cut) for Static Applications with O-Ring





**Table 43 Back-up Type BG (Cut) with O-Ring for Static Applications/External Sealing
Ordering Information (Metric)**

Bore B H9	Groove Diameter A h9	Groove Width		Radius R (Max)	O-Ring Part No.	Cut Back-up Ring Part No.
		G1+0,2	G2+0,2			
6,0	3,4	3,8	5,2	0,2	ORAR00006	BG1300034
8,0	5,4	3,8	5,2	0,2	ORAR00008	BG1300054
10,0	7,4	3,8	5,2	0,2	ORAR00011	BG1300074
12,0	9,4	3,8	5,2	0,2	ORAR00012	BG1300094
14,0	11,4	3,8	5,2	0,2	ORAR00013	BG1300114
15,0	12,4	3,8	5,2	0,2	ORAR00014	BG1300124
16,0	13,4	3,8	5,2	0,2	ORAR00015	BG1300134
18,0	15,4	3,8	5,2	0,2	ORAR00016	BG1300154
20,0	17,4	3,8	5,2	0,2	ORAR00017	BG1300174
22,0	19,4	3,8	5,2	0,2	ORAR00018	BG1300194
25,0	22,4	3,8	5,2	0,2	ORAR00020	BG1300224
28,0	24,0	5,0	6,4	0,3	ORAR00119	BG2000240
30,0	26,0	5,0	6,4	0,3	ORAR00120	BG2000260
32,0	28,0	5,0	6,4	0,3	ORAR00121	BG2000280
35,0	31,0	5,0	6,4	0,3	ORAR00123	BG2000310
40,0	36,0	5,0	6,4	0,3	ORAR00126	BG2000360
42,0	38,0	5,0	6,4	0,3	ORAR00127	BG2000380
45,0	41,0	5,0	6,4	0,3	ORAR00129	BG2000410
48,0	42,6	6,2	7,6	0,3	ORAR00223	BG2700426
50,0	44,6	6,2	7,6	0,3	ORAR00224	BG2700446
52,0	46,6	6,2	7,6	0,3	ORAR00224	BG2700466
55,0	49,6	6,2	7,6	0,3	ORAR00225	BG2700496
60,0	54,6	6,2	7,6	0,3	ORAR00227	BG2700546
63,0	57,6	6,2	7,6	0,3	ORAR00228	BG2700576
65,0	59,6	6,2	7,6	0,3	ORAR00228	BG2700596
70,0	64,6	6,2	7,6	0,3	ORAR00230	BG2700646
75,0	69,6	6,2	7,6	0,3	ORAR00231	BG2700696
80,0	74,6	6,2	7,6	0,3	ORAR00233	BG2700746
85,0	79,6	6,2	7,6	0,3	ORAR00235	BG2700796
90,0	81,4	8,8	10,5	0,4	ORAR00338	BG4300814
95,0	86,4	8,8	10,5	0,4	ORAR00340	BG4300864
100,0	91,4	8,8	10,5	0,4	ORAR00342	BG4300914
105,0	96,4	8,8	10,5	0,4	ORAR00343	BG4300964
110,0	101,4	8,8	10,5	0,4	ORAR00345	BG4301014
115,0	106,4	8,8	10,5	0,4	ORAR00346	BG4301064



**Table 43 Back-up Type BG (Cut) with O-Ring for Static Applications/External Sealing
Ordering Information (Metric - Continued)**

Bore B H9	Groove Diameter A h9	Groove Width		Radius R (Max)	O-Ring Part No.	Cut Back-up Ring Part No.
		G1+0,2	G2+0,2			
120,0	111,4	8,8	10,5	0,4	ORAR00348	BG4301114
125,0	116,4	8,8	10,5	0,4	ORAR00349	BG4301164
130,0	121,4	8,8	10,5	0,4	ORAR00351	BG4301214
135,0	123,4	12,0	14,5	0,6	ORAR00427	BG5801234
140,0	128,4	12,0	14,5	0,6	ORAR00429	BG5801284
150,0	138,4	12,0	14,5	0,6	ORAR00432	BG5801384
160,0	148,4	12,0	14,5	0,6	ORAR00435	BG5801484
170,0	158,4	12,0	14,5	0,6	ORAR00438	BG5801584
180,0	168,4	12,0	14,5	0,6	ORAR00439	BG5801684
190,0	178,4	12,0	14,5	0,6	ORAR00441	BG5801784
200,0	188,4	12,0	14,5	0,6	ORAR00442	BG5801884
210,0	198,4	12,0	14,5	0,6	ORAR00444	BG5801984
220,0	208,4	12,0	14,5	0,6	ORAR00445	BG5802084
230,0	218,4	12,0	14,5	0,6	ORAR00446	BG5802184
240,0	228,4	12,0	14,5	0,6	ORAR00447	BG5802284
250,0	238,4	12,0	14,5	0,6	ORAR00448	BG5802384
280,0	268,4	12,0	14,5	0,6	ORAR00450	BG5802684
300,0	288,4	12,0	14,5	0,6	ORAR00451	BG5802884
320,0	308,4	12,0	14,5	0,6	ORAR00453	BG5803084
350,0	338,4	12,0	14,5	0,6	ORAR00455	BG5803384
400,0	388,4	12,0	14,5	0,6	ORAR00459	BG5803884
420,0	408,4	12,0	14,5	0,6	ORAR00461	BG5804084
450,0	438,4	12,0	14,5	0,6	ORAR00463	BG5804384
480,0	468,4	12,0	14,5	0,6	ORAR00465	BG5804684
500,0	488,4	12,0	14,5	0,6	ORAR00467	BG5804884

All **Bold** dimensions are recommended by ISO 3320.

Ordering Example

Back-up Ring: Type BG (cut) for O-Ring Seal
 Application: Static, external sealing
 Bore diameter: B = 100,0 mm
 Radial Height: L = 4,3 mm
 Back-up Ring material: PTFE

Order No.	BG	43	00920	-	PT00
Back-up Ring Type					
Radial height L x 10					
Groove diameter A x 10					
Quality Index (Standard)					
Compound No.					



**Table 44 Back-up Type BU (Uncut) with O-Ring for Static Applications/Internal Sealing
Ordering Information (Metric)**

Rod C f8	Groove Diameter D H9	Groove Width		Radius R (Max)	O-Ring Part No.	Uncut Back-up Ring Part No.
		G1+0,2	G2+0,2			
4,0	6,6	3,8	5,2	0,2	ORAR00007	BU1300040
5,0	7,6	3,8	5,2	0,2	ORAR00008	BU1300050
6,0	8,6	3,8	5,2	0,2	ORAR00010	BU1300060
8,0	10,6	3,8	5,2	0,2	ORAR00011	BU1300080
10,0	12,6	3,8	5,2	0,2	ORAR00013	BU1300100
12,0	14,6	3,8	5,2	0,2	ORAR00014	BU1300120
14,0	16,6	3,8	5,2	0,2	ORAR00015	BU1300140
15,0	17,6	3,8	5,2	0,2	ORAR00016	BU1300150
16,0	18,6	3,8	5,2	0,2	ORAR00016	BU1300160
18,0	20,6	3,8	5,2	0,2	ORAR00018	BU1300180
20,0	22,6	3,8	5,2	0,2	ORAR00019	BU1300200
22,0	26,0	5,0	6,4	0,3	ORAR00118	BU2000220
25,0	29,0	5,0	6,4	0,3	ORAR00120	BU2000250
28,0	32,0	5,0	6,4	0,3	ORAR00122	BU2000280
30,0	34,0	5,0	6,4	0,3	ORAR00123	BU2000300
32,0	36,0	5,0	6,4	0,3	ORAR00124	BU2000320
35,0	39,0	5,0	6,4	0,3	ORAR00126	BU2000350
36,0	40,0	5,0	6,4	0,3	ORAR00127	BU2000360
40,0	45,4	6,2	7,6	0,4	ORAR00223	BU2700400
42,0	47,4	6,2	7,6	0,4	ORAR00223	BU2700420
45,0	50,4	6,2	7,6	0,4	ORAR00224	BU2700450
48,0	53,4	6,2	7,6	0,4	ORAR00225	BU2700480
50,0	55,4	6,2	7,6	0,4	ORAR00226	BU2700500
52,0	57,4	6,2	7,6	0,4	ORAR00226	BU2700520
55,0	60,4	6,2	7,6	0,4	ORAR00227	BU2700550
56,0	61,4	6,2	7,6	0,4	ORAR00228	BU2700560
60,0	65,4	6,2	7,6	0,4	ORAR00229	BU2700600
63,0	68,4	6,2	7,6	0,4	ORAR00230	BU2700630
65,0	70,4	6,2	7,6	0,4	ORAR00231	BU2700650
70,0	75,4	6,2	7,6	0,4	ORAR00232	BU2700700
75,0	80,4	6,2	7,6	0,4	ORAR00234	BU2700750
80,0	88,6	8,8	10,5	0,4	ORAR00339	BU4300800
85,0	93,6	8,8	10,5	0,4	ORAR00340	BU4300850
90,0	98,6	8,8	10,5	0,4	ORAR00342	BU4300900
95,0	103,6	8,8	10,5	0,4	ORAR00343	BU4300950



**Table 44 Back-up Type BU (Uncut) with O-Ring for Static Applications/Internal Sealing
Ordering Information (Metric- Continued)**

Rod C f8	Groove Diameter D H9	Groove Width		Radius R (Max)	O-Ring Part No.	Uncut Back-up Ring Part No.
		G1+0,2	G2+0,2			
100,0	108,6	8,8	10,5	0,4	ORAR00345	BU4301000
105,0	113,6	8,8	10,5	0,4	ORAR00346	BU4301050
110,0	118,6	8,8	10,5	0,4	ORAR00348	BU4301100
115,0	123,6	8,8	10,5	0,4	ORAR00349	BU4301150
120,0	128,6	8,8	10,5	0,4	ORAR00351	BU4301200
125,0	133,6	8,8	10,5	0,4	ORAR00353	BU4301250
130,0	138,6	8,8	10,5	0,4	ORAR00354	BU4301300
135,0	146,6	12,0	14,5	0,6	ORAR00432	BU5801350
140,0	151,6	12,0	14,5	0,6	ORAR00433	BU5801400
150,0	161,6	12,0	14,5	0,6	ORAR00437	BU5801500
160,0	171,6	12,0	14,5	0,6	ORAR00438	BU5801600
170,0	181,6	12,0	14,5	0,6	ORAR00440	BU5801700
180,0	191,6	12,0	14,5	0,6	ORAR00442	BU5801800
190,0	201,6	12,0	14,5	0,6	ORAR00443	BU5801900
200,0	211,6	12,0	14,5	0,6	ORAR00445	BU5802000
210,0	221,6	12,0	14,5	0,6	ORAR00446	BU5802100
220,0	231,6	12,0	14,5	0,6	ORAR00446	BU5802200
230,0	241,6	12,0	14,5	0,6	ORAR00447	BU5802300
240,0	251,6	12,0	14,5	0,6	ORAR00448	BU5802400
250,0	261,6	12,0	14,5	0,6	ORAR00449	BU5802500
280,0	291,6	12,0	14,5	0,6	ORAR00451	BU5802800
300,0	311,6	12,0	14,5	0,6	ORAR00453	BU5803000
320,0	331,6	12,0	14,5	0,6	ORAR00454	BU5803200
350,0	361,6	12,0	14,5	0,6	ORAR00457	BU5803500
360,0	371,6	12,0	14,5	0,6	ORAR00457	BU5803600
400,0	411,6	12,0	14,5	0,6	ORAR00461	BU5804000

All **Bold** dimensions are recommended by ISO 3320.

Ordering Example

Back-up Ring: Type BU (uncut) for O-Ring Seal
 Application: Static, internal sealing
 Rod diameter: C = 63,0 mm
 Radial height: L = 2,7 mm
 Back-up Ring material: PTFE

Order No.	BU	27	00630	-	PT00
Back-up Ring Type					
Radial height L x 10					
Rod diameter C x 10					
Quality Index (Standard)					
Compound No.					



■ General

The QUAD-RING® Seal is a four-lip seal used and handled much like O-Rings. But where O-Rings have drawbacks, the QUAD-RING® Seal achieves a substantially more efficient seal. Application ranges are extensive due to the many types of synthetic rubber available today.

Advantages

The QUAD-RING® Seal has several advantages over O-Rings:

- No likelihood of twisting from reciprocating motion
- Less friction because it requires less radial pre-stressing which lessens contact pressure
- Less leakage because contact pressure is evenly distributed
- No interfering flash because the mold parting line is located between the lips affecting the seal
- Long life and better sealing in dynamic applications

Fields of Application

The QUAD-RING® Seal can be used in either dynamic or static applications. However, it is most often used for slow dynamic or rotary applications because the O-Ring is more economical for static applications.

- **Dynamic seals** : for reciprocating pistons, rods, plungers, etc., and for shafts, spindles, etc. subjected to slewing, spiral and rotary motion
- **Static seals** : radial and axial seals for bushings, flanges, covers, etc.

Operating Ranges

- Pressure: up to approximately 40 MPa (5800 psi) (together with PTFE back-up rings)
- Speed: up to approximately 0.5 m/s(1.6 ft/s) (reciprocating motion) Special design dimensions available for rotary applications
- Temperature: approx. -100°C to +260°C (-148°F to +500° F) (depending on QUAD-RING® Seal compound)

® QUAD-RING is a registered trademark of Quadion Corporation

Method of Operation

The QUAD-RING® Seal is a pressure energized, double-acting seal. It is an endless, circular ring with an almost square cross section which is produced by vulcanizing in the mold. Radial and axial force are dependent upon the system pressure. The result is an increase in the compression of the seal as the pressure rises.

Selection of QUAD-RING® Seal

If the bore or rod diameter is known, the following principles apply for selecting the most suitable sized QUAD-RING® Seal:

For External Seals Installation:

The inside diameter of the QUAD-RING® Seal should be the same as that of the corresponding groove or approximately 2% less. The QUAD-RING® Seal is thereby prevented from twisting, because it is slightly prestressed in the groove.

For Internal Seals Installation:

The inside diameter of the QUAD-RING® Seal should be equal or approximately .2 to .3 mm smaller than the corresponding rod. It may also be about 1% larger than the corresponding shaft diameter. In this case, the ring can be more easily installed and will have a longer life.

Usually a ring with a comparatively thin cross section will suffice for static seals, whereas a ring of greater width should be selected for dynamic seals. In general, the greater the pressure and the larger the gap, the harder the compound should be in order to avoid extrusion into the gap. However, a better solution, would be to select a compound of average hardness (70 Shore) and to install a PTFE back-up ring. X-sel coating is also available for friction reduction.

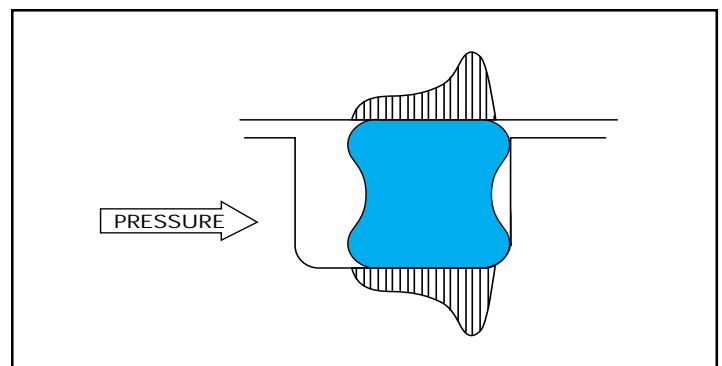

Figure 43 QUAD-RING® Seal load distribution profile



QUAD-RING® Seal Dimensional Data

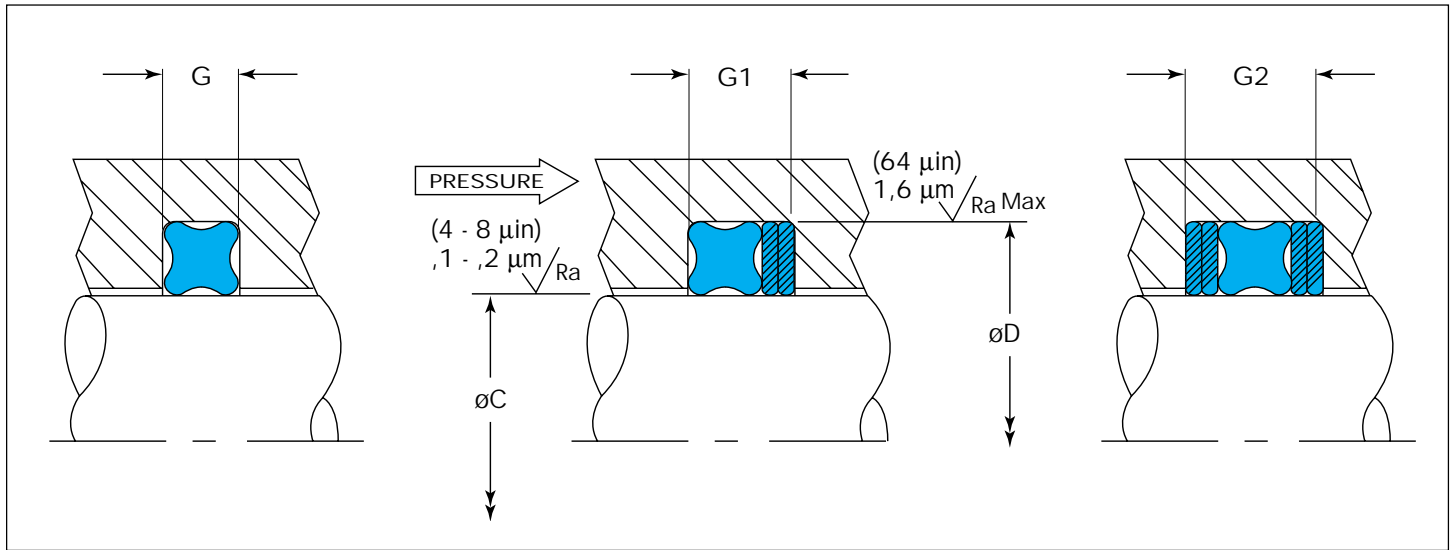

Table 45 QUAD-RING® Seal Ordering Information for Reciprocating Rod Sealing (Metric)

Rod C f8	Groove Diameter D H9	Groove Width (+ 0,2)			QUAD-RING® Seal	Spiral Back-up Ring
		G	G1	G2	Part Number	Part Number
4,0	7,0	2,0	3,4	4,8	QRAR04008	BP1500040
5,0	8,0	2,0	3,4	4,8	QRAR04009	BP1500050
6,0	9,0	2,0	3,4	4,8	QRAR04010	BP1500060
8,0	11,0	2,0	3,4	4,8	QRAR04012A	BP1500080
10,0	14,6	3,0	4,4	5,8	QRAR4111A	BP2300100
12,0	16,6	3,0	4,4	5,8	QRAR04112	BP2300120
14,0	18,6	3,0	4,4	5,8	QRAR04113	BP2300140
15,0	19,6	3,0	4,4	5,8	QRAR4114A	BP2300150
16,0	20,6	3,0	4,4	5,8	QRAR4115A	BP2300160
18,0	24,4	4,0	5,4	6,8	QRAR4210A	BP3200180
20,0	26,4	4,0	5,4	6,8	QRAR04211	BP3200200
22,0	28,4	4,0	5,4	6,8	QRAR04212	BP3200220
25,0	31,4	4,0	5,4	6,8	QRAR04214	BP3200250
28,0	34,4	4,0	5,4	6,8	QRAR04216	BP3200280
30,0	36,4	4,0	5,4	6,8	QRAR04217	BP3200300
32,0	38,4	4,0	5,4	6,8	QRAR04218	BP3200320
35,0	41,4	4,0	5,4	6,8	QRAR04220	BP3200350
36,0	42,4	4,0	5,4	6,8	QRAR04221	BP3200360
40,0	49,8	6,0	7,7	9,4	QRAR04326	BP4900400
42,0	51,8	6,0	7,7	9,4	QRAR04326	BP4900420



Table 45 QUAD-RING® Seal Ordering Information for Reciprocating Rod Sealing (Metric-Continued)

Rod C f8	Groove Diameter D H9	Groove Width (+ 0,2)			QUAD-RING® Seal	Spiral Back-up Ring
		G	G1	G2	Part Number	Part Number
45,0	54,8	6,0	7,7	9,4	QRAR4328A	BP4900450
48,0	57,8	6,0	7,7	9,4	QRAR04328	BP4900480
50,0	59,8	6,0	7,7	9,4	QRAR04329	BP4900500
52,0	61,8	6,0	7,7	9,4	QRAR04329	BP4900520
55,0	64,8	6,0	7,7	9,4	QRAR04330	BP4900550
56,0	65,8	6,0	7,7	9,4	QRAR04331	BP4900560
60,0	69,8	6,0	7,7	9,4	QRAR04332	BP4900600
63,0	72,8	6,0	7,7	9,4	QRAR04333	BP4900630
65,0	74,8	6,0	7,7	9,4	QRAR04334	BP4900650
70,0	79,8	6,0	7,7	9,4	QRAR04335	BP4900700
75,0	84,8	6,0	7,7	9,4	QRAR04337	BP4900750
80,0	89,8	6,0	7,7	9,4	QRAR04338	BP4900800
85,0	94,8	6,0	7,7	9,4	QRAR04340	BP4900850
90,0	99,8	6,0	7,7	9,4	QRAR04342	BP4900900
100,0	109,8	6,0	7,7	9,4	QRAR04345	BP4901000
105,0	114,8	6,0	7,7	9,4	QRAR04346	BP4901050
110,0	119,8	6,0	7,7	9,4	QRAR04348	BP4901100
115,0	127,8	8,0	10,5	13,0	QRAR04426	BP6401150
120,0	132,8	8,0	10,5	13,0	QRAR04427	BP6401200
125,0	137,8	8,0	10,5	13,0	QRAR04429	BP6401250
130,0	142,8	8,0	10,5	13,0	QRAR04430	BP6401300
135,0	147,8	8,0	10,5	13,0	QRAR04432	BP6401350
140,0	152,8	8,0	10,5	13,0	QRAR04433	BP6401400
150,0	162,8	8,0	10,5	13,0	QRAR04436	BP6401500
160,0	172,8	8,0	10,5	13,0	QRAR4439A	BP6401600
170,0	182,8	8,0	10,5	13,0	QRAR04440	BP6401700
180,0	192,8	8,0	10,5	13,0	QRAR04441	BP6401800
190,0	202,8	8,0	10,5	13,0	QRAR04443	BP6401900
200,0	212,8	8,0	10,5	13,0	QRAR04445	BP6402000
210,0	222,8	8,0	10,5	13,0	QRAR04446	BP6402100
220,0	232,8	8,0	10,5	13,0	QRAR04446	BP6402200
230,0	242,8	8,0	10,5	13,0	QRAR04447	BP6402300
240,0	252,8	8,0	10,5	13,0	QRAR04448	BP6402400
250,0	262,8	8,0	10,5	13,0	QRAR04449	BP6402500
280,0	292,8	8,0	10,5	13,0	QRAR04451	BP6402800



Table 45 QUAD-RING® Seal Ordering Information for Reciprocating Rod Sealing (Metric-Continued)

Rod C f8	Groove Diameter D H9	Groove Width (+ 0,2)			QUAD-RING® Seal Part Number	Spiral Back-up Ring Part Number
		G	G1	G2		
300,0	312,8	8,0	10,5	13,0	QRAR04453	BP6403000
320,0	332,8	8,0	10,5	13,0	QRAR04454	BP6403200
350,0	362,8	8,0	10,5	13,0	QRAR04457	BP6403500
360,0	372,8	8,0	10,5	13,0	QRAR04457	BP6403600
400,0	412,8	8,0	10,5	13,0	QRAR04461	BP6404000

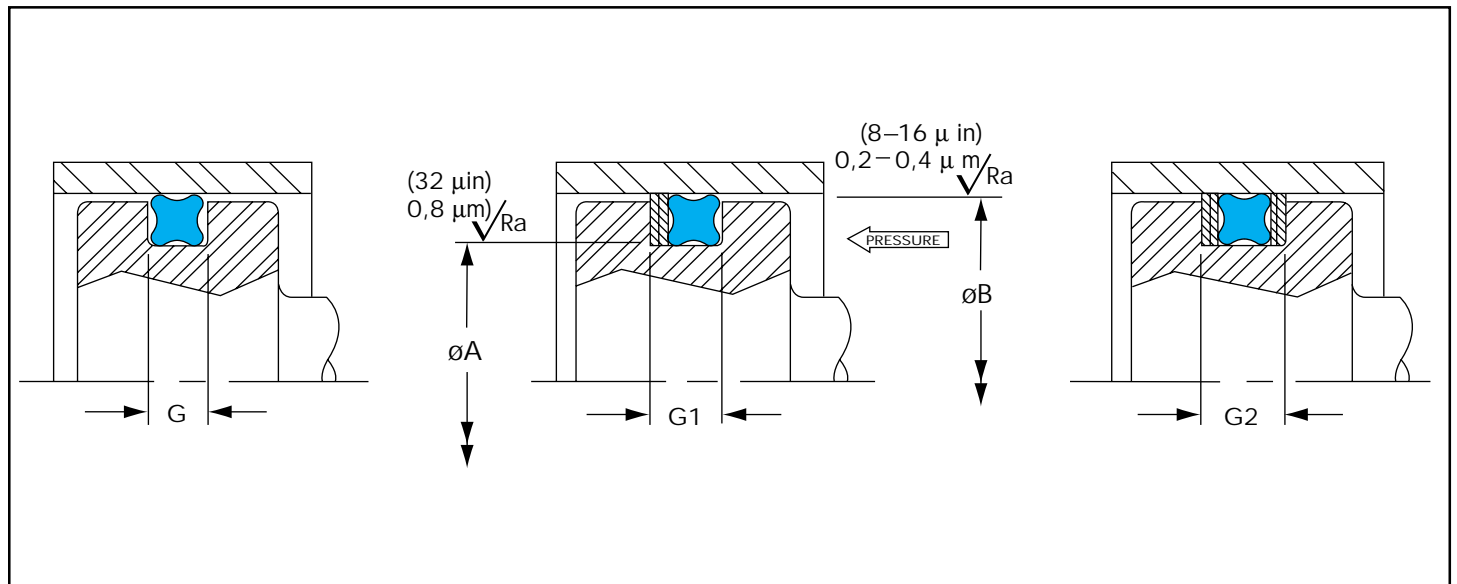

Table 46 QUAD-RING® Seal Ordering Information for Reciprocating Piston Sealing (Metric)

Bore BH9	Groove Diameter A h9	Groove Width (+ 0,2)			QUAD-RING® Seal Part Number	Spiral Back-up Ring Part Number
		G	G1	G2		
6,0	3,0	2,0	3,4	4,4	QRAR04005	BP1500030
8,0	5,0	2,0	3,4	4,4	QRAR04008	BP1500050
10,0	7,0	2,0	3,4	4,4	QRAR40010	BP1500070
12,0	9,0	2,0	3,4	4,4	QRAR4012A	BP1500090
14,0	11,0	2,0	3,4	4,4	QRAR04013	BP1500110
15,0	10,4	3,0	4,4	5,8	QRAR4111A	BP2300104
16,0	11,4	3,0	4,4	5,8	QRAR04111	BP2300114
18,0	13,4	3,0	4,4	5,8	QRAR04112	BP2300134
20,0	15,4	3,0	4,4	5,8	QRAR4114A	BP2300154
22,0	17,4	3,0	4,4	5,8	QRAR04115	BP2300174



Table 46 QUAD-RING® Seal Ordering Information for Reciprocating Piston Sealing
(Metric-Continued)

Bore BH9	Groove Diameter A h9	Groove Width (+ 0,2)			QUAD-RING® Seal Part Number	Spiral Back-up Ring Part Number
		G	G1	G2		
25,0	18,6	4,0	5,4	6,8	QRAR4210A	BP3200186
28,0	21,6	4,0	5,4	6,8	QRAR04212	BP3200216
30,0	23,6	4,0	5,4	6,8	QRAR04213	BP3200236
32,0	25,6	4,0	5,4	6,8	QRAR04214	BP3200256
35,0	28,6	4,0	5,4	6,8	QRAR04216	BP3200286
40,0	33,6	4,0	5,4	6,8	QRAR04219	BP3200336
42,0	35,6	4,0	5,4	6,8	QRAR04220	BP3200356
45,0	38,6	4,0	5,4	6,8	QRAR04222	BP3200386
48,0	38,2	6,0	7,7	9,4	QRAR04325	BP4900382
50,0	40,2	6,0	7,7	9,4	QRAR4326A	BP4900402
52,0	42,2	6,0	7,7	9,4	QRAR04326	BP4900422
55,0	45,2	6,0	7,7	9,4	QRAR04327	BP4900452
60,0	50,2	6,0	7,7	9,4	QRAR04329	BP4900502
63,0	53,2	6,0	7,7	9,4	QRAR04330	BP4900532
65,0	55,2	6,0	7,7	9,4	QRAR04330	BP4900552
70,0	60,2	6,0	7,7	9,4	QRAR04332	BP4900602
75,0	65,2	6,0	7,7	9,4	QRAR04333	BP4900652
80,0	70,2	6,0	7,7	9,4	QRAR04335	BP4900702
85,0	75,2	6,0	7,7	9,4	QRAR04337	BP4900752
90,0	80,2	6,0	7,7	9,4	QRAR04338	BP4900802
95,0	85,2	6,0	7,7	9,4	QRAR04340	BP4900852
100,0	90,2	6,0	7,7	9,4	QRAR04342	BP4900902
105,0	95,2	6,0	7,7	9,4	QRAR04343	BP4900952
110,0	100,2	6,0	7,7	9,4	QRAR04345	BP4901002
115,0	105,2	6,0	7,7	9,4	QRAR04346	BP4901052
120,0	110,2	6,0	7,7	9,4	QRAR04348	BP4901102
125,0	115,2	6,0	7,7	9,4	QRAR04349	BP4901152
130,0	120,2	6,0	7,7	9,4	QRAR04351	BP4901202
135,0	122,2	8,0	10,5	13,0	QRAR04427	BP6401222
140,0	127,2	8,0	10,5	13,0	QRAR04429	BP6401272
150,0	137,2	8,0	10,5	13,0	QRAR04432	BP6401372
160,0	147,2	8,0	10,5	13,0	QRAR04435	BP6401472
170,0	157,2	8,0	10,5	13,0	QRAR04438	BP6401572
180,0	167,2	8,0	10,5	13,0	QRAR04439	BP6401672
190,0	177,2	8,0	10,5	13,0	QRAR04441	BP6401772



Table 46 QUAD-RING® Seal Ordering Information for Reciprocating Piston Sealing (Metric-Continued)

Bore BH9	Groove Diameter A h9	Groove Width (+ 0,2)			QUAD-RING® Seal Part Number	Spiral Back-up Ring Part Number
		G	G1	G2		
200,0	187,2	8,0	10,5	13,0	QRAR04442	BP6401872
210,0	197,2	8,0	10,5	13,0	QRAR04444	BP6401972
220,0	207,2	8,0	10,5	13,0	QRAR04445	BP6402072
230,0	217,2	8,0	10,5	13,0	QRAR04446	BP6402172
240,0	227,2	8,0	10,5	13,0	QRAR04447	BP6402272
250,0	237,2	8,0	10,5	13,0	QRAR04447	BP6402372
280,0	267,2	8,0	10,5	13,0	QRAR04450	BP6402672
300,0	287,2	8,0	10,5	13,0	QRAR04451	BP6402872
320,0	307,2	8,0	10,5	13,0	QRAR04453	BP6403072
350,0	337,2	8,0	10,5	13,0	QRAR04455	BP6403372
400,0	387,2	8,0	10,5	13,0	QRAR04459	BP6403872
420,0	407,2	8,0	10,5	13,0	QRAR04461	BP6404072
450,0	437,2	8,0	10,5	13,0	QRAR04463	BP6404372
480,0	467,2	8,0	10,5	13,0	QRAR04465	BP6404672
500,0	487,2	8,0	10,5	13,0	QRAR04467	BP6404872

Table 47 QUAD-RING® Seal and Back-up Ring (cut) Ordering Information for Reciprocating Rod Sealing (Imperial)

Rod Diameter C f8	Groove Diameter D H9	Groove Width (+ .008)			QUAD-RING® Seal Part Number	Spiral Back-up Ring Part Number
		G	G1	G2		
.500	.620	.080	.136	.191	QRAR04014	BP15L0127
.625	.745	.080	.136	.191	QRAR04016	BP15L0159
.750	.870	.080	.136	.191	QRAR04018	BP15L0191
.875	.995	.080	.136	.191	QRAR04020	BP15L0222
1.000	1.186	.115	.171	.226	QRAR04120	BP23L0254
1.125	1.311	.115	.171	.226	QRAR04122	BP23L0286
1.250	1.435	.115	.171	.226	QRAR04124	BP23L0318
1.375	1.560	.115	.171	.226	QRAR04126	BP23L0349
1.500	1.685	.115	.171	.226	QRAR04128	BP23L0381
1.625	1.810	.115	.171	.226	QRAR04130	BP23L0413
1.750	2.003	.155	.222	.289	QRAR04224	BP32O0445
1.875	2.128	.155	.222	.289	QRAR04225	BP32O0476
2.000	2.253	.155	.222	.289	QRAR04226	BP32O0508
2.125	2.387	.155	.222	.289	QRAR04227	BP32O0540
2.250	2.503	.155	.222	.289	QRAR04228	BP32O0572



Table 47 QUAD-RING® Seal and Back-up Ring (cut) Ordering Information for Reciprocating Rod Sealing (Imperial - Continued)

Rod Diameter C f8	Groove Diameter D H9	Groove Width (+ .008)			QUAD-RING® Seal Part Number	Spiral Back-up Ring Part Number
		G	G1	G2		
2.375	2.628	.155	.222	.289	QRAR04229	BP32O0603
2.500	2.753	.155	.222	.289	QRAR04230	BP32O0635
2.625	2.878	.155	.222	.289	QRAR04231	BP32O0668
2.750	3.003	.155	.222	.289	QRAR04232	BP32O0699
2.875	3.128	.155	.222	.289	QRAR04233	BP32O0730
3.000	3.389	.240	.307	.374	QRAR04337	BP49O0762
3.125	3.514	.240	.307	.374	QRAR04338	BP49O0794
3.250	3.638	.240	.307	.374	QRAR04339	BP49O0826
3.375	3.763	.240	.307	.374	QRAR04340	BP49O0857
3.500	3.888	.240	.307	.374	QRAR04341	BP49O0889
3.625	4.013	.240	.307	.374	QRAR04342	BP49O0921
3.750	4.138	.240	.307	.374	QRAR04343	BP49O0953
3.875	4.263	.240	.307	.374	QRAR04344	BP49O0984
4.000	4.388	.240	.307	.374	QRAR04345	BP49O1016
4.125	4.513	.240	.307	.374	QRAR04346	BP49O1048
4.250	4.638	.240	.307	.374	QRAR04347	BP49O1080
4.375	4.763	.240	.307	.374	QRAR04348	BP49O1111
4.500	4.888	.240	.307	.374	QRAR04349	BP49O1143
4.625	5.013	.240	.307	.374	QRAR04350	BP49O1175
4.750	5.138	.240	.307	.374	QRAR04351	BP49O1207
4.875	5.263	.240	.307	.374	QRAR04352	BP49O1238
5.000	5.388	.240	.307	.374	QRAR04353	BP49O1270
5.125	5.513	.240	.307	.374	QRAR04354	BP49O1302
5.250	5.638	.240	.307	.374	QRAR04355	BP49O1334
5.375	5.763	.240	.307	.374	QRAR04356	BP49O1365
5.500	5.888	.240	.307	.374	QRAR04357	BP49O1397
5.625	6.013	.240	.307	.374	QRAR04358	BP49O1429
5.750	6.138	.240	.307	.374	QRAR04359	BP49O1461
5.875	6.263	.240	.307	.374	QRAR04360	BP49O1492
6.000	6.508	.310	.409	.507	QRAR04437	BP64T1524
6.250	6.758	.310	.409	.507	QRAR04438	BP64T1588
6.500	7.008	.310	.409	.507	QRAR04439	BP64T1651
6.750	7.258	.310	.409	.507	QRAR04440	BP64T1715
7.000	7.508	.310	.409	.507	QRAR04441	BP64T1778
7.250	7.757	.310	.409	.507	QRAR04442	BP64T1842



Table 47 QUAD-RING® Seal and Back-up Ring (cut) Ordering Information for Reciprocating Rod Sealing (Imperial - Continued)

Rod Diameter C f8	Groove Diameter D H9	Groove Width (+ .008)			QUAD-RING® Seal Part Number	Spiral Back-up Ring Part Number
		G	G1	G2		
7.500	8.007	.310	.409	.507	QRAR04443	BP64T1905
7.750	8.257	.310	.409	.507	QRAR04444	BP64T1969
8.000	8.507	.310	.409	.507	QRAR04445	BP64T2032
8.500	9.007	.310	.409	.507	QRAR04446	BP64T2159
9.000	9.507	.310	.409	.507	QRAR04447	BP64T2286
9.500	10.007	.310	.409	.507	QRAR04448	BP64T2413
10.000	10.507	.310	.409	.507	QRAR04449	BP64T2540
10.500	11.007	.310	.409	.507	QRAR04450	BP64T2667
11.000	11.507	.310	.409	.507	QRAR04451	BP64T2794
11.500	12.007	.310	.409	.507	QRAR04452	BP64T2921
12.000	12.507	.310	.409	.507	QRAR04453	BP64T3048
12.500	13.006	.310	.409	.507	QRAR04454	BP64T3175
13.000	13.506	.310	.409	.507	QRAR04455	BP64T3302
13.500	14.006	.310	.409	.507	QRAR04456	BP64T3429
14.000	14.506	.310	.409	.507	QRAR04457	BP64T3556
14.500	15.006	.310	.409	.507	QRAR04458	BP64T3683
15.000	15.506	.310	.409	.507	QRAR04459	BP64T3810
15.500	16.006	.310	.409	.507	QRAR04460	BP64T3937
16.000	16.505	.310	.409	.507	QRAR04461	BP64T4064
16.500	17.005	.310	.409	.507	QRAR04462	BP64T4191
17.000	17.505	.310	.409	.507	QRAR04463	BP64T4318
17.500	18.005	.310	.409	.507	QRAR04464	BP64T4445
18.000	18.505	.310	.409	.507	QRAR04465	BP64T4572
18.500	19.005	.310	.409	.507	QRAR04466	BP64T4699
19.000	19.505	.310	.409	.507	QRAR04467	BP64T4826
19.500	20.005	.310	.409	.507	QRAR04468	BP64T4953
20.000	20.505	.310	.409	.507	QRAR04469	BP64T5080



Table 48 QUAD-RING® Seal and Back-up Ring (cut) Ordering Information for Reciprocating Piston Sealing (Imperial)

Bore Diameter B H9	Groove Diameter A h9	Groove Width (+ .008)			QUAD-RING® Seal Part Number	Spiral Back-up Ring Part Number
		G	G1	G2		
.500	.380	.080	.136	.191	QRAR04012	BP15L0096
.625	.505	.080	.136	.191	QRAR04014	BP15L0128
.750	.630	.080	.136	.191	QRAR04016	BP15L0160
.875	.755	.080	.136	.191	QRAR04018	BP15L0192
1.000	.880	.080	.136	.191	QRAR04020	BP15L0224
1.125	.939	.115	.171	.226	QRAR04119	BP23L0239
1.250	1.064	.115	.171	.226	QRAR04121	BP23L0270
1.375	1.189	.115	.171	.226	QRAR04123	BP23L0302
1.500	1.314	.115	.171	.226	QRAR04125	BP23L0334
1.625	1.371	.155	.222	.289	QRAR04220	BP32O0348
1.750	1.496	.155	.222	.289	QRAR04222	BP32O0380
1.875	1.621	.155	.222	.289	QRAR04223	BP32O0412
2.000	1.747	.155	.222	.289	QRAR04224	BP32O0444
2.125	1.872	.155	.222	.289	QRAR04225	BP32O0475
2.250	1.997	.155	.222	.289	QRAR04226	BP32O0507
2.375	2.122	.155	.222	.289	QRAR04227	BP32O0539
2.500	2.247	.155	.222	.289	QRAR04228	BP32O0571
2.625	2.372	.155	.222	.289	QRAR04229	BP32O0602
2.750	2.497	.155	.222	.289	QRAR04230	BP32O0634
2.875	2.622	.155	.222	.289	QRAR04231	BP32O0666
3.000	2.611	.240	.307	.374	QRAR04334	BP49O0663
3.125	2.736	.240	.307	.374	QRAR04335	BP49O0695
3.250	2.861	.240	.307	.374	QRAR04336	BP49O0727
3.375	2.986	.240	.307	.374	QRAR04337	BP49O0759
3.500	3.111	.240	.307	.374	QRAR04338	BP49O0790
3.625	3.236	.240	.307	.374	QRAR04339	BP49O0822
3.750	3.361	.240	.307	.374	QRAR04340	BP49O0854
3.875	3.486	.240	.307	.374	QRAR04341	BP49O0886
4.000	3.611	.240	.307	.374	QRAR04342	BP49O0917
4.125	3.736	.240	.307	.374	QRAR04343	BP49O0949
4.250	3.861	.240	.307	.374	QRAR04344	BP49O0981
4.375	3.986	.240	.307	.374	QRAR04345	BP49O1013
4.500	4.111	.240	.307	.374	QRAR04346	BP49O1044
4.625	4.236	.240	.307	.374	QRAR04347	BP49O1076
4.750	4.362	.240	.307	.374	QRAR04348	BP49O1108



Table 48 QUAD-RING® Seal and Back-up Ring (cut) Ordering Information for Reciprocating Piston Sealing (Imperial- Continued)

Bore Diameter B H9	Groove Diameter A h9	Groove Width (+ .008)			QUAD-RING® Seal Part Number	Spiral Back-up Ring Part Number
		G	G1	G2		
4.875	4.487	.240	.307	.374	QRAR04349	BP49O1140
5.000	4.612	.240	.307	.374	QRAR04350	BP49O1171
5.125	4.737	.240	.307	.374	QRAR04351	BP49O1203
5.250	4.862	.240	.307	.374	QRAR04352	BP49O1235
5.375	4.987	.240	.307	.374	QRAR04353	BP49O1267
5.500	5.112	.240	.307	.374	QRAR04354	BP49O1298
5.625	5.237	.240	.307	.374	QRAR04355	BP49O1330
5.750	5.362	.240	.307	.374	QRAR04356	BP49O1362
5.875	5.487	.240	.307	.374	QRAR04357	BP49O1394
6.000	5.492	.310	.409	.507	QRAR04433	BP64T1395
6.250	5.742	.310	.409	.507	QRAR04435	BP64T1458
6.500	5.992	.310	.409	.507	QRAR04437	BP64T1522
6.750	6.242	.310	.409	.507	QRAR04438	BP64T1585
7.000	6.492	.310	.409	.507	QRAR04439	BP64T1649
7.250	6.743	.310	.409	.507	QRAR04440	BP64T1713
7.500	6.993	.310	.409	.507	QRAR04441	BP64T1776
7.750	7.243	.310	.409	.507	QRAR04442	BP64T1840
8.000	7.493	.310	.409	.507	QRAR04443	BP64T1903
8.500	7.993	.310	.409	.507	QRAR04445	BP64T2030
9.000	8.493	.310	.409	.507	QRAR04446	BP64T2157
9.500	8.993	.310	.409	.507	QRAR04447	BP64T2284
10.000	9.493	.310	.409	.507	QRAR04448	BP64T2411
10.500	9.993	.310	.409	.507	QRAR04449	BP64T2538
11.000	10.493	.310	.409	.507	QRAR04450	BP64T2665
11.500	10.993	.310	.409	.507	QRAR04451	BP64T2792
12.000	11.493	.310	.409	.507	QRAR04452	BP64T2919
12.500	11.994	.310	.409	.507	QRAR04453	BP64T3046
13.000	12.494	.310	.409	.507	QRAR04454	BP64T3173
13.500	12.994	.310	.409	.507	QRAR04455	BP64T3300
14.000	13.494	.310	.409	.507	QRAR04456	BP64T3427
14.500	13.994	.310	.409	.507	QRAR04457	BP64T3554
15.000	14.494	.310	.409	.507	QRAR04458	BP64T3681
15.500	14.994	.310	.409	.507	QRAR04459	BP64T3808
16.000	15.494	.310	.409	.507	QRAR04460	BP64T3936
16.500	15.994	.310	.409	.507	QRAR04461	BP64T4063



Table 48 QUAD-RING® Seal and Back-up Ring (cut) Ordering Information for Reciprocating Piston Sealing (Imperial- Continued)

Bore Diameter B H9	Groove Diameter A h9	Groove Width (+ .008)			QUAD-RING® Seal	Spiral Back-up Ring
		G	G1	G2	Part Number	Part Number
17.000	16.494	.310	.409	.507	QRAR04462	BP64T4190
17.500	16.994	.310	.409	.507	QRAR04463	BP64T4317
18.000	17.494	.310	.409	.507	QRAR04464	BP64T4444
18.500	17.994	.310	.409	.507	QRAR04465	BP64T4571
19.000	18.494	.310	.409	.507	QRAR04466	BP64T4698
19.500	18.994	.310	.409	.507	QRAR04467	BP64T4825
20.000	19.495	.310	.409	.507	QRAR04468	BP64T4952

Ordering Example

QUAD-RING® Seal and Back-up Ring for bore diameter
 B = 100,0 mm
 Application: radial-dynamic, external sealing
 QUAD-RING® Seal according to AS 568A
 Dimensions: Inside diameter = 91,45 mm
 Cross section = 5,33 mm
 Compound: NBR 70
 (Acrylonitrile Butadiene Elastomer,
 70 Shore A)

Order No.	QRAR04342	-	N7004
Series No.			
Quality Index (Standard)			
Material code (Standard)			

Part No., QUAD-RING® Seal dimensions and installation dimensions see Tables 45-48 pages 150-159. Compounds, see Table 1, page 2

Ordering Example

Back-up Ring, type BP (spiral) fitted for QUAD-RING® Seal with cross section of 5,33 mm and bore diameter
 B = 100,00 mm
 Compound: PTFE (Polytetrafluorethylene)

Order No.	BP4900902	-	PT00
Series No.			
Quality Index (Standard)			
Material code (Standard)			

Part No. and installation dimensions see Tables 45-48 on pages 150-159
 Standard compound PTFE
 Further indications about Back-up Rings see Back-up Ring catalog.



■ General

Wear rings have the task of precisely guiding the piston and the piston rod of a working cylinder and absorbing the lateral forces which occur. At the same time, metallic contact between the sliding parts of the cylinder, e.g. piston and cylinder barrel or rod and cylinder head, must be prevented. Nonmetallic wear rings offer major benefits compared with metallic guides.

Advantages

- Avoids metal to metal contact
- High load bearing strength
- Compensate edge forces
- Very wear-resistant, long service life
- Low friction behavior
- Damping of mechanical vibrations
- Good wiping effect, embedding of foreign particles possible
- Protect the seal against "dieseling"
- Reacts to side load forces
- Prevents hydrodynamic problems in the guide system
- Simple closed groove, easy installation
- Low service costs
- Increases "E" gap with seal by centering the element

Designs

In view of the different specific demands made on piston and rod guides, two wear ring materials are available:

Turcite® T47

Recommended material for low friction, stick slip free movements. It has exceptionally high wear resistance properties and a very high resistance to heat and chemicals.

Luytex® C380

A fabric composite material made of fine plastic mesh with lubricant additives impregnated with special hot curing polymer resins. It dampens vibrations, has a very high resistance to wear and good dry running properties. The color is bluish green.

In principle, piston wear rings and rod wear rings are interchangeable if the difference in size is taken into consideration, e.g. piston wear ring, diameter 100mm x 2,5mm thick can be used as a rod wear ring with a diameter 95mm x 2,5 mm thick. Depending on the material and dimensions of the wear ring, the thickness tolerance is +0 to -0,08mm.

Fields of Application

Turcite® T47

Velocity: up to 15 m/s (50 ft/s) reciprocating
 Temperature: -60°C to +200°C (-76°F to 392°F)
 Dynamic Compressive Strength: max. 15 N/mm² at 60°C.

With the thermoplastic Turcite® materials, it must be taken into account that the surface pressure decreases with increasing temperatures. The load bearing ability for dynamic applications in practice is dependent primarily on the operating temperature; this should therefore generally not exceed 150°C (302°F).

Luytex® C380

Velocity: up to 1m/s (3 ft/s) reciprocating
 Temperature: -50°C to +130°C (-58°F to 266°F)
 Dynamic Compressive Strength: max. 90 N/mm² at 60°C.

The permissible load bearing ability for dynamic applications in practice is dependent i.e. on the operating temperature; it should generally not exceed 100°C (212°F).

Z-Gap Calculations

Rod: .050 (Ø C+w)

Bore: .050 (Ø B-w)

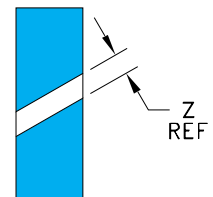

Cut Lengths For Rod

L=3,092 (Ø C+w) max

(Series GR for Rod)

Ø C = Rod Diameter

w = guide ring thickness



Cut Lengths For Bore:

$L = 3,092 (\varnothing B - w)$ max

(Series GP for Bore)

$\varnothing B$ = Bore Diameter w = guide ring thickness

Type of Cut

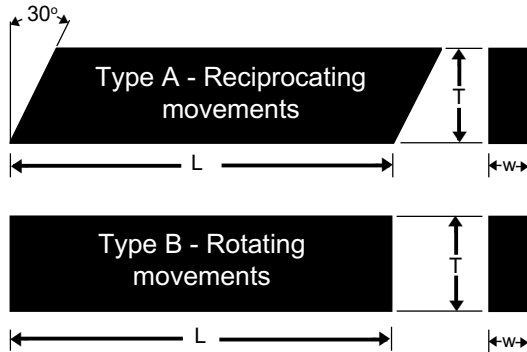

Dimensioning of Guide Rings

In order to determine the necessary guide ring area, it is crucial to utilize the elastic deformation. Radial guide ring play, which is caused by dimensional tolerances, deformation and wear, must be smaller than the smallest seal gap in the system. The deformation values under load for various materials can be determined by the diagrams in Figure 44 and Figure 45. Calculations for specific applications can be provided upon request.

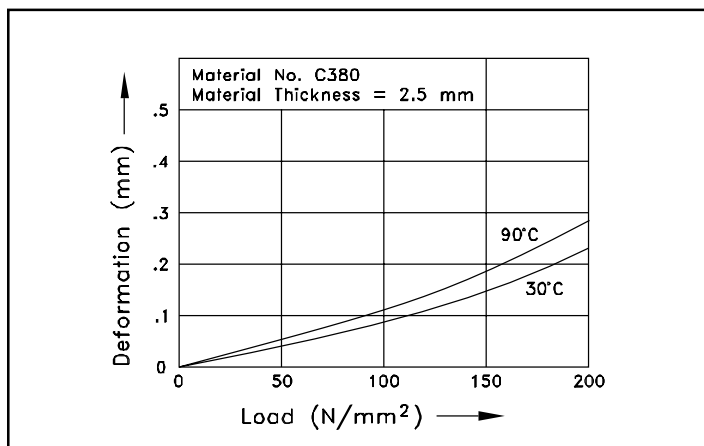

Figure 44 Deformation graph: Luytex® C380

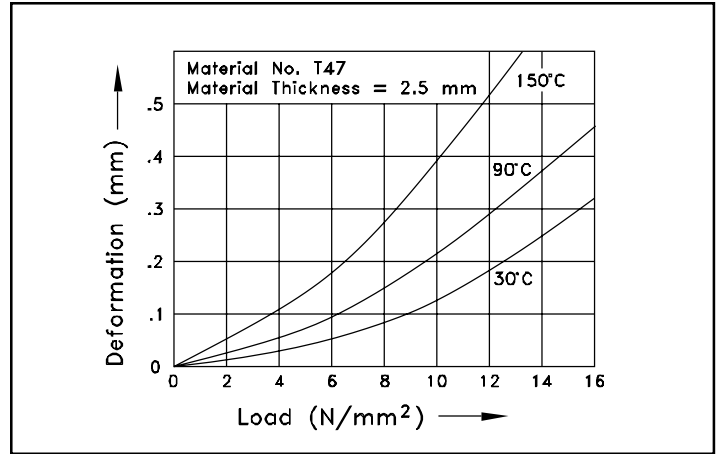

Figure 45 Deformation graph: Turcite® T47

An initial determination for the required number and width of guide rings can be determined from the following formula:

$$T = \frac{F \times f}{C \times P_r}$$

- where: T = guide ring width
 F = Maximum radial load (N)
 f = Safety factor
 C = Rod diameter (mm)
 P_r = Dynamic compressive strength

example:

- C = 60mm
 F = 40.000 N
 t = 60°C
 f = 2
 P_r = 90 N/mm²
 Guide Ring material = Luytex® C380

$$T = \frac{40.000 \times 2}{60 \times 90} = 14,8 \text{ mm}$$

We can select either one (1) guide ring that has a 15mm width, or two guide rings with 9,7 mm width each. We would recommend the installation of two 9,7 mm wide guide rings in order to give a greater combined guide ring width. The selection of two series GR69 guide rings with a groove width of 9,7mm will consequently increase the safety factor to 2,6.



Wear Ring Dimensional Data Piston

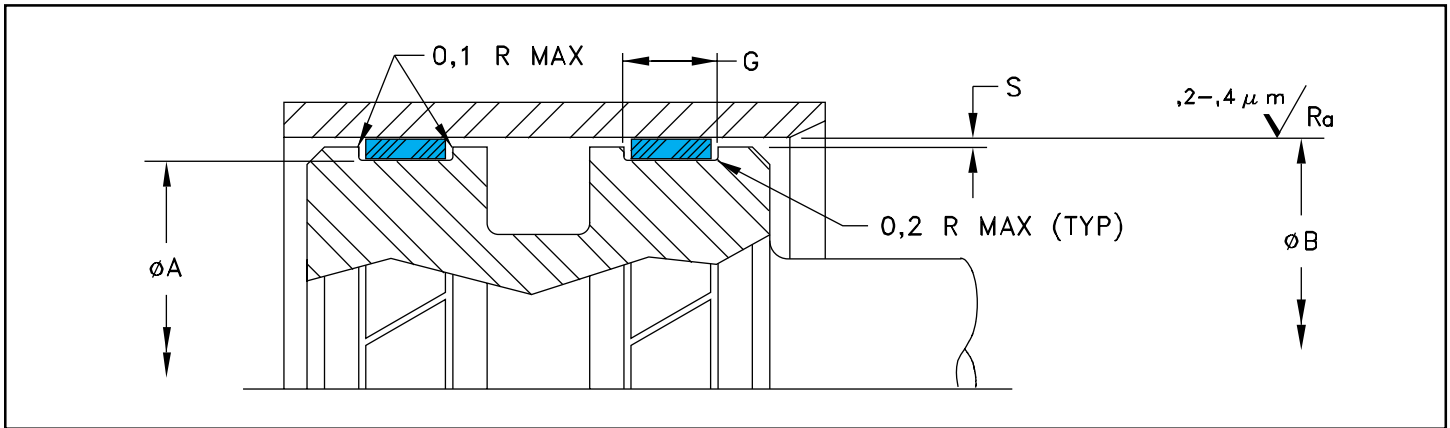

Table 49 Wear Ring Ordering Information Piston (Metric)

Series No.	Bore Diameter B H9	Groove Diameter A h8	Groove Width G+0,2	Radial Clearance S
GP65	16-140,0	B - 5,00	5,60	0,25-0,50
GP69	60-220,0	B - 5,00	9,70	0,25-0,70
GP73	130-400,0	B - 5,00	15,00	0,25-0,90

Series No.	Bore Diameter B H9	Groove Diameter A h8	Groove Width G+0,2	Radial Clearance S
GP75	320-999,9	B - 5,00	25,00	0,25-1,10
GP99	100-999,9	B - 8,00	9,70	0,25-1,50

Wear Ring Dimensional Data Rod

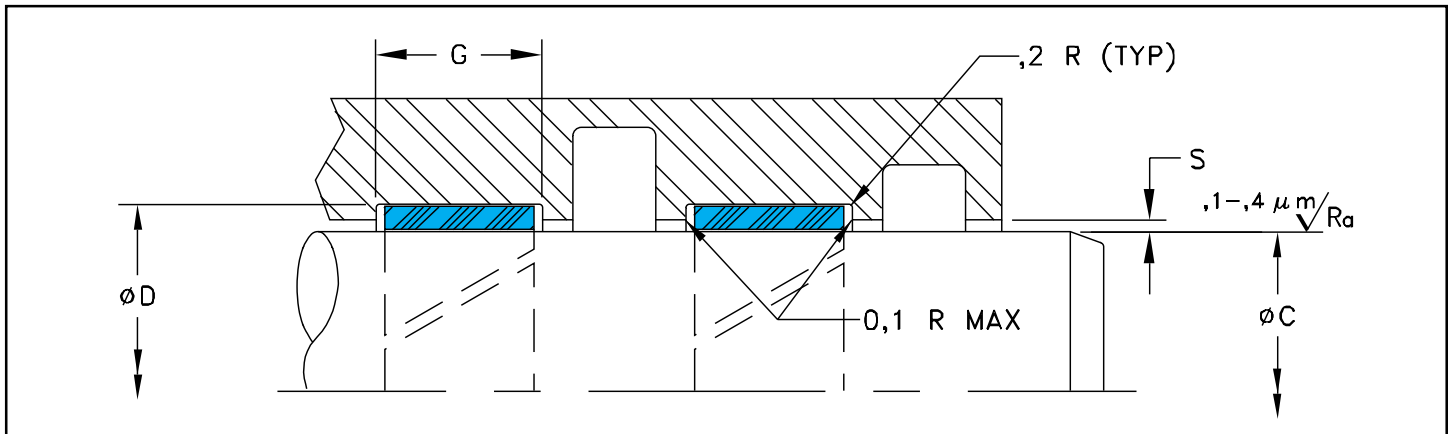

Table 50 Wear Ring Ordering Information Rod (Metric)

Series No.	Rod Diameter C f8	Groove Diameter D H8	Groove Width G+0,2	Radial Clearance S
GR65	15-140,0	C + 5,00	5,60	0,25-0,50
GR69	32-220,0	C + 5,00	9,70	0,25-0,70
GR73	80-400,0	C + 5,00	15,00	0,25-0,90

Series No.	Rod Diameter C f8	Groove Diameter D H8	Groove Width G+0,2	Radial Clearance S
GR75	200-999,9	C + 5,00	25,00	0,25-1,10
GR99	100-999,9	C + 8,00	9,70	0,25-1,50



Ordering Example

Ring:

Guide Ring for Piston

Diameter B: 100,00 mm
 Series number: GP69 (see Table 49)
 Groove width: 9,70 mm
 Thickness: 2,50 mm
 Material: Turcite® T47 (see page 2)
 Standard Type: With scarf cut and teardrop texture

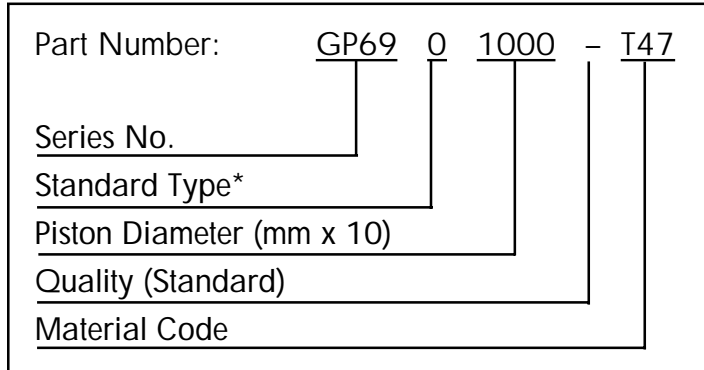

* without teardrop use "L"
 for rotating motion, use "B" for sizes ≥ 100 mm
 for rotating motion, use "D" for sizes < 100 mm

Table 51 Bulk Ordering Information

When ordering bulk material, refer to the following table:

Part Number	Width (mm)	Material Code	Length (meter)	Thickness (mm)
GM6500000-T47	5,60	T47	13,5	2,50
GM6900000-T47	9,70	T47	13,5	2,50
GM7300000-T47	15,00	T47	13,5	2,50
GM7500000-T47	25,00	T47	13,5	2,50
GM9900000-T47	9,70	T47	9,5	4,00
GM65A0000-C380	5,60	C380	2,00	2,50
GM69A0000-C380	9,70	C380	2,00	2,50
GM73A0000-C380	15,00	C380	2,00	2,50
GM75A0000-C380	25,00	C380	2,00	2,50



Installation Instructions

Before you begin:

- It is essential that the cylinder and piston rod are chamfered.
- Sharp edges must be deburred and filleted or chamfered.
- The crests of threads must be covered.
- Any dust, splinters or other foreign particles must be carefully removed.
- Do not use tools with sharp edges.
- Before assembly, the cylinder, piston rod and seals must be oiled or greased.
- Turcon® rings can be expanded easily (and recover their shape afterwards) if they are heated to about 80 to 120°C in oil or water.
- If grease is used for lubrication, it must not contain any solid additives (e.g., molybdenum disulfide or zinc sulfide). The grease should be compatible with the elastomer.

Rod Seal (I.D.) Installation Data

The following installation procedure is for a rod seal such as the Turcon® Stepseal® K, U-Cup, DA 17, etc. An installation tool is recommended, as shown in Figure 46, for one piece glands.

- Step 1: Clean and lubricate all gland hardware, seal components and sizing rod (as noted above).
- Step 2: Place rubber (elastomer) into gland assembly.
- Step 3: Collapse Turcon® seal ring as shown in Figure 46, taking care not to crease the Turcon® seal ring. Place into gland assembly as shown in Figure 46. If possible, use fingers to smooth out I.D. of Turcon® seal ring after installation.
- Step 4: Push while twisting the resizing tool into the bore. Remove the resizing tool from the bore after one minute.

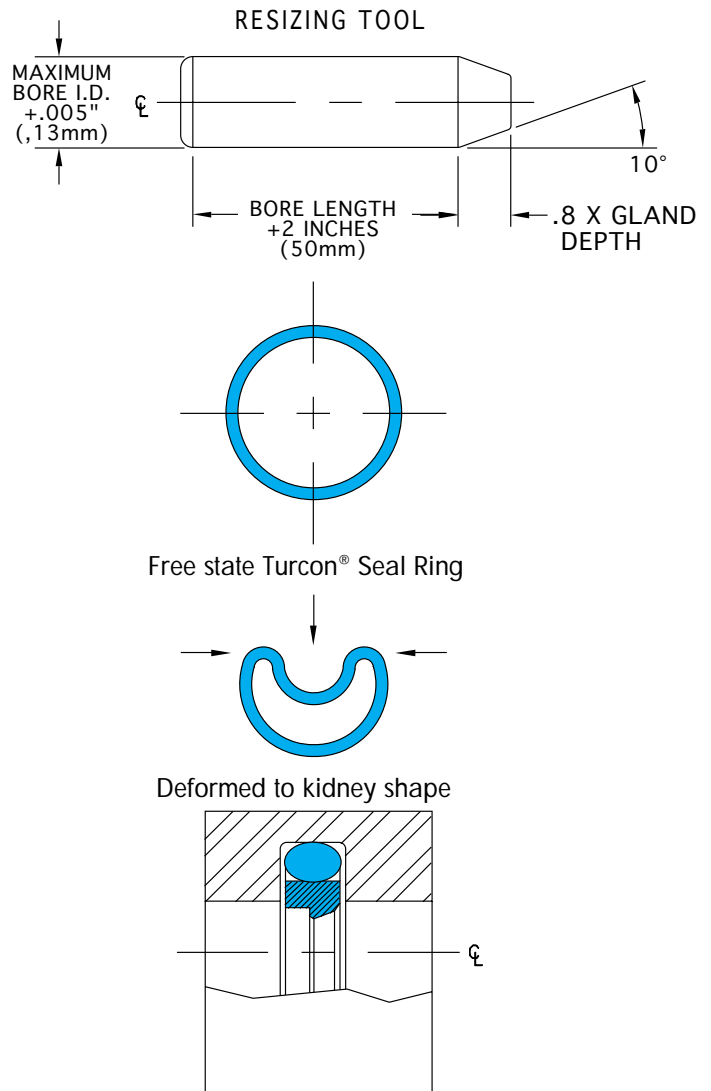

Figure 46 Rod Installation sequence



Piston Seal (O.D.) Installation Data

The following installation procedure is for a piston seal, such as the Turcon® CST™ Seal, Turcon® Glyd Ring® T, etc. Installation tools, as shown in Figure 47 are recommended for one piece glands.

- Step 1: Clean and lubricate all gland hardware, seal components as outlined above.
- Step 2: Place rubber (elastomer) into gland assembly as shown in Figure 47.
- Step 3: Place loading mandrel onto piston.
- Step 4: Place Turcon® seal ring on loading mandrel as shown in Figure 47.
- Step 5: Push Turcon® seal ring up the loading mandrel and into the gland .
- Step 6: Remove the loading mandrel from the piston.
- Step 7: Push, while twisting, the resizing tool onto the seal assembly. Remove after one minute.

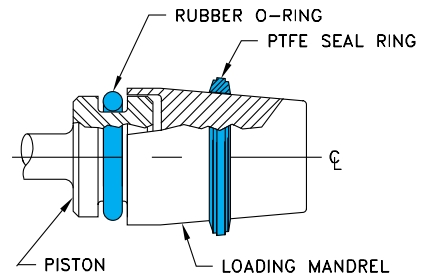
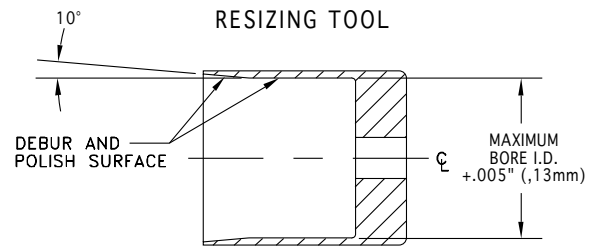
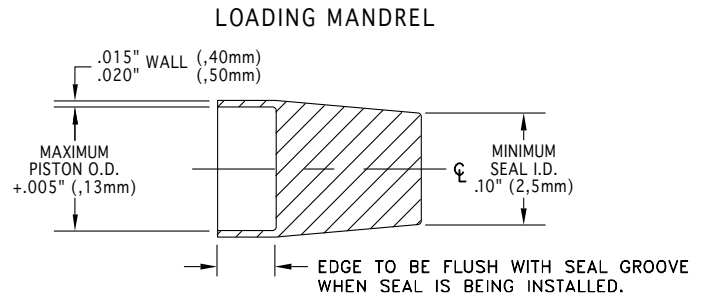

Figure 47 Piston installation



Quality Criteria

The cost-effective use of seals and bearings is highly influenced by the quality criteria applied in production. Seals and bearings manufactured by Busak+Shamban are continuously monitored according to strict quality standards from material acquisition through to delivery.

Certification of our production plants in accordance with international standards EN ISO 9000 meets the specific requirements for quality control and management of purchasing, production and marketing functions.

Our quality policy is consistently controlled by strict procedures and guidelines which are implemented within all strategic areas of the company.

All testing of materials and products is performed in accordance with accepted test standards and specifications, e.g. random sample testing in accordance with DIN ISO 2859 part 1/ANSI/ASQC Z 1.4-1993/MIL-STD- 105 E. Inspection specifications correspond to standards applicable to individual product groups (e.g. for O-Rings: ISO 3601/DIN 3771).

Our sealing materials are produced free of chlorofluorinated hydrocarbons and carcinogenic elements.

The 10th digit of our article number defines the quality characteristics of the part. A hyphen indicates compliance with standard quality criteria outlined in this catalog. Customer-specific requirements are indicated by a different symbol in this position. Customers who require special quality criteria should contact their local Busak+Shamban sales office for assistance. We have experience to meet all customer quality requirements.

Storage

(The notes in italics only apply to elastomeric sealing materials).

Seals and bearings are often stored as spare parts for prolonged periods. With a few simple precautions, the shelf life of these products can be considerably lengthened.

Seals and bearings should be stored where they are safe from damage by external influences. Deformation, in particular, should be avoided during storage.

Under the influence of various external factors e.g. heat, moisture, light, oxygen, ozone and as a result of contact with liquid media,

the properties of certain materials may change. For example, deformation, aging and weathering can cause deterioration of the original mechanical and physical properties, depending on the material and shape of the parts.

Fundamental instructions on storage, cleaning and maintenance of elastomer seal elements are described in international standards, such as:

Storage of rubber products: DIN 7716/BS 3F68:1977

*Maximum age limitation: MIL-HDBK-695C or
MIL-STD-1523A or
DIN 9088*

The individual guidelines give several recommendations for the shelf life of elastomers, depending on the material classes.

The following guidelines should be observed to maintain the optimum physical and chemical values of the parts:

Heat

The ideal temperature for storage is between +5°C/41°F and +25°C/77°F. Direct contact with heaters should be avoided.

Moisture

Parts may be stored dry under normal atmospheric conditions (65% rel. moisture ± 10).

Weathering

To protect them against damage, seals and bearings should be kept in the original packaging or in airtight containers.

Ozone

Destruction of certain elastomeric sealing materials due to ozone can be caused by the following machines and equipment:

- Mercury discharge lamps
- High voltage equipment
- Electric motors
- Electric spark sources or discharges



Cleaning

Cleaning with soap and water is generally the least harmful; however, this method should not be used for polyurethane rubbers or fabric composites with exposed fabric.

Organic solvents, abrasives and sharp objects should not be used. Articles that have been cleaned should be dried at room temperature.

Conversion Tables

SI - Basic Units

Measures	Units	Symbol
Length	Meter	m
Mass	Kilogram	kg
Time	Second	s
Electric current	Ampere	A
Temperature	Kelvin	K
Luminous intensity	Candela	cd
Amount of substance	Mol	mol

Length

	inch	foot	yard	mm	meter
1 inch =		0.0833	0.0278	25.4	0.0254
1 foot =	12		0.333	304.8	0.3048
1 yard =	36	3		914.4	0.9144
1 mm =	0.03937	0.0033	0.00109		0.001
1 meter =	39.37	3.2808	1.0936	1,000	

Torque

	inch-ounce	inch-pound	foot-pound	kg-meter	Newton-meter
1 inch-ounce =		0.0625	0.0052	7.2×10^{-4}	7.06×10^{-3}
1 inch-pound =	16		0.0833	1.152×10^{-2}	0.1130
1 foot-pound =	192	12		0.1383	1.356
1 kg-meter =	1,388.7	86.796	7.233		9.80665
1 Newton-meter =	141.6	8.850	0.7375	0.1020	

Area

	inch ²	foot ²	yard ²	mm ²	m ²
1 inch ² =		0.0069	0.00077	645.16	6.45×10^{-4}
1 foot ² =	144		0.111	92,903	0.0929
1 yard ² =	1,296	9		836,100	0.8361
1 mm ² =	0.0016	1.0764×10^{-5}	1.196×10^{-5}		10^{-6}
1 m ² =	1,550	10.764	1.196	10^6	

Volume

	inch ³	US quart	imp. gallon	foot ³	US gallon	liter
1 inch ³ =		0.0173	0.0036	0.00058	0.0043	0.0164
1 US quart =	57.75		0.2082	0.0334	0.25	0.9464
1 imp. gallon =	277	4.8		0.1604	1.2	4.546
1 foot ³ =	1,728	29.922	6.23		7.48	28.317
1 US gallon =	231	4	0.8327	0.1337		3.785
1 liter =	61.024	1.0567	0.220	0.0353	0.264	

Pressure

	inch Hg	psi	atmosphere	torr	mm Hg	bar	MPa	kg/cm ²
1 inch Hg =		0.491	0.0334	25.4	25.4	0.0339	0.00339	0.0345
1 psi =	2.036		0.0680	51.715	51.715	0.0689	0.00689	0.0703
1 atmosphere =	29.921	14.696		760	760	1.0133	0.10133	1.0332
1 torr =	0.0394	0.0193	0.0013		1	0.0013	0.00013	0.00136
1 mm Hg =	0.0394	0.0193	0.0013	1		0.0013	0.00013	0.00136
1 bar =	29.53	14.504	0.987	749.87	749.87		0.1	1.020
1 MPa =	295.3	145.04	9.869	7498.7	7498.7	10		10.2
1 kg/cm ² =	28.950	14.22	0.968	735.35	735.35	0.980	0.098	

Temperature

	Kelvin	°C	°F
1 Kelvin =		K - 273.15	K 9/5 - 459.67
1 °C =	°C + 273.15		°C 9/5 + 32
1 °F =	$5/9 (°F - 32) + 273.15$	$(°F - 32) \times 5/9$	

Density

	ounce/inch ³	pound/foot ³	g/cm ³
1 ounce/inch ³ =		108	1.73
1 pound/foot ³ =	0.0092		0.016
1 g/cm ³ =	0.578	62.43	

Force

	Newton (N)	kilopond (kp)	pound force
1 Newton (N) =		0.10197	0.22481
1 kilopond (kp) =	9.80665		2.20463
1 pound force =	4.4482	0.45359	

Velocity (Speed)

	foot/s	foot/min	mile/hour	meter/s	km/hour
1 foot/s =		60	0.6818	0.3048	1.097
1 foot/min =	0.017		0.0114	0.00508	0.01829
1 mile/hour =	1.4667	88		0.447	1.609
1 meter/s =	3.280	196.848	2.237		3.6
1 km/hour =	0.9113	54.68	0.6214	0.278	

Mass

	ounce	pound	kg
1 ounce =		0.0625	0.0283
1 pound =	16		0.4536
1 kg =	35.274	2.2046	

Engineering Action Request



Note: Only information provided in this EAR will be considered for the recommended solution

Prepared By: Application Engr:
 Date Prepared: Sales Engr:
 Answers Required By: Inside Sales: B+S MC EAR No.:
 Mfg. Project No.:

CUSTOMER

Name Contact
 Address Phone x
 Customer No Fax
 MS Code Email

APPLICATION DESCRIPTION

Equipment:
 Component:
 Problem:
 Current Seal:

System Type
 Rod
 Piston
 System (rod + piston)
 Shaft
 Face

Product
 Seal
 Wiper
 Bearing
 Other
 New Design

Motion
 Static
 Reciprocating
 Rotary
 Oscillatory

Pressure
 Unidirectional
 Bi-directional
 Pulsating
 Without Pressure

Demand/Year: Price: @ Pcs.
 Quote Qty: Target: @ Pcs.

OPERATING CONDITIONS

	Units	Minimum	Operating	Maximum
Media to Seal:	Temperature			
	Pressure			
Other Media:	Vacuum			
	Stroke			
Contamination:	Cycle-Rate			
	Angle of Rotation			
	RPM			
	Velocity			
	Side Load			

PERFORMANCE PRIORITY

Most critical: Units Value Units

Planning Test? No Yes

Expected Life:	Units	Value	Friction:	Units	Breakout	Dynamic
Max Leakage:			Torque:			

HARDWARE

Units Inch Metric Type Split Open Solid Stepped Recommend

	Nominal dim.	Tolerance	Change OK	Material	Finish	Hardness	Coating/Treatment
Rod Diameter:			<input type="checkbox"/>				
Bore Diameter:			<input type="checkbox"/>				
Rod Bore:			<input type="checkbox"/>				
Piston Diameter:			<input type="checkbox"/>				
Gland/Groove Width:			<input type="checkbox"/>				
Gland Depth:			<input type="checkbox"/>				
Groove Diameter:			<input type="checkbox"/>				
Extrusion Gap:			<input type="checkbox"/>				
Runout (TIR):			<input type="checkbox"/>				
Step Height:			<input type="checkbox"/>				
Bearing length:			<input type="checkbox"/>				

Notes:

Solution Proposed to customer by MC:

MIL-G-5514 Dash: AS 4716 Dash: B/U Width:

Required: Installation Dwg Inspection Dwg Quote Prototype Qty:
 Other Production Qty:
 Date Proto's Required:

Further details on additional page(s):

SPECIFICATIONS : QUALITY CHARACTERISTICS: ENCLOSURES: ADDITIONAL INFORMATION:

Engineering Action Request

Prepared By:	<input type="text"/>	Application Engr:	<input type="text"/>	B+S MC EAR No.:	<input type="text"/>
Date Prepared:	<input type="text"/>	Sales Engr:	<input type="text"/>	Mfg. Project No.:	<input type="text"/>
Answers Required By:	<input type="text"/>	Inside Sales:	<input type="text"/>		

SPECIFICATIONS

Automatic installation?	No <input type="checkbox"/> Yes <input type="checkbox"/>	Spec.	<input type="text"/>
Existing customer spec?	No <input type="checkbox"/> Yes <input type="checkbox"/>	Ref.	<input type="text"/>
Existing customer product drawing?	No <input type="checkbox"/> Yes <input type="checkbox"/>	Ref.	<input type="text"/>
Existing customer material spec?	No <input type="checkbox"/> Yes <input type="checkbox"/>	Ref.	<input type="text"/>

Other requirements:

QUALITY CHARACTERISTICS

Inspection level

According to B+S Specification:

Special Request:

(e.g. for O Ring, AQL1.0 for surface defects acc. ISO 3601/3 grade N)

Existing inspection plan?	No <input type="checkbox"/> Yes <input type="checkbox"/>	Ref.	<input type="text"/>
Certificate required?	No <input type="checkbox"/> Yes <input type="checkbox"/>	Ref.	<input type="text"/>
Additional Quality guidelines?	No <input type="checkbox"/> Yes <input type="checkbox"/>	Ref.	<input type="text"/>

ENCLOSURES

<input type="text"/>	Pages – specifications	<input type="text"/>	Samples
<input type="text"/>	Drawings	<input type="text"/>	Others

ADDITIONAL INFORMATION

Referring to:

Service Performance (friction, leakage, shelf life, ext/int pollution, etc.):

Use (frequency, cycles, exposure time, etc.)

Logistic / Packaging:

Sketch/Drawing:



Australia

Busak+Shamban
Level 23, HWT Tower
40 City Road
Southgate 3006 Australia
Phone ++03 9674 0444
Telefax ++03 9674 0400

Brazil

Busak+Shamban Ltda.
Av. Dr. Renato de Andrade Maia,
220
CEP 07114-000, Guarulhos – SP
Brasil
Phone ++55-11 6440-5109
Telefax ++55-11 6461-0194

Canada

TISPP CANADA
43 Voyager Court North
Etobicoke, Ontario
Canada M9W4Y6
Phone: ++416 213 9444
Telefax: ++416 213 9462

China/Hong Kong

Busak+Shamban Hong Kong
TISPP ASIA PACIFIC
9th Floor, Flat A
Cameron Plaza
23-25A Cameron Road
Tsim Sha Tsui, Kowloon
Hong Kong
Phone ++852 2366 9165 or 9167
Telefax ++852 2366 7471

Hong Kong

Wai Ching Ltd.
Unit 13, 3/F
Laurels Industrial Center
32 Tai Yau Street
San Po Kong, Kowloon
Hong Kong
Phone ++852 2326 9368
Telefax ++852 2752 7602

China

Busak+Shamban China
TISPP (EC) Shanghai
Room 506, Changning Equatorial
Serviced Apartments
No. 889 Changning Road
Changning District
Shanghai, 200050 PR China
Phone ++86 21 6210 5023
Telefax ++86 21 6210 8027

China

Busak+Shamban China
TISPP (NC) Dalian
Room 1606, 16/F
Dong Ya Bank Mansion, No.
10 TongXing Street
Zhong Shan District
Dalian 116001 PR China
Phone ++86 411 280 94572
Telefax ++86 411 280 5692

Busak+Shamban China

TISPP (WC) Wuhan
Flat B-1, 13/F, Credit
Cooperative Building
No. 618 JianShe Road
Hankou, 430015 Wuhan
PR China
Phone ++86 27 8549 7022
Telefax ++86 27 8556 0273

Japan

Busak+Shamban KK
Nittochi Oshiage Bldg., 5F
3-14-4 Narihira 3-chome
Sumida-ku
Tokyo 130-0002 Japan
Phone ++81 35 610 1811
Telefax ++81 35 610 1809

India

Busak+Shamban
Seals & Bearings Pvt. Ltd.
No. 27, 32nd Cross
7th Block, Jayanagar
Bangalore 560 082 India
Phone ++91 80 6555 157
Telefax ++91 80 6555 153

India

Rollon Hydraulics
Old No. 16A, New No. 27
32nd Cross, 7th Block
Jayanagar
Bangalore 560 082 India
Phone ++91 80 6555 157
Telefax ++91 80 6555 153

Indonesia

Busak+Shamban
Indonesia
Representative Office
Jl. Johar No. 2, 3rd Floor
Menteng, Jakarta 10340
Indonesia
Phone ++62 21 829 5391
Telefax ++62 21 829 5391

Korea

Hansung Sangsa Co., Ltd.
360-3 Dang Jeong-Dong
Koonpo-Si Kyunggi-Do
South Korea
Phone ++82 343 455 0660
Telefax ++82 31 455 1818

Mexico

TI GROUP
SPECIALTY POLYMER
PRODUCTS
Poniente 152 #679
Col. Ind. Vallejo
Mexico, D.F. 02300
Phone ++525 567 1143
Telefax ++525 567 6590

Pakistan

JJ Hydraulic Pneumatic
Systems (PVT.) LTD.
Room #127, 1st Floor
Hotel Metropole Building
Club Road
Karachi-75520 Pakistan
Phone ++92 21 566 1063
Telefax ++92 21 566 1063

Singapore

Busak+Shamban Pte. Ltd.
70 Bendemeer Road
#06-01 Hiap Huat House
Singapore 339940
Phone ++65 293 2500
Telefax ++65 293 0030

Taiwan

Busak+Shamban Taiwan
No. 21, Fu-An 5th Street,
Taichung 40750, Taiwan
Phone ++886 4 2358 0082
Telefax ++886 4 2358 0083

USA

TISPP West
3904 Del Amo Blvd., #805
Torrance, California 90503
Phone: ++(310) 371 1025
Telefax: ++(310) 371 3135

TISPP Midwest

270 Tubeway Drive
Carol Stream, Illinois 60188
Phone: ++(630) 682 8855
Telefax: ++(630) 682 3860

TISPP Southwest

10801 Hamerly, #246
Houston, Texas 77043
Phone: ++(713) 461 3495
Telefax: ++(713) 461 1677

TISPP Central

2531 Bremer Drive
Fort Wayne, Indiana 46803
Phone: ++(219) 748 5704
Telefax: ++(219) 749 4844

TISPP South

4275 Arco Lane
North Charleston,
South Carolina 29418
Phone: ++(843) 747 7656
Telefax: ++(843) 747 7916

PRODUCT RANGE



Precision O-Rings made of Elastomers, Polyurethane, PTFE, Kalrez®, Zalak®



FEP O-Ring



QUAD-RING® Seal



Kantseal



Back-up Ring



Back-up Ring Concave



Turcon® Glyd Ring® T



Turcon® CST™ Seal



Turcon® AQ-Seal® 5



Zurcon® Wynseal



D-A-S Compact Seal



Turcon® Double Delta®



Turcon® Stepseal® K



Zurcon® Rimseal



Zurcon® L-Cup



U-Cup



Turcon® Excluder®



Rod Scraper DA 22



Rod Scraper DA 17



Rod Scraper ASW



Rod Scraper SA



Rod Scraper A



Metal Scraper



Turcite® Luytex® and Zurcon® Wear Rings



Complete Pneumatic Piston PK



Turcon® Roto Glyd Ring®



Radial Oil Seal



Shaft Repair Kit



Varilip®



V-Seal



Axial Shaft Seal



Heavy Duty Seal



Wills Rings®



Airseal



U-Seal



Turcon® Variseal™ M2



Turcon® Variseal™ HF



Turcon® Roto Variseal™



Turcon® Variseal™ W



Turcite® -B Slydway®



Bearing Brushes



Custom made Components



Installation Tools



O-Ring
QUAD-RING® Seal
Kantseal





Contents

Description	2
Quality criteria	3
Materials	6
Design Instructions	7
Installation Instructions	9
Installation Recommendations	10



The information in this brochure is based on many decades of experience in the manufacture and application of sealing and bearing systems. However, unknown parameters and conditions may restrict general statements during usage. It is vital that customers satisfy themselves as to the suitability of individual products through adequate testing. For this reason, and due to the wide range of applications of our products, Busak + Shamban can accept no liability as to the suitability or correctness of our recommendations in individual cases.

The application limits for pressure, temperature and speed given in this catalogue are maximum values determined in the laboratory. During practical applications it should be remembered that due to the interaction of the operating parameters, the maximum values must be set correspondingly lower. For exceptional operating conditions, please contact your Busak+Shamban representative.

This edition supersedes all previous brochures.

© Busak+Shamban 2000. All rights reserved.

® All registered trademarks. The turquoise colour is a trademark for B+S products.
This brochure, or any part thereof, may not be reproduced without our permission.



■ Description

Standard radial shaft seals have only a limited application range with respect to pressure, temperature and media loads due to their elastomer sealing lip. Furthermore they only have a limited suitability for applications with inadequate lubrication.

Varilip® shaft seals from Busak+Shamban extend this application range by using modern Turcon® materials developed specially for rotational applications.

They are characterised in particular by the low friction and their stick-slip-free running, thus reducing the heat development and permitting higher peripheral speeds.

The Varilip® shaft seal is dimensionally interchangeable with the shaft seals to DIN 3760 and ISO 6194/1.

The minimal groove size required for Varilip® allows its use as a pressurised seal where the installation of a mechanical shaft seal would not be possible due to constructional reasons.

Characteristics

In contrast to the conventional shaft seals, the Varilip® seal requires no metallic energising spring.

As can be seen from Figure 1, dynamic sealing is effected by the radial load of the sealing lip against the shaft. Static sealing is effected on the one hand by a press fit of the metallic casing in the housing bore and, on the other, by an elastomeric flat gasket between metallic housing and Turcon® sealing lip.

Varilip®, Type A

Type A is a one-lip seal suitable for use in standard industrial applications up to $p_{max} = 0.5 \text{ MPa}$ (5 bar) where a radial shaft seal would be unable to withstand the temperature, friction, medium or poor lubrication. Type A allows high-speed shafts with peripheral speeds of up to 40 m/s to be sealed.

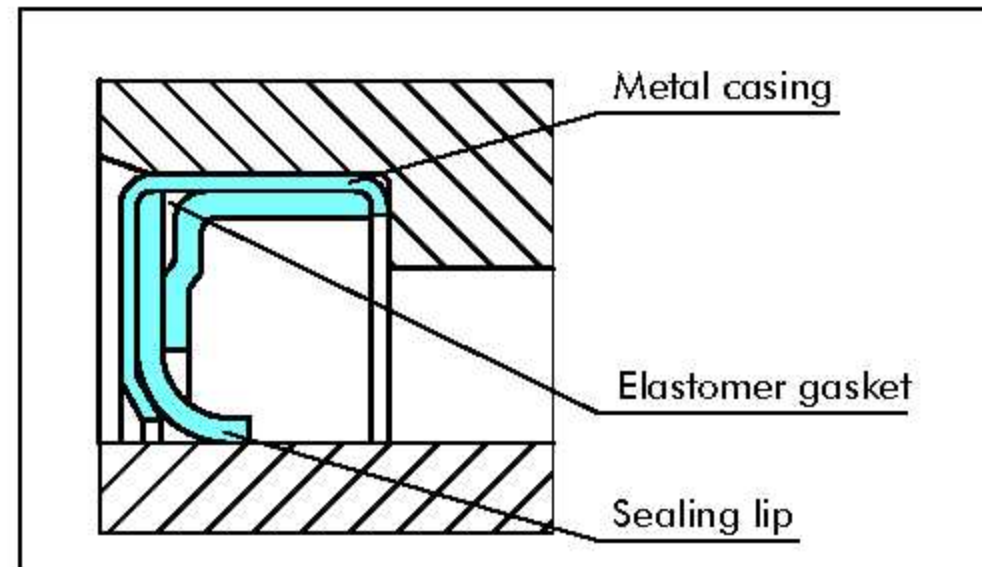

Figure 1 Type A

Varilip®, Type B

Type B is the preferred choice for applications in which a high sealability is demanded or where contaminated media are to be sealed. This two-lip type offers greater safety than the Type A.

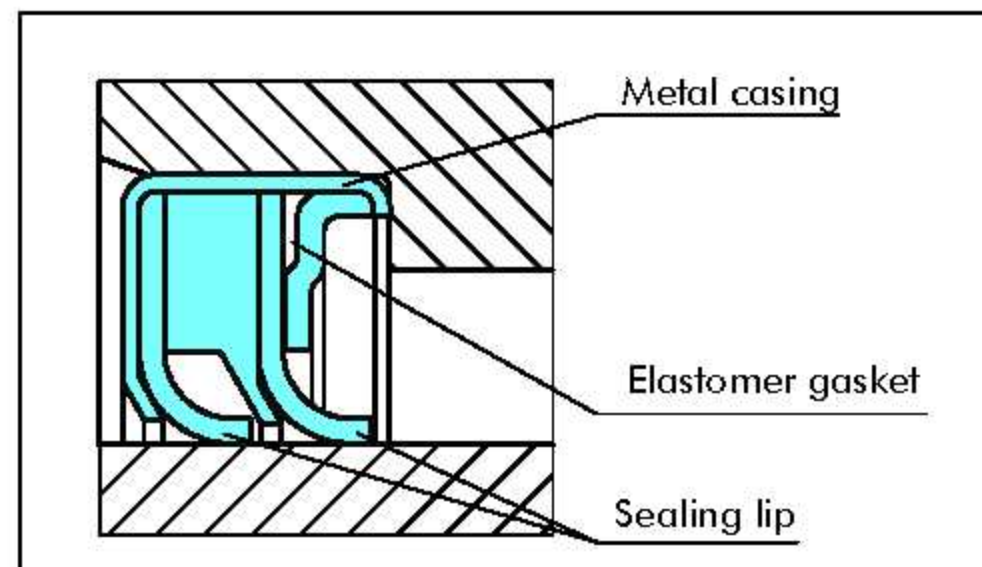

Figure 2 Type B



Varilip® , Type C

The Varilip® Type C can be used for applications involving higher pressures for which a simple elastomer radial shaft seal can no longer be considered. Due to a reinforcement of the sealing lip, pressures of up to 2 MPa (20 bar) are possible, e.g. as pump, shaft or rotor seals.

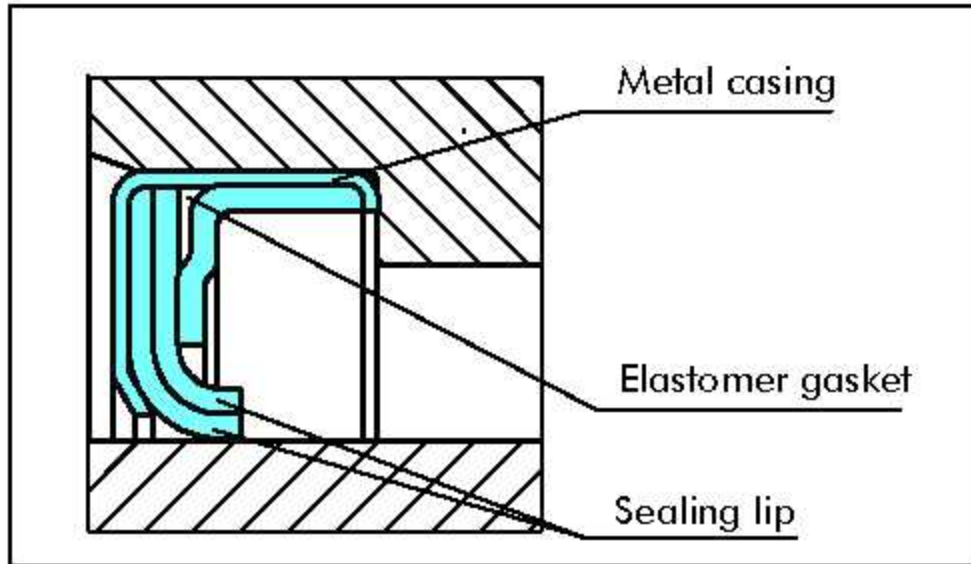

Figure 3 Type C

Varilip® , Type D

Whilst Types A to C can be used to seal against pressures from only one side, Type D can be subjected to pressure from both sides. Pressures of up to 0.1 MPa (1 bar) are permissible. The separation of two different media using a single seal is possible. The second lip can also take on the function of a wiper or dust lip. A grease packing between the sealing lips is recommended.

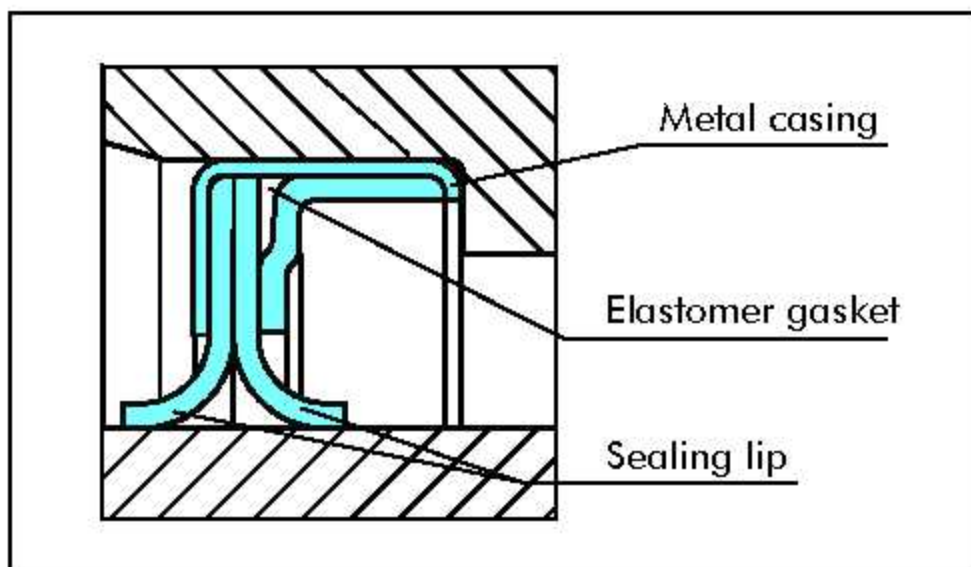

Figure 4 Type D

Table I summarises the important technical data and selection criteria for the different Varilip® types. Furthermore it gives an overview of the most significant applications in which the various Varilip® types have already proven themselves in practice.

This table is intended to allow the designer a quick preselection of the most favourable seal type and the optimum material for his specific application.

Further details and design and installation instructions for the different Varilip® types are given on pages 7 to 9. Information on materials and application limits of the various material combinations is given on page 6.

■ Quality Criteria

The cost-effective use of seals and bearings is highly influenced by the quality criteria applied in production. Seals and bearings manufactured by Busak+Shamban are continuously monitored according to strict quality standards from material acquisition through to delivery.

Certification of our production plants in accordance with international standards EN ISO 9000 meets the specific requirements for quality control and management of purchasing, production and marketing functions.

Our quality policy is consistently controlled by strict procedures and guidelines which are implemented within all strategic areas of the company.



All testing of materials and products is performed in accordance with accepted test standards and specifications, e.g. random sample testing in accordance with DIN ISO 2859 part 1/ANSI/ASQC Z 1.4-1993/MIL-STD- 105 E. Inspection specifications correspond to standards applicable to individual product groups (e.g. for O-Rings: ISO 3601/DIN 3771).

Our sealing materials are produced free of chlorofluorinated hydrocarbons and carcinogenic elements.

The 10th digit of our article number defines the quality characteristics of the part. A hyphen indicates compliance with standard quality criteria outlined in this catalogue. Customer-specific requirements are indicated by a different symbol in this position. Customers who require special quality criteria should contact their local Busak+Shamban sales office for assistance. We have experience to meet all customer quality requirements.



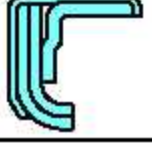
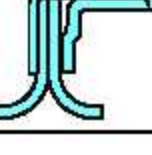
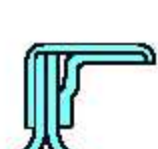

Table 1 Selection criteria for Varilip®

Seal Type	Application			Function	Material		Installation		Standard DIN/ISO	
	Field of application	light	medium		heavy	Lip material designation	Shaft surface hardness	Size range mm Ø		Groove type
Varilip® A 	Pumps Separators Compressors Crankshafts Hubs Fans Centrifuges	•	•	-	Single-acting	Turcon® T25 Turcon® T78	>55HRC >170 HB	6 - 170	Open casing	DIN 3760 ISO 6194/1
Varilip® B 	Machine tools Gearboxes Mixers Crankshafts	•	•	-	Single-acting	Turcon® T25 Turcon® T78	>55HRC >170 HB	6 - 170	Open casing	DIN 3760 ISO 6194/1
Varilip® C 	Pumps Machine tools Compressors	-	-	•	Single-acting	Turcon® T25 Turcon® T78	>55HRC >170 HB	6 - 170	Open casing	DIN 3760 ISO 6194/1
Varilip® D 	Separators Hubs Bearings Mixers	•	-	-	Double-acting	Turcon® T25 Turcon® T78	>55HRC >170 HB	6 - 170	Open casing	DIN 3760 ISO 6194/1

 Important selection criteria



Technical data			Technical behaviour				Seal
Pressure	Temperature range	Speed*	Friction	Medium compatibility	Dynamic sealing performance	Service life	Type
MPa (bar)	°C	m/s					
0.5 (5)	-60 to +200	40	A	A	B	B	Varilip [®] A 
0.5 (5)	-60 to +200	20	B	A	A	A	Varilip [®] B 
2.0 (20)	-60 to +200	20	C	A	B	A	Varilip [®] C 
0.1 (1)	-60 to +200	20	B	A	B	B	Varilip [®] D 

* See section "Application limits", on page 6

For special applications such as e.g. in vacuum operation, gas applications, etc., please contact Busak+Shamban.

A very good
B good
C satisfactory



Materials

An important factor for the proper function of rotational seals is the material. For this reason, Busak+Shamban has developed a range of specially modified materials for rotational applications on the basis of the proven Turcon® materials. Particular importance was attached to the optimisation of friction and wear properties, even at high peripheral speeds.

Figure 5 shows the standard materials used for Varilip® seals.

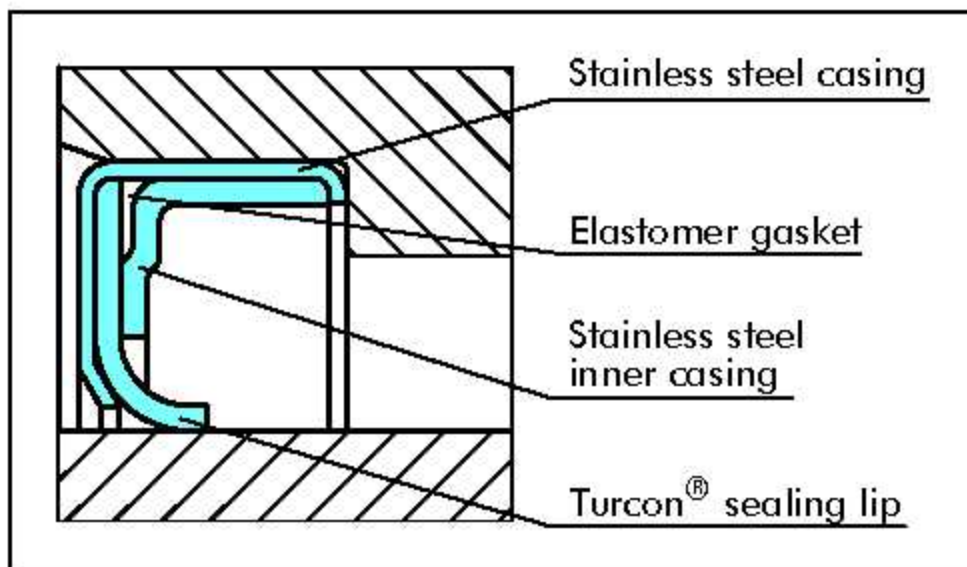

Figure 5 Materials for Varilip® seals

Two standard materials are available for the sealing lip:

Turcon® T25

This standard material with exceptional wear and friction characteristics is suitable for a large temperature range and is resistant to most media. Good results are achieved if the shaft surface has a minimum hardness of 55 HRC. It is generally well-suited to oxide ceramic surfaces produced by plasma coating.

At low pressures and speeds up to 4 m/s, a hardness of the mating surface of 45 HRC is sufficient.

Turcon® T78

This material is characterised by its particularly good running behaviour. This permits its use for dry running applications, applications with poor lubrication and in conjunction with soft shaft surfaces, e.g. in applications in the chemical industry when stainless steel has to be used as shaft material. The hardness of the mating surface should not be less than 170 HB.

Further information on the materials for seal casings and gaskets is contained in Tables II to IV.

Table II Material selection for sealing lip

Mating surface	Application limits	Material
> 55 HRC	Pressure < 2 MPa	Turcon® T25 Turcon® T78
> 170 HB	Pressure < 0.2 MPa	Turcon® T78

Table III Casing materials

Medium	Material	Material Code
Oils, greases, air/gases, water, vapour, solvents, foodstuffs	Stainless steel Material No. 1.4301 AISI 304	1
Acids, caustics, seawater	Acid-resistant stainless steel Material No. 1.4436 AISI 316	2
	Acid-resistant stainless steel Material No. 1.4571 AISI 316 Ti	3*)

*) Only for type A, C and D up to max. 90 mm outside diameter.

Table IV Materials for gasket elastomers

Medium	Temperature	Material	Code
Air, water, oils, greases	Nitrile-Elastomer - 30 to + 110°C	NBR	N
Air, water, vapour, foodstuffs, alcohols	Ethylene-propylene-elastomer - 60 to + 150°C	EPDM	E
Air, water, oils, greases, solvents, acids, caustics	Fluoroelastomer - 20 to + 200°C	FKM	V

Application Limits

The limits for temperature, pressure and speed given in this catalogue cannot be fully exploited at the same time.

Furthermore, the lubrication properties, the media, the heat dissipation and the condition of the shaft surface affects the application limits.

The following p x v values can be used as general guidelines:

For shaft diameter from 30 mm to 170 mm:
 up to 3 (MPa x m/s) with good lubrication
 up to 1.5 (MPa x m/s) with poor lubrication
 up to 10 (MPa x m/s) with very good cooling

For smaller shaft diameters, the values must be reduced.



Design Instructions

Groove Design

Varilip® shaft seals in Table VII, pages 11-13, fit into grooves according to DIN 3760 or ISO 6194/1.

The recommendations defined in the standards apply to the grooves.

Shaft lead-in chamfer

During the installation of Varilip®, careful handling is necessary in order to avoid damaging the sealing lip. Depending on the design, several installation methods can be employed.

If the seal is mounted with its back to the shaft, the shaft ends must be rounded or lead-in chamfers must be provided (see figure 7).

When installing the seal on a shaft with the sealing lip against the end of the shaft, a lead-in chamfer is necessary (see Figure 6) whose smallest diameter is smaller than the diameter of the unstressed sealing lip. Table V contains guide values.

Table V Shaft lead-in chamfer

Shaft-\varnothing d_1	6 - 60	65 - 135	140 - 170
Cone-\varnothing d_3	$d_1 - 3$	$d_1 - 4$	$d_1 - 5.5$

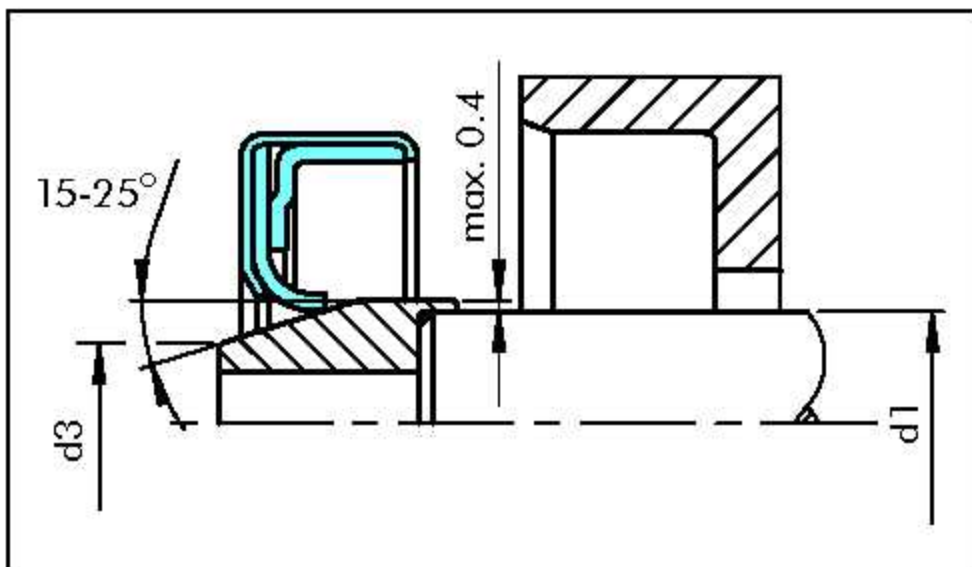

Figure 6 Fitting of the sealing lip with installation tool

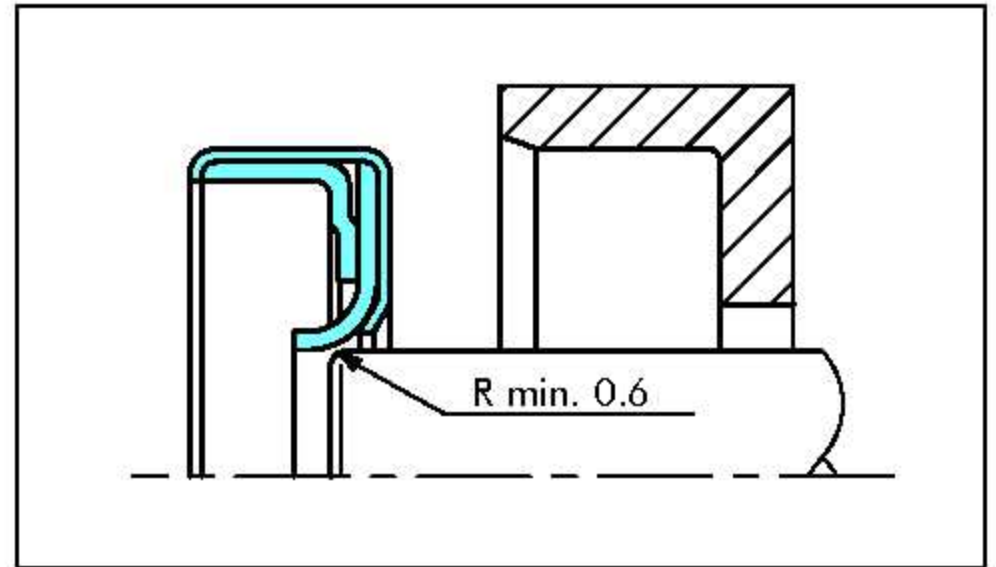

Figure 7 Fitting of the sealing lip with its back to the shaft

Shaft Surface Roughness

The functional reliability and service life of a seal depend to a very great extent on the quality and surface finish of the shaft surface to be sealed.

Scores, scratches, pores, concentric or spiral machining marks are not permitted. Ideally, dynamic shaft surfaces should be ground spiral-free.

The characteristics most frequently used to describe the surface microfinish R_a , R_z and R_{max} are defined in DIN 4762/ISO 4287/1 and DIN 4768. These characteristics alone, however, are not sufficient for assessing the suitability in seal engineering.

In addition, the material contact area M_r (previously percentage contact area t_p) in accordance with DIN 4762/ISO 4287/1 should be additionally demanded. The material contact area is determined in each case by the specific profile form. This in turn is directly dependent on the machining process employed.

In the Busak+Shamban recommendations, the surface finishes are defined as follows:

Table VI Surface roughness

	Surface roughness μm	
	Shaft surface	Housing bore
R_{max}	1.00 - 4.00	< 10.0
R_z	0.63 - 2.50	< 6.3
R_a	0.10 - 0.40	< 1.6

The material contact area M_r should be approx. 50 to 70%, determined at a cut depth $c = 0.25 \times R_z$, relative to a reference line c_{ref} , 5%.



Coaxiality Tolerance

In order to achieve a uniform radial load of the sealing lip on the surface of the shaft, the best possible coaxiality should exist between shaft and housing bore.

The maximum permissible coaxial deviation as a function of shaft diameter is shown in Figure 8.

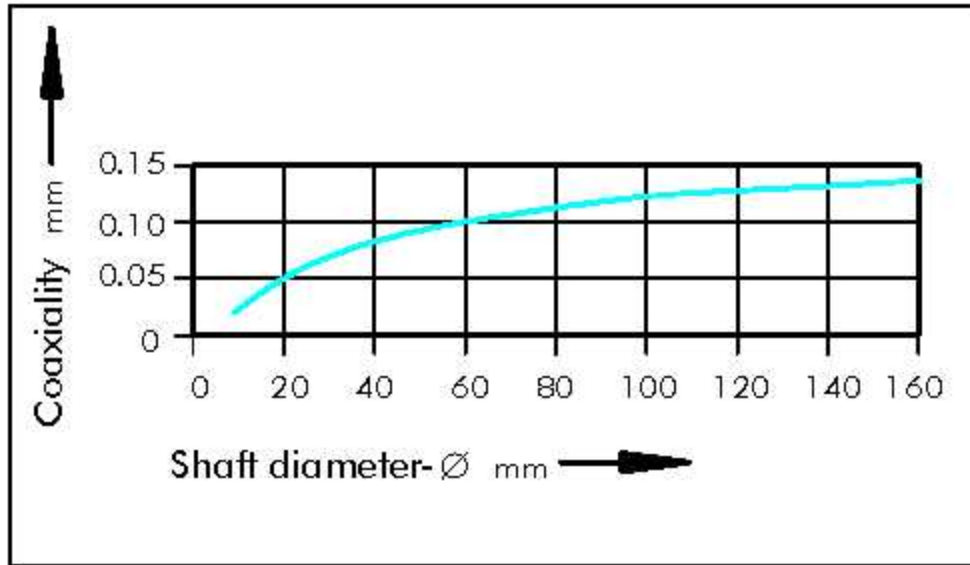

Figure 8 Coaxiality tolerance

Shaft runout Tolerance

In order to maintain the sealing function, the shaft eccentricity as a function of the speed must be limited as shown in Figure 9.

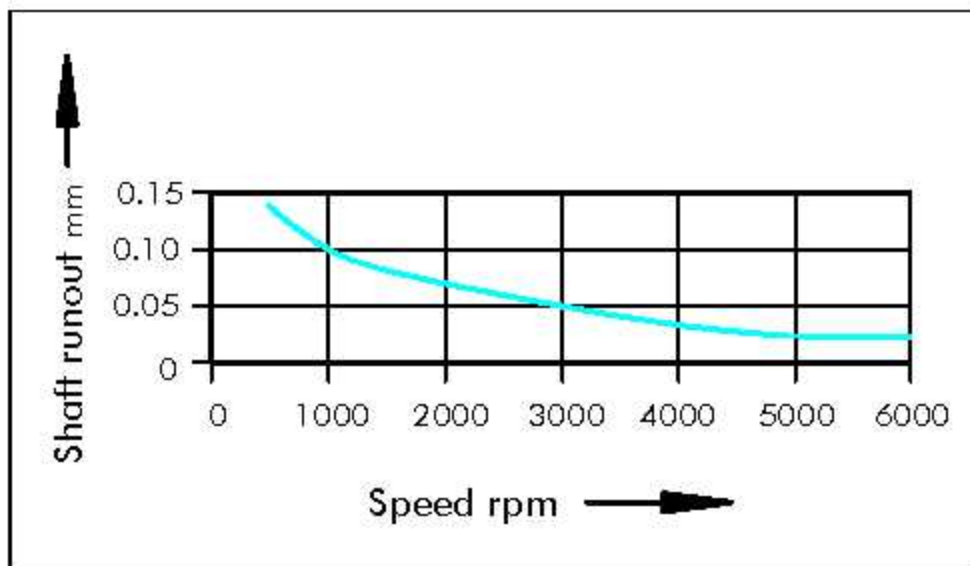

Figure 9 Max. shaft runout

Power consumption, dry running

Guide values for the frictional power consumption can be determined from the curve in Figure 10. It is plotted as a function of surface speed and operating pressure for a shaft diameter of 50 mm for a Varilip® type A and lip material T25.

Guide values for other shaft diameters can be calculated from the formula

$$p = p_{50} \times \left(\frac{d}{50 \text{ mm}}\right)^2 \text{ [W]}$$

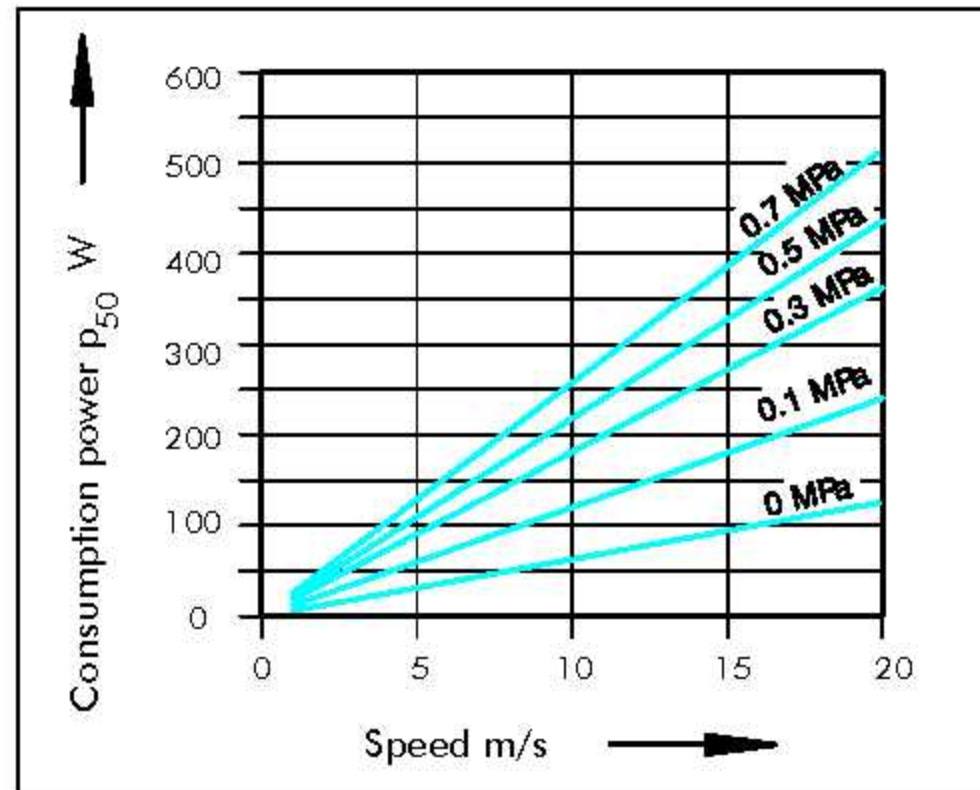

Figure 10 Power consumption on a 50 mm shaft-Ø

Torque

Figure 11 shows the torque as a function of the operating pressure for various Varilip® types and Turcon® materials for a shaft diameter of 50 mm. The torque for other shaft diameters can be roughly calculated from the formula

$$M = M_{50} \times \left(\frac{d}{50 \text{ mm}}\right)^2 \text{ [Nm]}$$

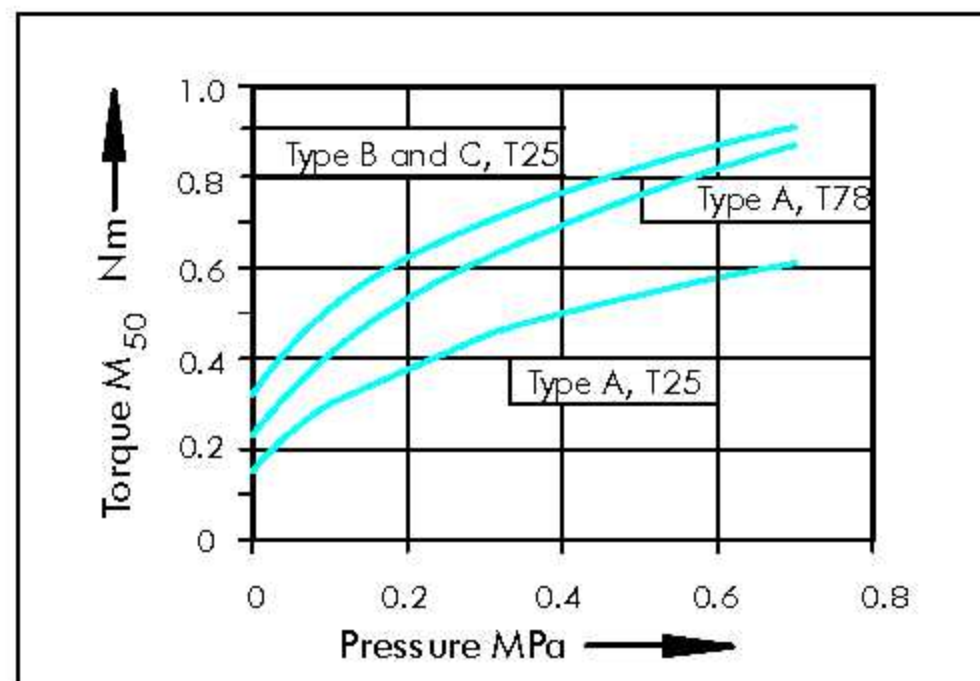

Figure 11 Torque on a 50 mm shaft-Ø



■ Installation Instructions

Preparation for Installation

The following points should be observed before installation of the seals:

- Check whether the shaft and the housing bore have an adequate lead-in chamfer
- Deburr and chamfer or round sharp edges, cover the tips of any screw threads
- Remove machining residues such as chips, dirt and other foreign particles and carefully clean all parts
- Use no sharp-edged installation tools
- Oil the seals before installation or use a suitable lubricant
- Only grease without solid additives (e.g. molybdenum disulphide or zinc sulphide additives) may be used for grease lubrication.

Installation in Housing

Varilip[®] shaft seals have a press fit in the housing. In order to avoid deformation of the seals, installation tools made e.g. of plastic such as that shown in Figure 12 should be used.

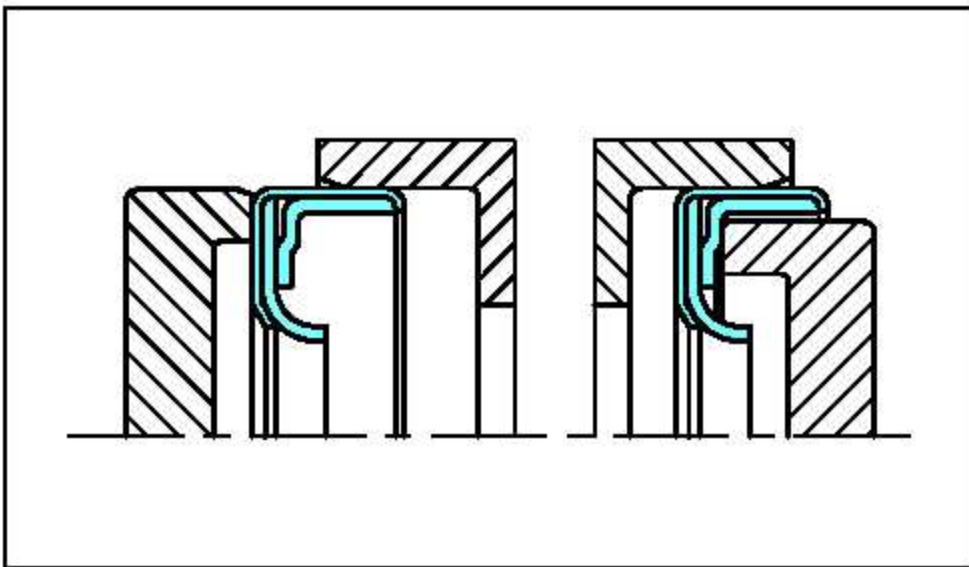

Figure 12 Installation using installation tools



Installation Recommendations

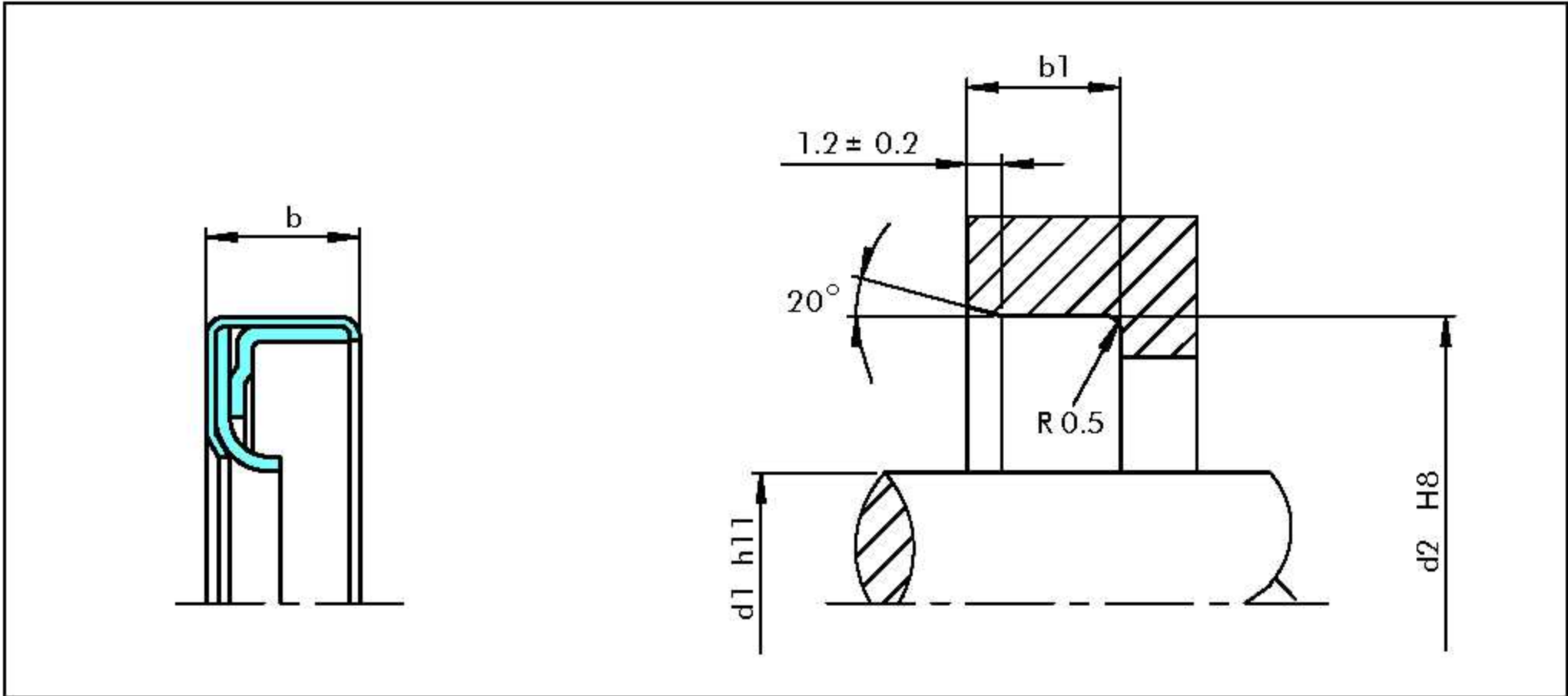

Figure 13 Installation drawing for pressure up to 0.2 MPa (2 bar)

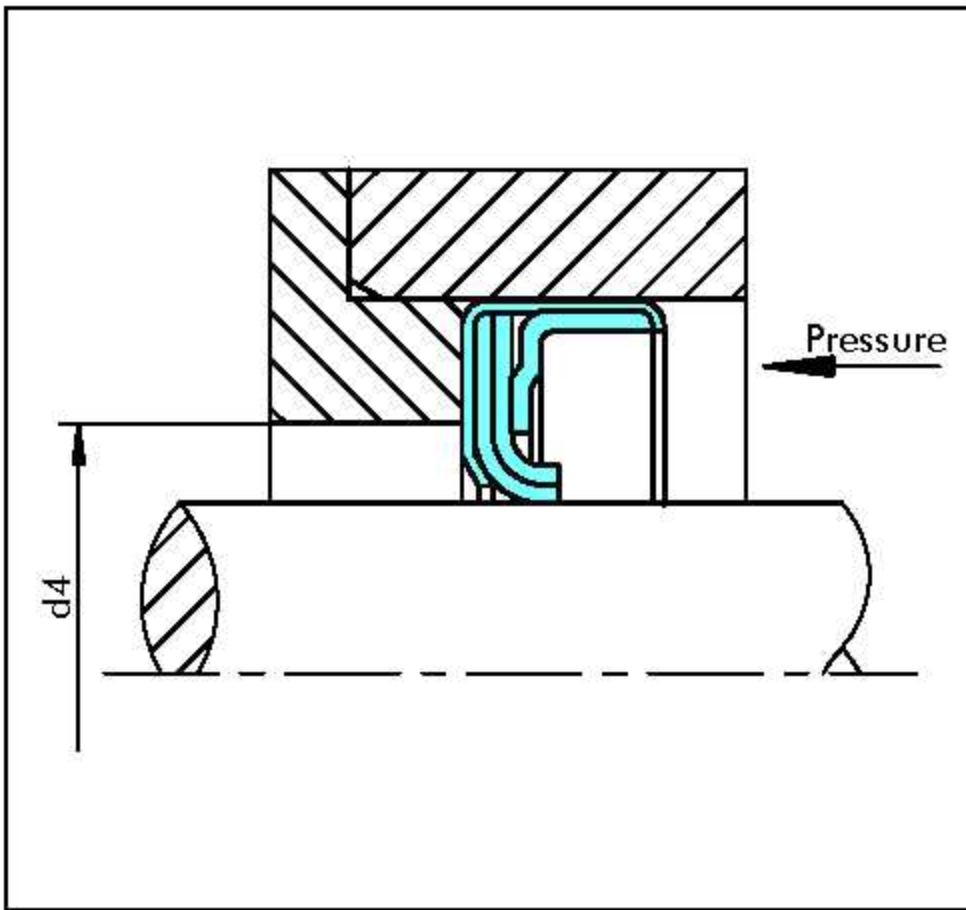

Figure 14 Installation for pressure from 0.2 MPa (2 bar) up to 2 MPa (20 bar)

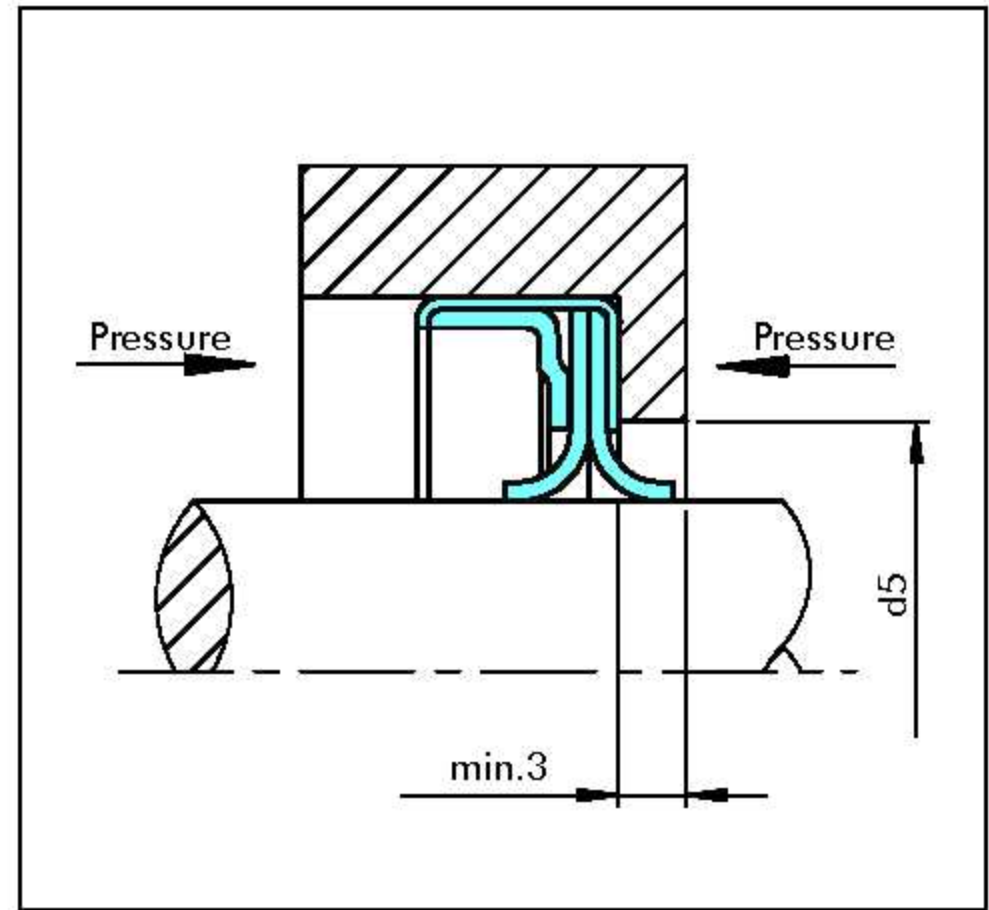

Figure 15 Installation type D

Table VII Preferred Series

d ₁	Sizes		Part No.	b _{1 min.}	d _{4 max.}	d _{5 min.}
	d ₂	b				
6	16	7	TP_100060	7.3	10	9.6
6	22	7	TP_200060	7.3	10	9.6
7	22	7	TP_100070	7.3	11	10.6
8	22	7	TP_100080	7.3	12	11.6
8	24	7	TP_200080	7.3	12	11.6
9	22	7	TP_100090	7.3	13	12.6
9	24	7	TP_200090	7.3	13	12.6
9	26	7	TP_300090	7.3	13	12.6
10	22	7	TP_100100	7.3	14	13.6
10	24	7	TP_200100	7.3	14	13.6
10	25	7	TP_300100	7.3	14	13.6
10	26	7	TP_400100	7.3	14	13.6
11	22	7	TP_100110	7.3	15	14.6
11	26	7	TP_200110	7.3	15	14.6
12	22	7	TP_100120	7.3	16	15.6
12	24	7	TP_200120	7.3	16	15.6
12	25	7	TP_300120	7.3	16	15.6
12	28	7	TP_400120	7.3	16	15.6
12	30	7	TP_500120	7.3	16	15.6
14	24	7	TP_100140	7.3	18	17.6
14	28	7	TP_200140	7.3	18	17.6
14	30	7	TP_300140	7.3	18	17.6
14	35	7	TP_400140	7.3	18	17.6
15	26	7	TP_100150	7.3	19	18.6
15	30	7	TP_200150	7.3	19	18.6
15	32	7	TP_300150	7.3	19	18.6
15	35	7	TP_400150	7.3	19	18.6
16	28	7	TP_100160	7.3	20	19.6
16	30	7	TP_200160	7.3	20	19.6
16	32	7	TP_300160	7.3	20	19.6
16	35	7	TP_400160	7.3	20	19.6
17	28	7	TP_100170	7.3	21	20.6
17	30	7	TP_200170	7.3	21	20.6
17	32	7	TP_300170	7.3	21	20.6
17	35	7	TP_400170	7.3	21	20.6
17	40	7	TP_500170	7.3	21	20.6
18	30	7	TP_100180	7.3	22	21.6
18	32	7	TP_200180	7.3	22	21.6
18	35	7	TP_300180	7.3	22	21.6
18	40	7	TP_400180	7.3	22	21.6



d ₁	Sizes		Part No.	b _{1 min.}	d _{4 max.}	d _{5 min.}
	d ₂	b				
20	30	7	TP_100200	7.3	24	23.6
20	32	7	TP_200200	7.3	24	23.6
20	35	7	TP_300200	7.3	24	23.6
20	40	7	TP_400200	7.3	24	23.6
20	47	7	TP_500200	7.3	24	23.6
22	32	7	TP_100220	7.3	26	25.6
22	35	7	TP_200220	7.3	26	25.6
22	40	7	TP_300220	7.3	26	25.6
22	47	7	TP_400220	7.3	26	25.6
24	35	7	TP_100240	7.3	28	27.6
24	37	7	TP_200240	7.3	28	27.6
24	40	7	TP_300240	7.3	28	27.6
24	47	7	TP_400240	7.3	28	27.6
25	35	7	TP_100250	7.3	29	28.6
25	40	7	TP_200250	7.3	29	28.6
25	42	7	TP_300250	7.3	29	28.6
25	47	7	TP_400250	7.3	29	28.6
25	52	7	TP_500250	7.3	29	28.6
26	37	7	TP_100260	7.3	30	29.6
26	42	7	TP_200260	7.3	30	29.6
26	47	7	TP_300260	7.3	30	29.6
28	40	7	TP_100280	7.3	32	31.6
28	47	7	TP_200280	7.3	32	31.6
28	52	7	TP_300280	7.3	32	31.6
30	40	7	TP_100300	7.3	34	33.6
30	42	7	TP_200300	7.3	34	33.6
30	47	7	TP_300300	7.3	34	33.6
30	52	7	TP_400300	7.3	34	33.6
30	62	7	TP_500300	7.3	34	33.6
32	45	7	TP_100320	7.3	36	35.6
32	45	8	TP_200320	8.3	36	35.6
32	47	7	TP_300320	7.3	36	35.6
32	47	8	TP_400320	8.3	36	35.6
32	52	7	TP_500320	7.3	36	35.6
32	52	8	TP_600320	8.3	36	35.6
35	47	7	TP_100350	7.3	39	38.6
35	50	7	TP_200350	7.3	39	38.6
35	50	8	TP_300350	8.3	39	38.6
35	52	7	TP_400350	7.3	39	38.6
35	52	8	TP_500350	8.3	39	38.6
35	55	8	TP_600350	8.3	39	38.6
35	62	7	TP_700350	7.3	39	38.6



d ₁	Sizes		Part No.	b ₁ min.	d ₄ max.	d ₅ min.
	d ₂	b				
36	47	7	TP_100360	7.3	40	39.6
36	50	7	TP_200360	7.3	40	39.6
36	52	7	TP_300360	7.3	40	39.6
36	62	7	TP_400360	7.3	40	39.6
38	52	7	TP_100380	7.3	42	41.6
38	55	7	TP_200380	7.3	42	41.6
38	55	8	TP_300380	8.3	42	41.6
38	58	8	TP_400380	8.3	42	41.6
38	62	7	TP_500380	7.3	42	41.6
38	62	8	TP_600380	8.3	42	41.6
40	52	7	TP_100400	7.3	44	43.6
40	55	7	TP_200400	7.3	44	43.6
40	55	8	TP_300400	8.3	44	43.6
40	62	7	TP_400400	7.3	44	43.6
40	62	8	TP_500400	8.3	44	43.6
40	72	7	TP_600400	7.3	44	43.6
42	55	8	TP_100420	8.3	46	45.6
42	62	8	TP_200420	8.3	46	45.6
42	72	8	TP_300420	8.3	46	45.6
45	60	8	TP_100450	8.3	49	48.6
45	62	8	TP_200450	8.3	49	48.6
45	65	8	TP_300450	8.3	49	48.6
45	72	8	TP_400450	8.3	49	48.6
48	62	8	TP_100480	8.3	52	51.6
48	72	8	TP_200480	8.3	52	51.6
50	65	8	TP_100500	8.3	54	53.6
50	68	8	TP_200500	8.3	54	53.6
50	72	8	TP_300500	8.3	54	53.6
50	80	8	TP_400500	8.3	54	53.6
52	68	8	TP_100520	8.3	56	55.6
52	72	8	TP_200520	8.3	56	55.6
55	70	8	TP_100550	8.3	59	58.6
55	72	8	TP_200550	8.3	59	58.6
55	80	8	TP_300550	8.3	59	58.6
55	85	8	TP_400550	8.3	59	58.6
56	70	8	TP_100560	8.3	60	59.6
56	72	8	TP_200560	8.3	60	59.6
56	80	8	TP_300560	8.3	60	59.6
56	85	8	TP_400560	8.3	60	59.6
58	72	8	TP_100580	8.3	62	61.6
58	80	8	TP_200580	8.3	62	61.6



d ₁	Sizes		Part No.	b _{1 min.}	d _{4 max.}	d _{5 min.}
	d ₂	b				
60	75	8	TP_100600	8.3	64	63.6
60	80	8	TP_200600	8.3	64	63.6
60	85	8	TP_300600	8.3	64	63.6
60	90	8	TP_400600	8.3	64	63.6
62	85	10	TP_100620	10.3	68	66.4
62	90	10	TP_200620	10.3	68	66.4
63	85	10	TP_100630	10.3	69	67.4
63	90	10	TP_200630	10.3	69	67.4
65	85	10	TP_100650	10.3	71	69.4
65	90	10	TP_200650	10.3	71	69.4
65	100	10	TP_300650	10.3	71	69.4
68	90	10	TP_100680	10.3	74	72.4
68	100	10	TP_200680	10.3	74	72.4
70	90	10	TP_100700	10.3	76	74.4
70	95	10	TP_200700	10.3	76	74.4
70	100	10	TP_300700	10.3	76	74.4
72	95	10	TP_100720	10.3	78	76.4
72	100	10	TP_200720	10.3	78	76.4
75	95	10	TP_100750	10.3	81	79.4
75	100	10	TP_200750	10.3	81	79.4
78	100	10	TP_100780	10.3	84	82.4
80	100	10	TP_100800	10.3	86	84.4
80	110	10	TP_200800	10.3	86	84.4
85	110	12	TP_100850	12.4	91	89.4
85	120	12	TP_200850	12.4	91	89.4
90	110	12	TP_100900	12.4	96	94.4
90	120	12	TP_200900	12.4	96	94.4
95	120	12	TP_100950	12.4	101	99.4
95	125	12	TP_200950	12.4	101	99.4
100	120	12	TP_101000	12.4	106	104.4
100	125	12	TP_201000	12.4	106	104.4
100	130	12	TP_301000	12.4	106	104.4
105	130	12	TP_101050	12.4	111	109.4
105	140	12	TP_201050	12.4	111	109.4
110	130	12	TP_101100	12.4	116	114.4
110	140	12	TP_201100	12.4	116	114.4
115	140	12	TP_101150	12.4	121	119.4
115	150	12	TP_201150	12.4	121	119.4
120	150	12	TP_101200	12.4	126	124.4
120	160	12	TP_201200	12.4	126	124.4
125	150	12	TP_101250	12.4	131	129.4
125	160	12	TP_201250	12.4	131	129.4



Sizes			Part No.	b ₁ min.	d ₄ max.	d ₅ min.
d ₁	d ₂	b				
130	160	12	TP_101300	12.4	136	134.4
130	170	12	TP_201300	12.4	136	134.4
135	170	12	TP_101350	12.4	141	139.4
140	170	15	TP_101400	15.4	148	147.0
145	175	15	TP_101450	15.4	153	152.0
150	180	15	TP_101500	15.4	158	157.0
160	190	15	TP_101600	15.4	168	167.0
170	200	15	TP_101700	15.4	178	177.0

The sizes printed in bold type should be preferred.

Other sizes are available on request.

Ordering Example

Varilip®, Type A

Shaft diameter d₁ = 30 mm

Outside diameter d₂ = 47 mm

Width b = 7 mm

Table VII: Part No. TP_300300

The material is selected from Tables II to IV, page 6.

The type is inserted as the 3rd digit.

Order-No.	TP	A	3	0	0300	-	T25	1	V
Type + cross sec.									
Type (Standard)									
Shaft-∅ x 10									
Quality Index (Standard)									
Material code - sealing lip									
Material code - casing									
Material code - gasket									

For other types by analogy:

Order No.: TP **B** 300300 - T 25 1V

TP **C** 300300 - T 25 1V

TP **D** 300300 - T 25 1V